

DO NOT SCALE DRAWING DIMENSION IN METRIC

PROJECT NO.

SIMILAR ITEM

DWG. NO. SD-35728-001

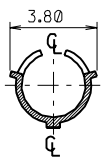
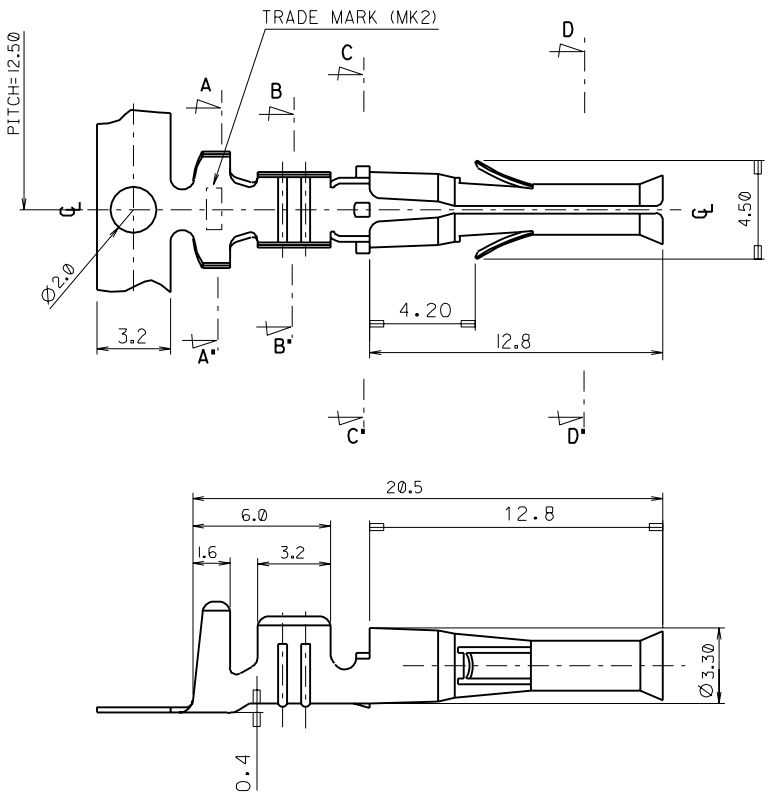

SECTION:C-C*

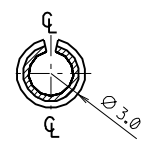

SECTION:D-D*

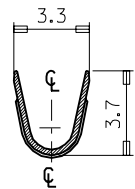

SECTION:B-B*

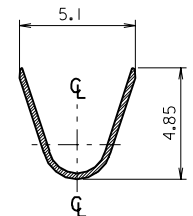

SECTION:A-A*

NOTES

1. MATERIAL: BRASS THICKNESS:0.25
2. FINISH: PRE-TIN PLATING
6. APPLICABLE HOUSING:Ø2.0 PLUG HOUSING (35143-**-01, 35144-0401) • MEANS CIRCUIT NO.
7. MATING TERMINAL:Ø2.0 PIN TERMINAL (35727-0201)
8. APPLICABLE WIRE RANGE: AWG #20-#14, INSUL.DIA 1.9-3.4mm

MATERIAL NO.	ENG. NO.
357280201	35728-0201

REVISED	EC NO. KOR 1999-0120	CHK: W.Y.YANG 99.12.31	APPR:
DESCRIPTION	MAJOR = 3	CRITICAL = 0	REV
	C		

QUALITY SYMBOLS	DESCRIPTION
MAJOR = 3	
CRITICAL = 0	

GENERAL TOLERANCES: (UNLESS SPECIFIED)	
	mm INCH
4 PLACES	±0.25 ±
3 PLACES	±0.25 ±
2 PLACES	±0.25 ±
1 PLACE	±0.25 ±
ANGULAR: ± 3°	
DRAFT WHERE APPLICABLE MUST REMAIN WITHIN DIMENSIONS	

SCALE 5:1	DESIGN UNITS <input checked="" type="checkbox"/> mm <input type="checkbox"/> INCH
DRAWN BY & DATE W.Y.YANG 92/03/04	
CHECKED BY & DATE B.K.CHOI 92/03/04	
APPROVED BY & DATE C.W.LEE 92/03/04	
CAD FILENAME E7280201.DGN	

DIMENSIONS: <input type="checkbox"/> mm <input type="checkbox"/> INCH <input checked="" type="checkbox"/> mm ONLY		SHT	REV
THIRD ANGLE PROJECTION		REVISE ON CAD ONLY	
TITLE: 2.0 DIA SOCKET TERMINAL			
MOLEX INCORPORATED KOREA			
MATERIAL NO. SEE CHART	DRAWING NO. SD-35728-001	SHEET NO. 10F1	SIZE B
THIS DRAWING CONTAINS INFORMATION THAT IS PROPRIETARY TO MOLEX INCORPORATED AND SHOULD NOT BE USED WITHOUT WRITTEN PERMISSION.			