

24-Bit, 1.8V to 3.3V Bi-Directional Level Shifting Transceiver
Product Features

- PI74HSTL1212 is designed for translation between 1.8V HSTL and LVC MOS
- Supports 1.8V HSTL Class I Buffer
- Industrial operation at -40°C to $+85^{\circ}\text{C}$
- Dual Independent 12-Bit Slice Direction Control
- Packaging (Pb-free & Green available):
– 64-pin 240-mil wide TSSOP (A)

Product Description

Pericom Semiconductor's PI74HSTL1212 consists of two 12-Bit bi-directional non-inverting transceivers with two separate supply rails, A-Port (V_{CCA}) set at 1.8V, and B-Port (V_{CCB}) set at 3.3V. Each set of 12 transceivers allows translation from a 1.8V to 3.3V and back again. The control inputs 1DAB/ $\overline{1DBA}$ and 2DAB/ $\overline{2DBA}$ allows independent 12-Bit slice direction control for greater flexibility.

The PI74HSTL1212 is particularly useful for asynchronous communications between HSTL and LV TTL/LVC MOS data buses.

Truth Table (Each 12-bit slice)

Inputs	Operation
XDAB / \overline{XDBA}	
H (TTL)	XA to XB HSTL to LV TTL (LVC MOS)
L (TTL)	XB to XA, LV TTL (LVC MOS) to HSTL

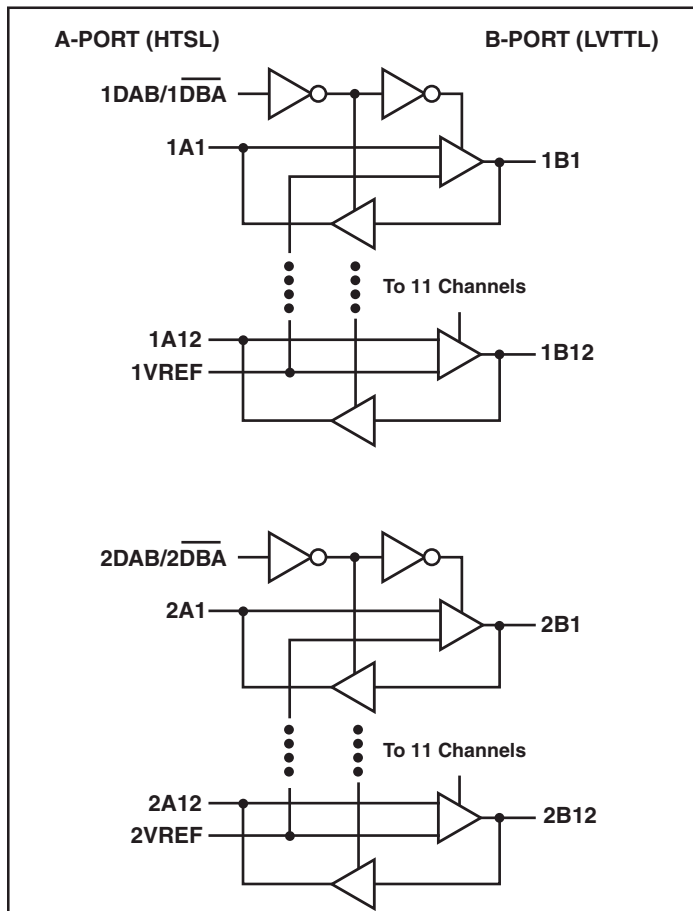
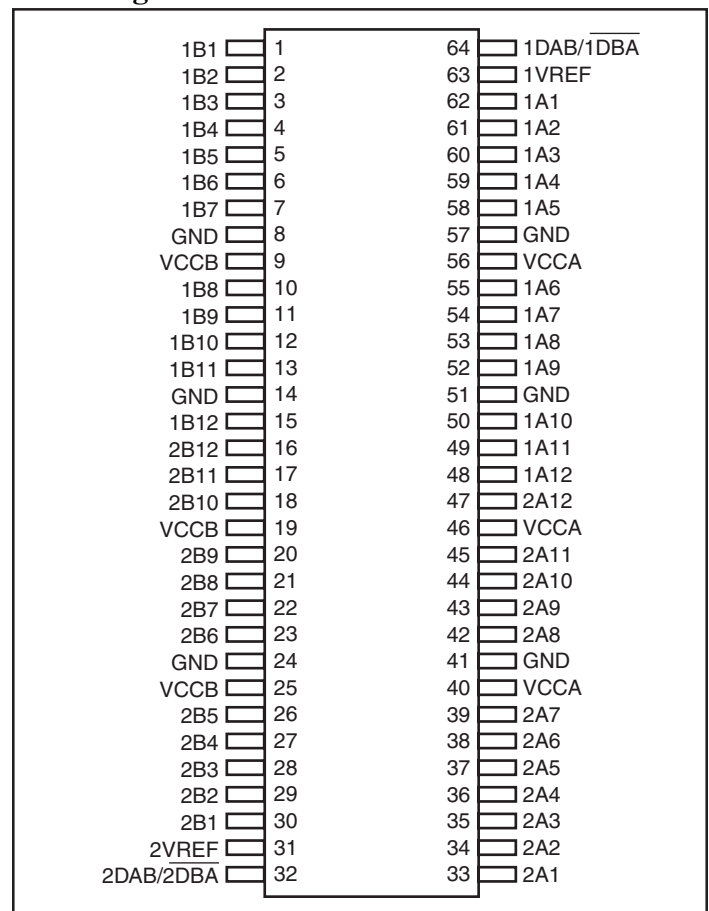
Logic Block Diagram

Pin Configuration

Maximum Ratings

(Absolute maximum ratings over operating free-air temperature range from V_{CCB} at 3.3V & V_{CCA} at 1.5 - 2.5V (unless otherwise noted))

Supply voltage range:	V_{CCA}	-0.5V to 3.6V
	V_{CCB}	-0.5V to 3.6V
Input Voltage Range, V_I	Except I/O ports ⁽¹⁾	-0.5V to 3.6V
	I/O port A ⁽²⁾	-0.5V to $V_{CCA}+0.1V$
	I/O port B ⁽¹⁾	-0.5V to $V_{CCB}+0.1V$
Input clamp current, I_{IK} ($V_I < 0$)		-25mA
Output clamp current, I_{OK} ($V_O < 0$)		-25mA
Continuous output current, I_O		$\pm 25mA$
Continuous current through each V_{CC} or GND		$\pm 50mA$
Package thermal impedance, θ_{JA} ⁽³⁾ : A package		55°C/W
Storage temperature range, T_{STG}		-65°C to 150°C

Notes:

Stresses greater than those listed under MAXIMUM RATINGS may cause permanent damage to the device. This is a stress rating only and functional operation of the device at these or any other conditions above those indicated in the operational sections of this specification is not implied. Exposure to absolute maximum rating conditions for extended periods may affect reliability.

1. This value is limited to 3.6V maximum.
2. This value is limited to 2.7V maximum.
3. The package thermal impedance is calculated in accordance with JESD 51.

Recommended Operating Conditions for V_{CCB} at 3.3V⁽¹⁾

		Min.	Max.	Units
V_{CCB}	Supply voltage	3.0	3.6	V
V_{IH}	High-level voltage	2		
V_{IL}	Low-level voltage		0.8	
V_{IA}	Input Voltage	0	V_{CCB}	
V_{OB}	Output Voltage	0	V_{CCB}	
I_{OH}	High-level output current		-12	mA
I_{OL}	Low-level output current		12	
T_A	Operating free-air temperature	-40	85	°C

Recommended Operating Conditions for V_{CCA} at 1.8V⁽¹⁾

		Min.	Nom.	Max.	Units	
V_{CCA}	Supply Voltage	1.7	1.8	1.9	V	
V_{REF}	Reference Voltage	0.85	0.9	0.95	V	
V_{IN}	Input Voltage	0		1.9	V	
V_{IH}	AC High-Level Input Voltage	All Inputs	$V_{REF} + 200mV$		V	
V_{IL}	AC Low-Level Input Voltage			$V_{REF} - 200mV$	V	
V_{IH}	DC High-Level Input Voltage		$V_{REF} + 100mV$		$V_{CCA} + 300mV$	V
V_{IL}	DC Low-Level Input Voltage		-500mV		$V_{REF} - 100mV$	V
I_{OH}	High-Level Output Current			-8	mA	
I_{OL}	Low-Level Output Current			8	mA	
T_A	Operating Free-Air Temperature	-40		85	°C	

Notes:

1. To ensure proper device operation, all unused device inputs must be held at the associated V_{CC} or GND.

Electrical Characteristics, V_{CCA}

Over recommended operating free-air temperature range for V_{CCA} = 1.8V ±100mV

Parameters		Test Conditions	V _{CCA}	Min.	Typ. ⁽¹⁾	Max.	Units
V _{OH}		I _{OH} = -8mA	1.7	V _{CCA} -0.4			V
V _{OL}		I _{OH} = 8mA	1.7			0.4	
I _{DD}		V _{IN} = 0 or V _{CCA}	1.9			TBD	
I _I	Data Inputs	V _{IN} = 0 or V _{CCA}	1.9			±5	μA
	V _{REF}	V _{REF} = 0.95V	1.9			90	
C _O	Outputs	V _O = 0	0		6.0		pF

Notes:

1. Typical values at V_{CCA} 1.8V and T_A = 25°C

Electrical Characteristics, V_{CCB}

Over recommended operating free-air temperature range for V_{CCB} = 3.3V ±300mV

Parameters		Test Conditions	V _{CCB}	Min.	Typ. ⁽¹⁾	Max.	Units
V _{IK}		I _I = -18mA	3.0			-1.2	V
V _{OH}		I _{OH} = -12mA	3.0	2.4			
V _{OL}		I _{OH} = 12mA	3.0			0.5	
I _{DD}		V _{IN} = 0 or V _{CCB}	3.6			TBD	
I _I	Control Inputs	V _{IN} = 0 or V _{CCB}	3.6			±5	μA
	Data Inputs	V _{IN} = 0 or V _{CCB}	3.6			±5	
C _I	Control Inputs	V _{IN} = 0 or 3.3V	3.3		4.4		pF
C _O	Outputs	V _O = 0	0		6.0		

Notes:

1. Typical values at V_{CCB} 3.3V and T_A = 25°C

Switching Characteristics

Over recommended operating free-air temperature range (see Figures 1, 2, & 3)

Parameter	From (Input)	To (Output)	V _{CCA} = 1.8V ± 0.1V		V _{CCB} = 3.3V ± 0.3V		Units
			Min.	Max.	Max.	Min.	
t _{PD}	A	B	1.0		3.0		ns
	B	A	1.0		3.0		
t _{sk(o)} ⁽¹⁾					0.35		

Notes:

1. This is the skew between any two outputs in the same 12-bit bank of the same package switching in any direction on the same port. This is guaranteed by design, this is not a production test.

Parameter Measurement Information - B to A Direction

$V_{CCB} = 3.3V \pm 0.3V$ and $V_{CCA} = 1.8V \pm 0.10V$

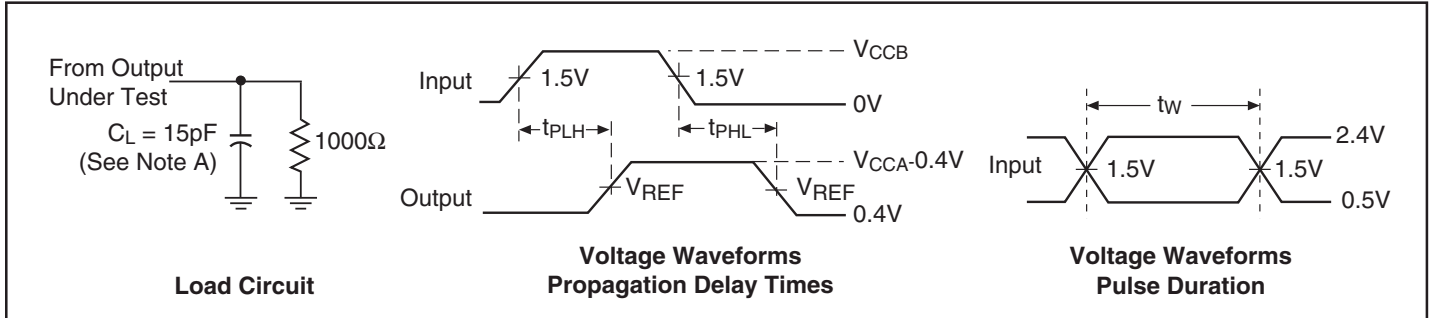

Figure 1. Load Circuit and Voltage Waveforms

Parameter Measurement Information - A to B Direction

$V_{CCA} = 1.8V \pm 0.10V$ and $V_{CCB} = 3.3V \pm 0.3V$

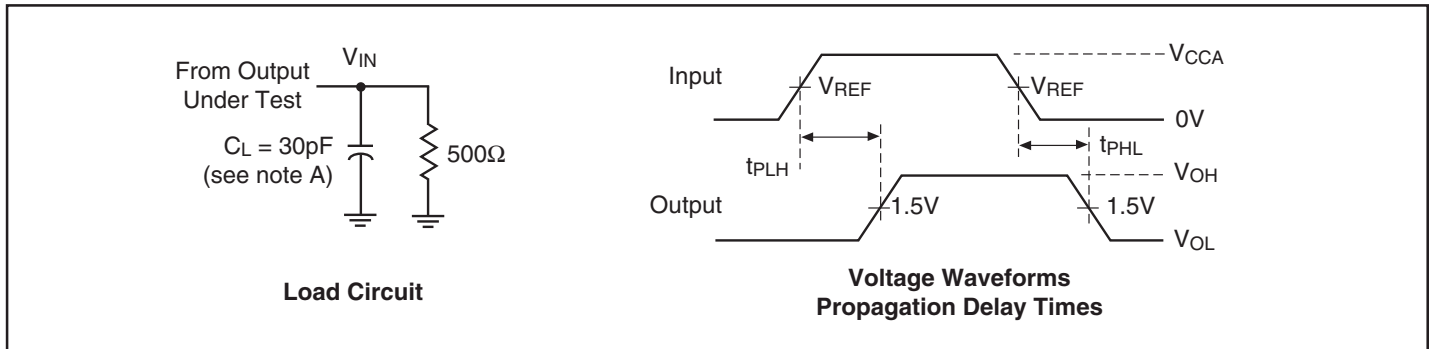

Figure 2. Load Circuit and Voltage Waveforms

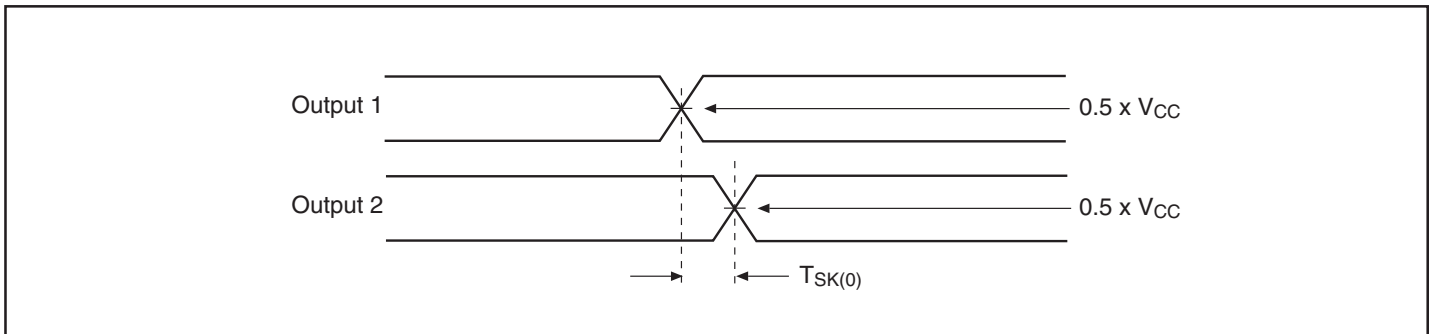
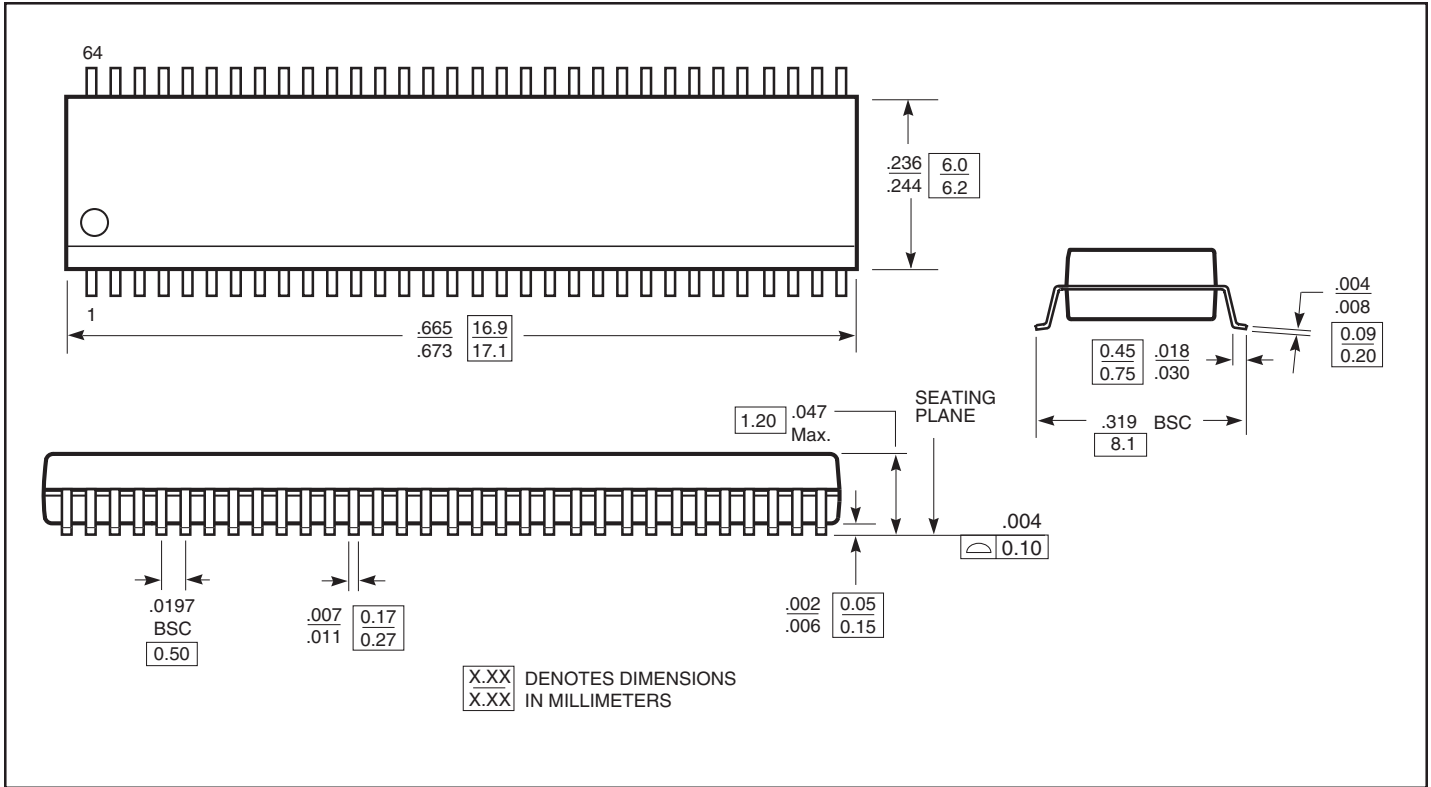

Figure 3. Opposite Edge Skew

Notes:

- A. C_L includes probe and jig capacitance.
- Waveform 1 is for an output with internal conditions such that the output is low except when disabled by the output control. Waveform 2 is for an output with internal conditions such that the output is high except when disabled by the output control.
- All input pulses are supplied by generators having the following characteristics: $PRR \leq 10Mz$, $Z_O = 50\text{-ohm}$, $t_r \leq 2.5ns$, $t_f \leq 2.5ns$.
- The outputs are measured one at a time with one transition per measurement.
- t_{PLZ} and t_{PHZ} are the same as t_{DIS} .
- t_{PZL} and t_{PZH} are the same as t_{EN} .
- t_{PLH} and t_{PHL} are the same as t_{PD} .

Packaging Mechanical: 64-pin TSSOP (A)



Ordering Information

Ordering Code	Package Type	Package Description
PI74HSTL1212A	A	64-pin, 240 mil wide plastic TSSOP
PI74HSTL1212AE	A	Pb-free & Green, 64-pin, 240 mil wide plastic TSSOP

Notes:

- Thermal characteristics can be found on the company web site at www.pericom.com/packaging/
- E = Pb-free & Green
- Adding an X suffix = Tape/Reel