

# SMART Position Sensor, Rotary Configuration

## Superior Measurement. Accurate. Reliable. Thinking.



### DESCRIPTION

Honeywell's SMART Position Sensors are some of the most durable, adaptable, and lightweight absolute position sensors available in the industry, enabling highly accurate motion control and improving operation efficiency and safety.

Why is the SMART Position Sensor smart? SMART means that this is a sensor that can essentially think for itself. With the SMART position technology, Honeywell has utilized MR (magneto-resistive) technology through the ASIC (Application-Specific Integrated Circuit) at a level never before accomplished. The rotary configuration joins Honeywell's SMART Position Sensor family of proven linear and arc configurations.

The SMART Position Sensor, Rotary Configuration, is a non-contacting sensing solution for absolute position sensing with enhanced accuracy. It senses the position of a magnet relative to the sensor in a range of 0° to 360°.

Honeywell uses a patented combination of an ASIC and an array of MR sensors to accurately and reliably determine the position of a magnet collar attached to a rotating object so that the object's position can be determined or controlled. The output and the MR sensor sequence determine the nearest pair of MR sensors to the center of the magnet location. The output of these two MR sensors is then used to determine the position of the magnet between them.

The SMART Position Sensor, Rotary Configuration, fits on a 25,4 mm [1 in] shaft. A mounting tool fixture (purchased separately) provides repeatable installation.

### VALUE PROPOSITIONS (★ = competitive differentiator)

- ★ **Non-contact design:** Eliminates mechanical failure mechanisms, reducing wear, which improves reliability and durability, and minimizes downtime
- ★ **Combined patented MR sensor and ASIC technology provides absolute position sensing:**
  - Helps OEMs reduce warranty costs because they don't have to replace worn or broken component parts
  - Helps end-users reduce downtime due to fewer calibration requirements
- ★ **No internal moving parts:** Automotive-grade potting makes the sensor more resistant to vibration, shock, and extreme temperatures, improving reliability
- ★ **Repeatable output:** Occurs within a 3,0 mm ±2,0 mm [0.118 in ±0.079 in] air gap between the sensor and magnet collar, expanding application opportunities
- **High accuracy:** Measures values down to 0.01°; better sensor accuracy can provide better system accuracy in the application
- ★ **IP67 and IP69K sealing:** Allows for use in harsh environments such as dust, immersion up to 1 m [39.37 in] of water for 30 minutes, and high pressure water sprays
- ★ **High shock and vibration resistance:** Allows for use in a wide variety of tough applications

### FEATURES AND BENEFITS

- **Minimal signal error:** Exists up to 2,50 mm [0.10 in] of radial error, simplifying design-in
- **RoHS-compliant:** Materials meet Directive 2002/95/EC

# SMART Position Sensor

## POTENTIAL APPLICATIONS

### Transportation:

- Steering angle
- Articulation angle
- Boom arm detection

### Industrial:

- Solar panels
- Wind turbines

**Table 1. Specifications<sup>1</sup>**

Characteristic	Component	Parameter	Note
Sensing range	sensor only	360°	–
Resolution		0.01°	–
Supply voltage		12 Vdc to 30 Vdc	–
Output		4 mA to 20 mA	–
Supply current		90 mA max.	–
Linearity: 25 °C [77 °F] TC: >85 °C [158 °F]		-0.03 %FS min., 0.030 %FS max. 0.0011 %FS/°C	2, 4, 7
Offset: 25 °C [77 °F] TC: >85 °C [158 °F]		-0.044 %FS min., -0.011 %FS typ., 0.022 %FS max. 0.0033 %FS/°C	3, 4, 5, 7
Accuracy		-0.069 %FS min., 0.069 %FS max.	4
Sensitivity: 25 °C [77 °F] TC: >85 °C [158 °F]		44.43 µA/° min., 44.43 µA/° typ., 44.48 µA/° max. 80 ppm/°C	6, 7
Reverse polarity		-12 Vdc to -30 Vdc	–
Initial startup time		130 ms typ.	–
Termination		M12 connector, male 5 pin	–
Operating temperature		sensor and magnet collar	-40 °C to 85 °C [-40 °F to 185 °F]
Storage temperature	-40 °C to 150 °C [-40 °F to 302 °F]		–
Air gap	3,0 mm ±2,0 mm [0.118 in ±0.079 in] typ.		–
Sealing	IP67, IP69K		–
Shock	50 G half sine wave with 11 ms duration		–
Vibration	20 G from 10 Hz to 2000 Hz		–
Housing material	aluminum with powder coating		–
Approvals	CE		–
Mounting: screws recommended torque	M5 or UNC 10-24 5 N m to 7 N m [44.25 in lb to 61.95 in lb]		–
Material	magnet only		neodymium (sintered NdFeB)
Strength	only	3700 Gauss	–

### Notes:

1. Specifications are based on a non-ferrous shaft.
2. Linearity: Deviations from a best fit straight line through the output, expressed as a percentage of the full scale signal range (% of 16 mA).
3. Accuracy: Deviations from the ideal output line expressed as a percentage of the full scale signal range (% of 16 mA).
4. %FS: Error expressed as a percentage of the output span of the sensor (% of 16 mA).
5. Offset: Deviation from the ideal output at the minimum input condition, expressed as a percentage of the full scale signal range (% of 16 mA).
6. Sensitivity: The slope of the output signal vs magnet travel, expressed as µA of output per degree of travel.
7. TC: Temperature coefficient of a given parameter, as a percentage of the full scale signal range (% of 16 mA) per degree of temperature rise from 25 °C [77 °F].

# Rotary Configuration

**Table 2. % Linearity**

		Radial Error (mm)									
		0	0.05	0.1	0.25	0.5	0.75	1	1.5	2	2.5
Air Gap Error (mm)	-2	-0.005	0.001	0.007	0.027	0.066	0.113	0.166	0.294	0.450	0.635
	-1	-0.002	0.003	0.008	0.025	0.060	0.101	0.150	0.269	0.417	0.593
	0	0.000	0.004	0.008	0.023	0.053	0.090	0.135	0.245	0.383	0.550
	1	0.002	0.005	0.009	0.021	0.047	0.079	0.119	0.220	0.350	0.508
	2	0.005	0.007	0.009	0.019	0.040	0.068	0.104	0.196	0.317	0.466
	3	0.007	0.008	0.010	0.017	0.033	0.057	0.088	0.172	0.284	0.424

**Table 3. % Accuracy**

		Radial Error (mm)									
		0	0.05	0.1	0.25	0.5	0.75	1	1.5	2	2.5
Air Gap Error (mm)	-2	0	0.006	0.012	0.033	0.076	0.129	0.191	0.263	0.538	0.770
	-1	0	0.005	0.011	0.029	0.069	0.118	0.176	0.245	0.509	0.733
	0	0	0.004	0.009	0.026	0.061	0.106	0.162	0.226	0.479	0.697
	1	0	0.004	0.008	0.022	0.054	0.095	0.147	0.208	0.450	0.660
	2	0	0.003	0.006	0.018	0.047	0.084	0.132	0.190	0.420	0.623
	3	0	0.002	0.005	0.015	0.039	0.073	0.117	0.171	0.391	0.586

**Figure 1. Sensor**

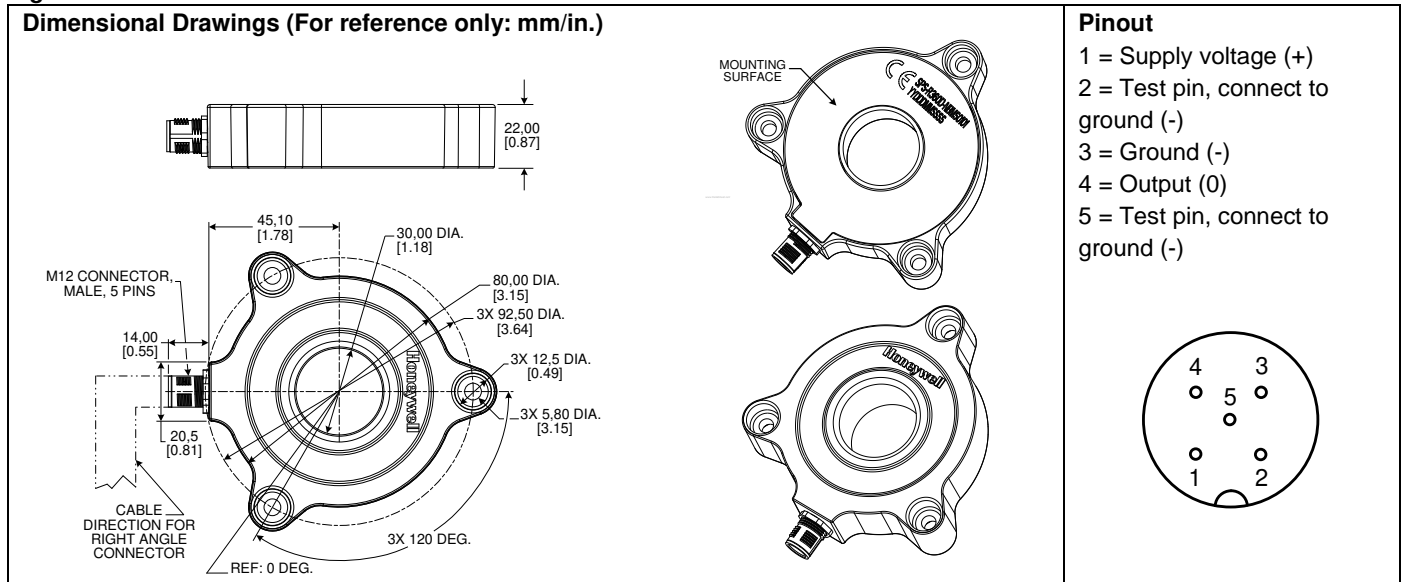

**Figure 2. Magnet Collar**

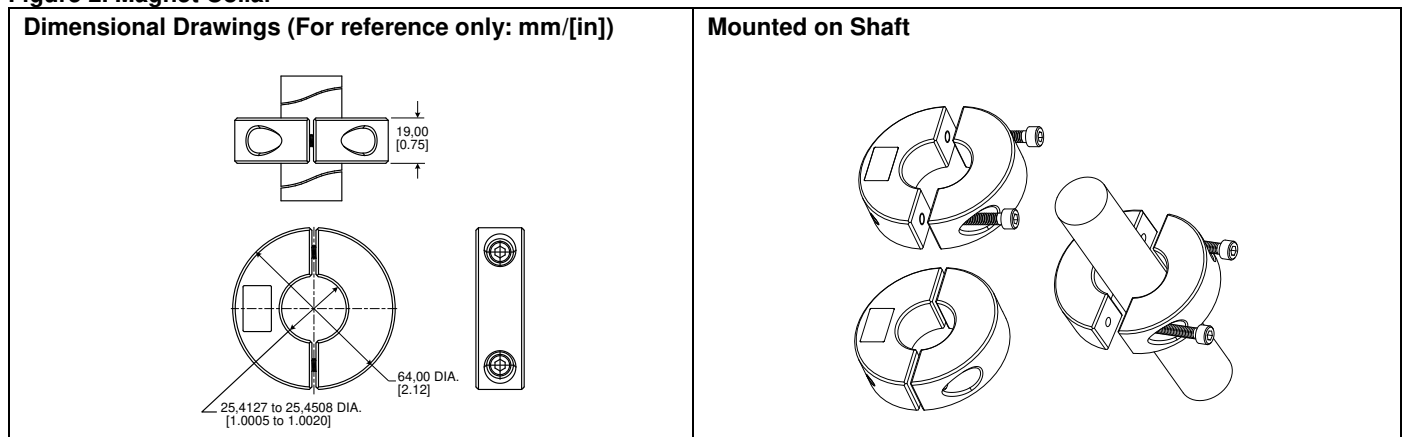

# SMART Position Sensor

## NOTICE

Stationary ferrous material often creates an initial offset upon installation. If the stationary ferrous material never moves in relation to the sensor after the installation, and the environment remains ferrous-free, performance should be repeatable. Ensure the sensor is tested in the application.

Figure 3. Assembly Tools

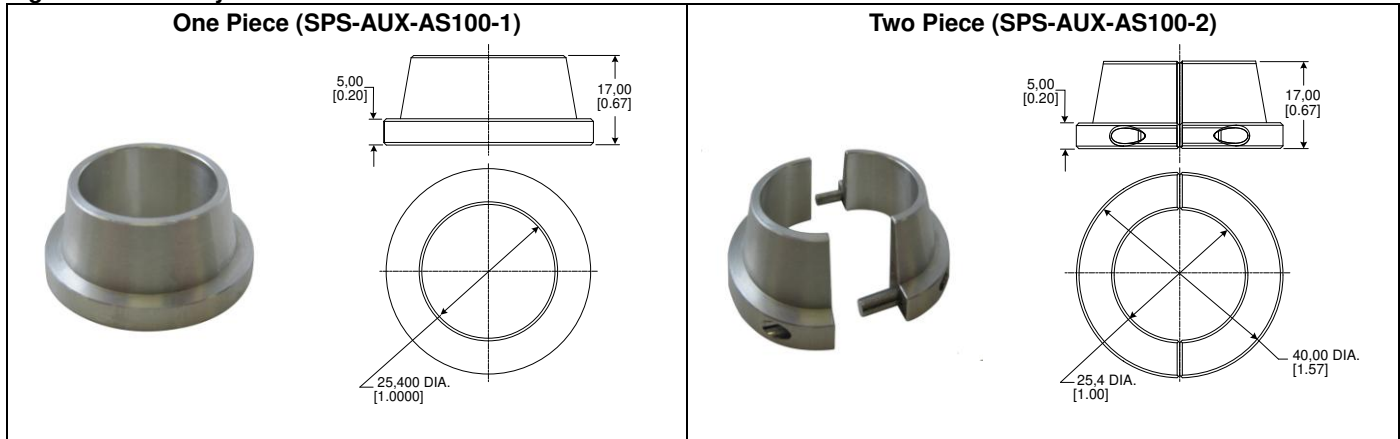

## NOTICE

### ASSEMBLY TOOL USE

Honeywell recommends using an assembly tool to help align the magnetic axis of rotation to the inside diameter of the Sensor.

### Assembly Tool Use

1. Place the sensor over the shaft with its epoxy side facing the mating surface of the mounting plate.
2. Loosely assemble the mounting screws in the sensor.
3. Install the assembly tool on the shaft.
4. Push the assembly tool into the rotary sensor to center on the shaft.
5. Tighten the sensor mounting screws while maintaining pressure on the assembly tool.
6. Remove the assembly tool.

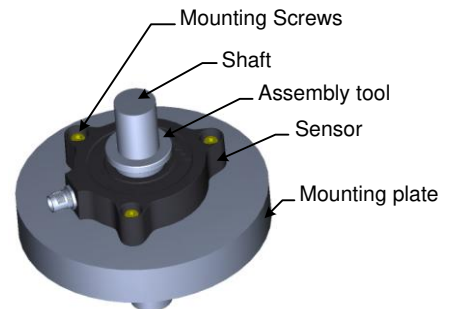

# Rotary Configuration

Figure 4. Sensor Mounting Examples

**General**

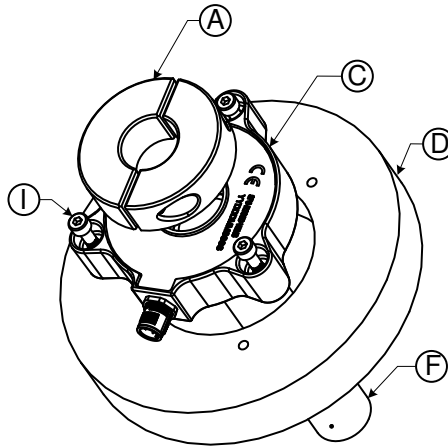

**Through Shaft**

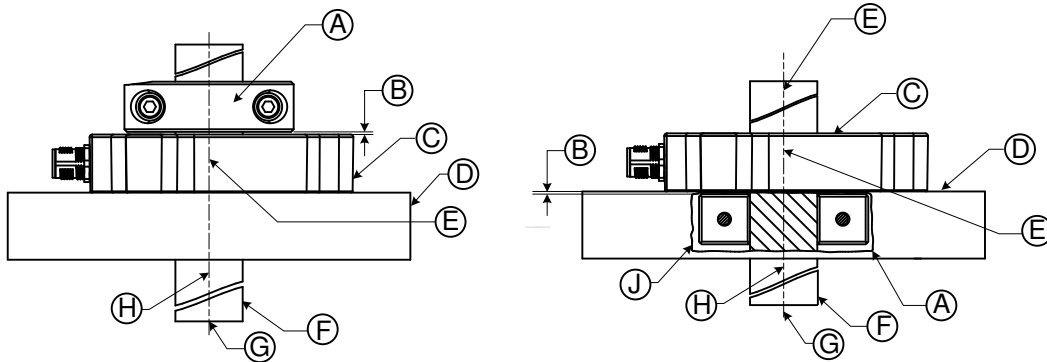



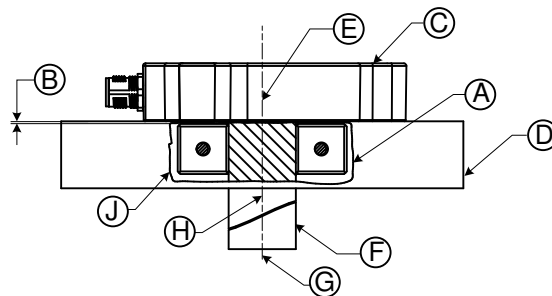

**Blind Shaft**



- A** = Magnet collar (purchased separately)
- B** = Air gap (3,0 mm  $\pm$ 2,0 mm [0.118 in  $\pm$ 0.079 in] typ.)
- C** = Sensor
- D** = Mounting plate (customer supplied - provides surface to mount sensor)
- E** = Sensor axis
- F** = Shaft (customer supplied - provides shaft to attach magnet actuator)
- G** = Radial alignment (see Table 1)
- H** = Shaft axis
- I** = Mounting screws (customer supplied - M5 or UNC 10-24)
- J** = Recess

## Order Guide

Catalog Listing	Description	
SPS-R360D-NBMS0101	SMART Position Sensor, rotary configuration, 360° sensing range, 4 mA to 20 mA output (magnet collar not included)	
SPS-MAG-002 <sup>1</sup>	Magnet collar for 25,4 mm [1 in] corresponding shaft diameter (sold separately)	
SPS-AUX-AS100-1 <sup>1</sup>	Assembly tool, one piece, 25,4 mm [1 in], aluminum (sold separately)	
SPS-AUX-AS100-2 <sup>1</sup>	Assembly tool, two piece, 25,4 mm [1 in], aluminum (sold separately)	

**Note 1:** Custom sizes are available if volume thresholds are met.

### **WARNING**

#### **PERSONAL INJURY**

DO NOT USE these products as safety or emergency stop devices or in any other application where failure of the product could result in personal injury.

**Failure to comply with these instructions could result in death or serious injury.**

#### **WARRANTY/REMEDY**

Honeywell warrants goods of its manufacture as being free of defective materials and faulty workmanship. Honeywell's standard product warranty applies unless agreed to otherwise by Honeywell in writing; please refer to your order acknowledgement or consult your local sales office for specific warranty details. If warranted goods are returned to Honeywell during the period of coverage, Honeywell will repair or replace, at its option, without charge those items it finds defective. **The foregoing is buyer's sole remedy and is in lieu of all other warranties, expressed or implied, including those of merchantability and fitness for a particular purpose. In no event shall Honeywell be liable for consequential, special, or indirect damages.**

While we provide application assistance personally, through our literature and the Honeywell web site, it is up to the customer to determine the suitability of the product in the application.

Specifications may change without notice. The information we supply is believed to be accurate and reliable as of this printing. However, we assume no responsibility for its use.

Sensing and Control  
Honeywell  
1985 Douglas Drive North  
Golden Valley, MN 55422  
[www.honeywell.com](http://www.honeywell.com)

005948-2-EN  
July 2012  
Copyright © 2012 Honeywell International Inc. All rights reserved.

### **WARNING**

#### **MISUSE OF DOCUMENTATION**

- The information presented in this product sheet is for reference only. Do not use this document as a product installation guide.
- Complete installation, operation, and maintenance information is provided in the instructions supplied with each product.

**Failure to comply with these instructions could result in death or serious injury.**

#### **SALES AND SERVICE**

Honeywell serves its customers through a worldwide network of sales offices, representatives and distributors. For application assistance, current specifications, pricing or name of the nearest Authorized Distributor, contact your local sales office or:

**E-mail:** [info.sc@honeywell.com](mailto:info.sc@honeywell.com)

**Internet:** [www.honeywell.com/sensing](http://www.honeywell.com/sensing)

#### **Phone and Fax:**

Asia Pacific	+65 6355-2828 +65 6445-3033 Fax
Europe	+44 (0) 1698 481481 +44 (0) 1698 481676 Fax
Latin America	+1-305-805-8188 +1-305-883-8257 Fax
USA/Canada	+1-800-537-6945 +1-815-235-6847 +1-815-235-6545 Fax

# Honeywell