

MATERIAL

Glass-fibre reinforced polyamide (PA) SUPER-technopolymer, black or grey colour RAL 7040 (C33), matte finish.

ROTATING PIN

Glass-fibre reinforced polyamide based (PA) technopolymer, black or grey colour RAL 7040 (C33).

ASSEMBLY KIT (SEE ASSEMBLY):

- n°4 technopolymer covers (fig.1).
- n°4 technopolymer bushings (fig.2 and fig.3).

MOUNTING

- CFMW. hinge can be assembled in three different modes:
- With M6 UNI 5933 ISO 10642 countersunk-head screw (not supplied) and screw cover supplied in the kit (fig. 1) to avoid free access to screws.
 - With cylindrical-head screw with hexagon socket M6 UNI 5931 ISO 4762 (not supplied) to set with the bushing supplied in the kit (fig.2).
 - With M6 UNI 5588 ISO 4032 nut (not supplied) and the bushing supplied in the kit (fig.3). This kind of assembly makes the hinge totally tamper-proof preventing any tampering.

FEATURES AND APPLICATIONS

The different assembly options make this product easy to install on the most common aluminium profiles (30 mm minimum side). CFMW. hinge can be assembled with CFSW. hinge with built-in safety switch CFSW. (on page 1474).

ROTATION ANGLE (APPROXIMATE VALUE)

Max 180° (0° and +180° being 0° the condition where the two interconnected surfaces are on the same plane). Do not exceed the rotation angle limit so as not to prejudice the hinge mechanical performance. The condition where the two interconnected surfaces are on the same plane is to be strictly verified because the hinge must not be stressed by any negative angle (fig.4). To choose the convenient type and the right number of hinges for your application, see the Guidelines (see page 1448).

Resistance tests	AXIAL STRESS	RADIAL STRESS	90° ANGLED STRESS
Description	Max limit static load Sa [N]	Max limit static load Sr [N]	Max limit static load S90 [N]
CFMW.70	2100	2800	1300
CFMW.110	2100	2800	1300

The max static load is the value above which the material may break thus prejudicing the hinge functionality. Obviously, a suitable factor, according to the importance and the safety level of the specific application must be applied to this value.

Conversion Table	
1 mm = 0.039 inch	
mm	inch
70	2.76
110	4.33

Code	Description	Code	Description	L	B	f±0.25	f1±0.25	H	h1	h2	d	d3	d4	C# [Nm]	⚖️
425951	CFMW.70-SH-6	425951-C33	CFMW.70-SH-6-C33	70	60	50	42	25	15	15	13.5	6.5	12	5	80
425956	CFMW.110-SH-6	425956-C33	CFMW.110-SH-6-C33	110	60	91	42	25	15	15	12	6.5	12	5	125

Suggested tightening torque for assembly screws.



ELESA Original design

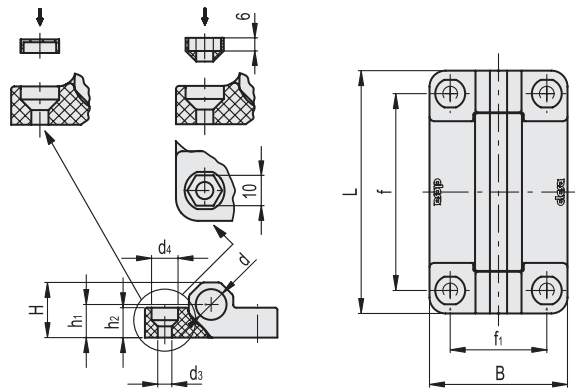
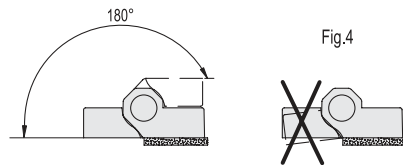
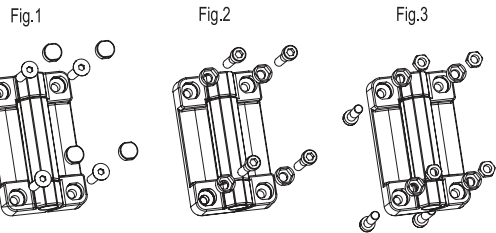

METRIC

- 1
- 2
- 3
- 4
- 5
- 6
- 7
- 8
- 9
- 10
- 11
- 12
- 13
- 14
- 15
- 16
- 17
- 18

Hinges and accessories