

Important notice

Dear Customer,

On 7 February 2017 the former NXP Standard Product business became a new company with the tradename **Nexperia**. Nexperia is an industry leading supplier of Discrete, Logic and PowerMOS semiconductors with its focus on the automotive, industrial, computing, consumer and wearable application markets

In data sheets and application notes which still contain NXP or Philips Semiconductors references, use the references to Nexperia, as shown below.

Instead of <http://www.nxp.com>, <http://www.philips.com/> or <http://www.semiconductors.philips.com/>, use <http://www.nexperia.com>

Instead of sales.addresses@www.nxp.com or sales.addresses@www.semiconductors.philips.com, use salesaddresses@nexperia.com (email)

Replace the copyright notice at the bottom of each page or elsewhere in the document, depending on the version, as shown below:

- © NXP N.V. (year). All rights reserved or © Koninklijke Philips Electronics N.V. (year). All rights reserved

Should be replaced with:

- © **Nexperia B.V. (year). All rights reserved.**

If you have any questions related to the data sheet, please contact our nearest sales office via e-mail or telephone (details via salesaddresses@nexperia.com). Thank you for your cooperation and understanding,

Kind regards,

Team Nexperia

74AVC16374

16-bit edge triggered D-type flip-flop; 3.6 V tolerant; 3-state

Rev. 3 — 16 August 2013

Product data sheet

1. General description

The 74AVC16374 is a 16-bit edge triggered flip-flop featuring separate D-type inputs for each flip-flop and 3-state outputs for bus-oriented applications. The 74AVC16374 consist of 2 sections of 8 edge-triggered flip-flops. A clock input (CP) and an output enable (\overline{OE}) are provided per 8-bit section.

The 74AVC16374 is designed to have an extremely fast propagation delay and a minimum amount of power consumption.

To ensure the high-impedance output state during power-up or power-down, \overline{nOE} should be tied to VCC through a pull-up resistor (Live Insertion).

A Dynamic Controlled Output (DCO) circuitry is implemented to support termination line drive during transient (see [Figure 5](#) and [Figure 6](#)).

2. Features and benefits

- Wide supply voltage range from 1.2 V to 3.6 V
- Complies with JEDEC standards:
 - ◆ JESD8-7 (1.2 V to 1.95 V)
 - ◆ JESD8-5 (1.8 V to 2.7 V)
 - ◆ JESD8-1A (2.7 V to 3.6 V)
- CMOS low power consumption
- Input/output tolerant up to 3.6 V
- Dynamic Controlled Output (DCO) circuit dynamically changes output impedance, resulting in noise reduction without speed degradation
- Low inductance multiple V_{CC} and GND pins to minimize noise and ground bounce
- Supports Live Insertion

3. Ordering information

Table 1. Ordering information

Type number	Package			Version
	Temperature range	Name	Description	
74AVC16374DGG	-40 °C to +85 °C	TSSOP48	plastic thin shrink small outline package; 48 leads; body width 6.1 mm	SOT362-1



4. Functional diagram

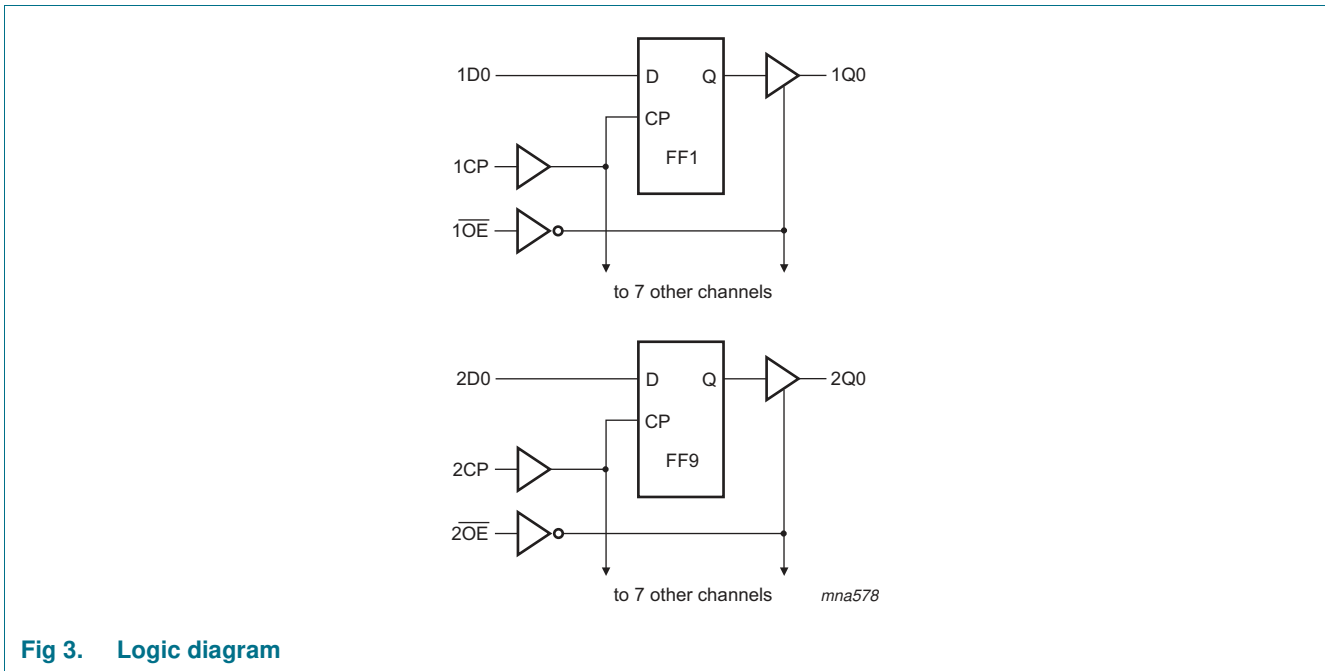
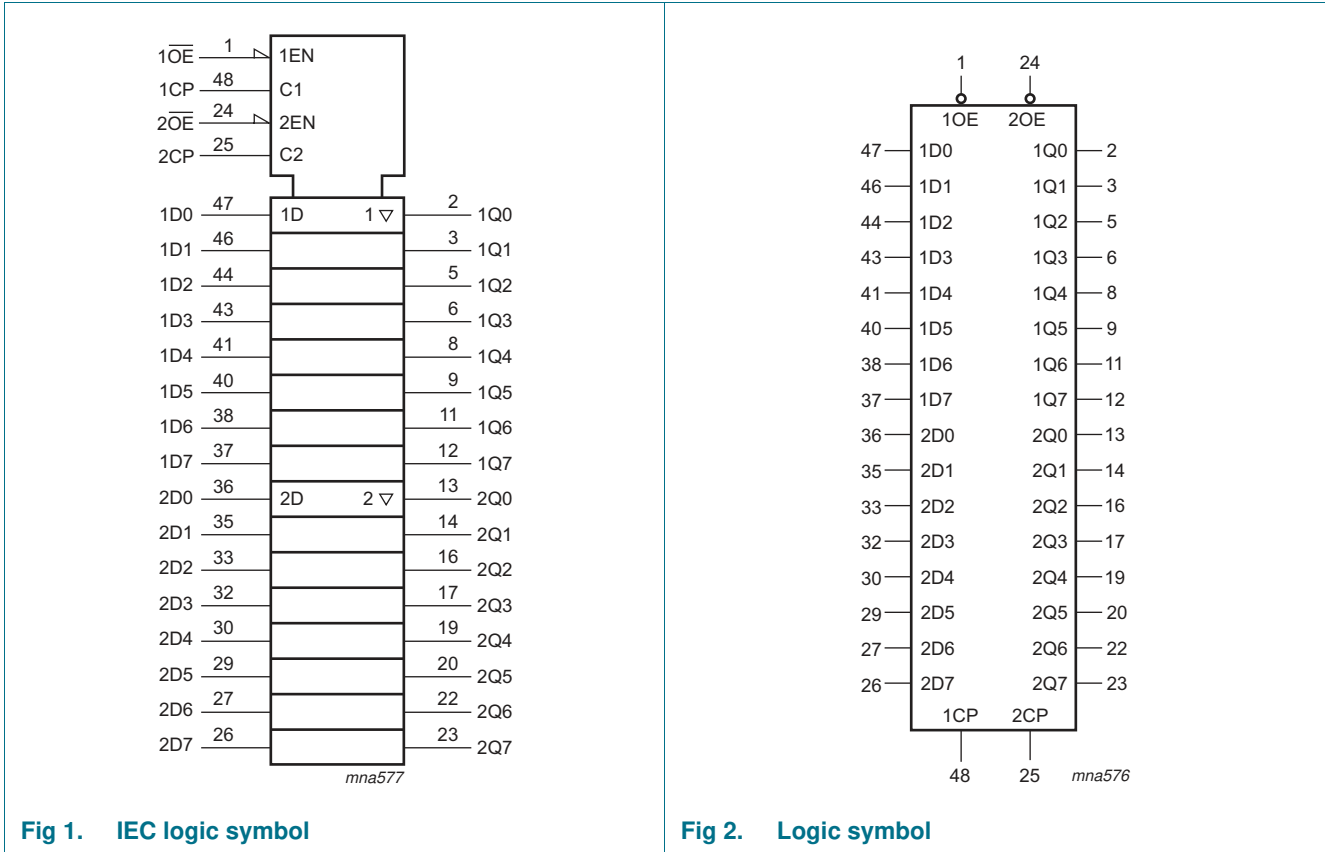

5. Pinning information

5.1 Pinning

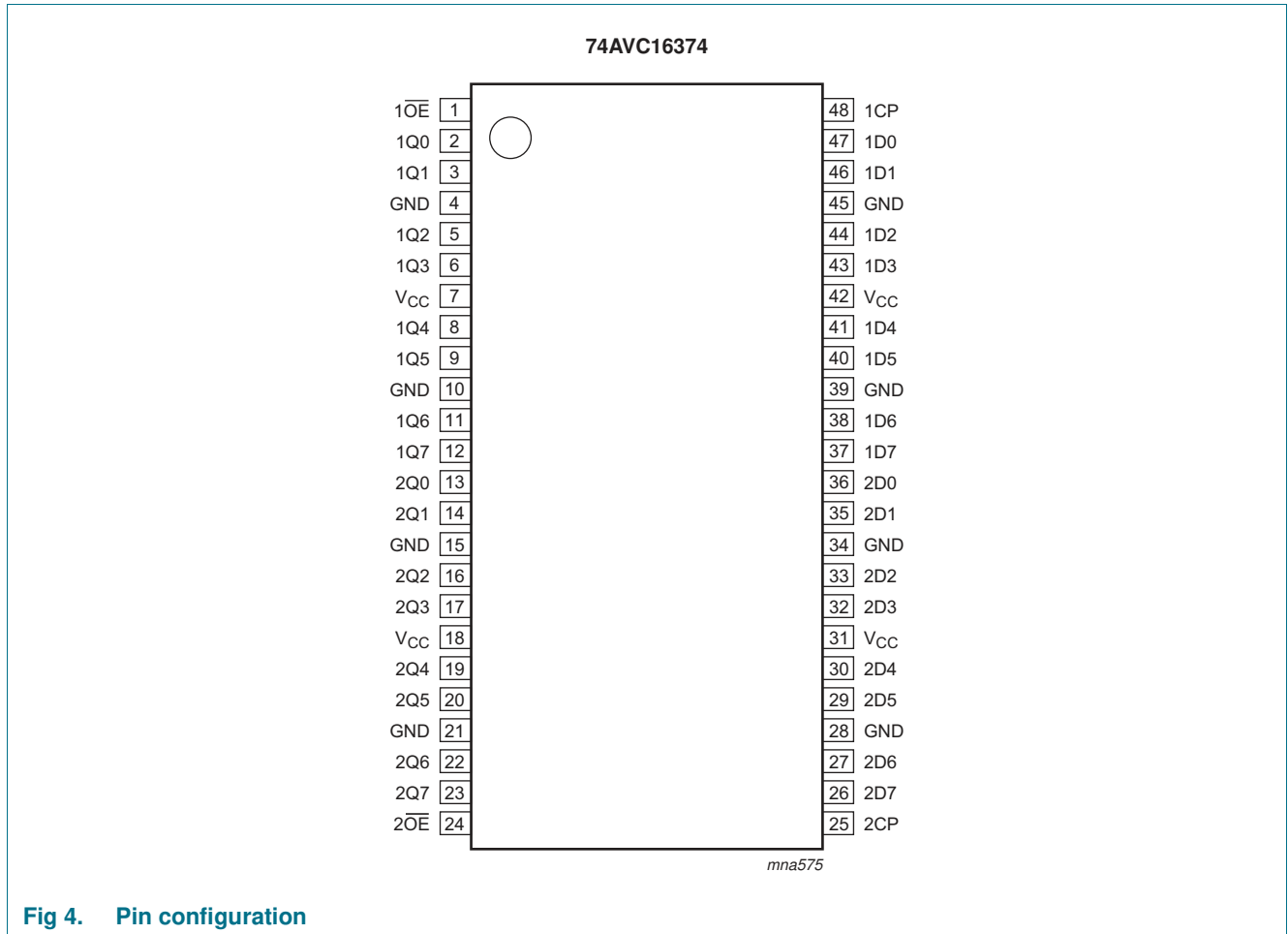

5.2 Pin description

Table 2. Pin description

Symbol	Pin	Description
$1\overline{OE}$	1	output enable input (active LOW)
1Q0 to 1Q7	2, 3, 5, 6, 8, 9, 11, 12	3-state flip-flop outputs
GND	4, 10, 15, 21, 28, 34, 39, 45	ground (0 V)
V _{CC}	7, 18, 31, 42	supply voltage
2Q0 to 2Q7	13, 14, 16, 17, 19, 20, 22, 23	3-state flip-flop outputs
$2\overline{OE}$	24	output enable input (active LOW)
2CP	25	clock input
2D0 to 2D7	36, 35, 33, 32, 30, 29, 27, 26	data input/output
1D0 to 1D7	47, 46, 44, 43, 41, 40, 38, 37	data input/output
1CP	48	clock input

6. Functional description

Table 3. Function table^[1]

Operating modes	Inputs			Internal flip-flops	Outputs
	$n\overline{OE}$	nCp	nDn		
Load and read register	L	↑	l	L	L
	L	↑	h	H	H
Load register and disable outputs	H	↑	l	L	Z
	H	↑	h	H	Z

- [1] H = HIGH voltage level
h = HIGH voltage level one set-up time prior to the LOW-to-HIGH CP transition
L = LOW voltage level
l = LOW voltage level one set-up time prior to the LOW-to-HIGH CP transition
Z = high-impedance OFF-state
↑ = LOW-to-HIGH CP transition

7. Limiting values

Table 4. Limiting values

In accordance with the Absolute Maximum Rating System (IEC 60134). Voltages are referenced to GND (ground = 0 V).

Symbol	Parameter	Conditions	Min	Max	Unit
V _{CC}	supply voltage		-0.5	+4.6	V
I _{IK}	input clamping current	V _I < 0 V	-	-50	mA
V _I	input voltage		[1] -0.5	+4.6	V
I _{OK}	output clamping current	V _O < 0 V	-50	-	mA
V _O	output voltage	output HIGH or LOW	[1] -0.5	V _{CC} + 0.5	V
		output 3-state	[1] -0.5	+4.6	V
I _O	output current	V _O = 0 V to V _{CC}	-	±50	mA
I _{CC}	supply current		-	+100	mA
I _{GND}	ground current		-100	-	mA
T _{stg}	storage temperature		-65	+150	°C
P _{tot}	total power dissipation	T _{amb} = -40 °C to +85 °C	[2] -	500	mW

[1] The input and output voltage ratings may be exceeded if the input and output current ratings are observed.

[2] Above 60 °C, the value of P_{tot} derates linearly with 5.5 mW/K.

8. Recommended operating conditions

Table 5. Recommended operating conditions

Symbol	Parameter	Conditions	Min	Typ	Max	Unit
V _{CC}	supply voltage	according to JEDEC Low Voltage Standards	1.4	-	1.6	V
			1.65	-	1.95	V
			2.3	-	2.7	V
			3.0	-	3.6	V
		for low-voltage applications	1.2	-	3.6	V
V _I	input voltage		0	-	3.6	V
V _O	output voltage	output HIGH or LOW	0	-	V _{CC}	V
		output 3-state	0	-	3.6	V
T _{amb}	ambient temperature	in free air	-40	-	+85	°C
Δt/ΔV	input transition rise and fall rate	V _{CC} = 1.4 V to 1.6 V	0	-	40	ns/V
		V _{CC} = 1.65 V to 2.3 V	0	-	30	ns/V
		V _{CC} = 2.3 V to 3.0 V	0	-	20	ns/V
		V _{CC} = 3.0 V to 3.6 V	0	-	10	ns/V

9. Static characteristics

Table 6. Static characteristics

At recommended operating conditions. Voltages are referenced to GND (ground = 0 V).

Symbol	Parameter	Conditions	Min	Typ ^[1]	Max	Unit
T_{amb} = -40 °C to +85 °C						
V _{IH}	HIGH-level input voltage	V _{CC} = 1.2 V	V _{CC}	-	-	V
		V _{CC} = 1.4 V to 1.6 V	0.65 × V _{CC}	0.9	-	V
		V _{CC} = 1.65 V to 1.95 V	0.65 × V _{CC}	0.9	-	V
		V _{CC} = 2.3 V to 2.7 V	1.7	1.2	-	V
		V _{CC} = 3.0 V to 3.6 V	2.0	1.5	-	V
V _{IL}	LOW-level input voltage	V _{CC} = 1.2 V	-	-	GND	V
		V _{CC} = 1.4 V to 1.6 V	-	0.9	0.35 × V _{CC}	V
		V _{CC} = 1.65 V to 1.95 V	-	0.9	0.35 × V _{CC}	V
		V _{CC} = 2.3 V to 2.7 V	-	1.2	0.7	V
		V _{CC} = 3.0 V to 3.6 V	-	1.5	0.8	V
V _{OH}	HIGH-level output voltage	V _I = V _{IH} or V _{IL}				
		I _O = -100 μA; V _{CC} = 1.65 V to 3.6 V	V _{CC} - 0.20	V _{CC}	-	V
		I _O = -3 mA; V _{CC} = 1.4 V	V _{CC} - 0.35	V _{CC} - 0.23	-	V
		I _O = -4 mA; V _{CC} = 1.65 V	V _{CC} - 0.45	V _{CC} - 0.25	-	V
		I _O = -8 mA; V _{CC} = 2.3 V	V _{CC} - 0.55	V _{CC} - 0.38	-	V
V _{OL}	LOW-level output voltage	V _I = V _{IH} or V _{IL}				
		I _O = 100 μA; V _{CC} = 1.65 V to 3.6 V	-	GND	0.20	V
		I _O = 3 mA; V _{CC} = 1.4 V	-	0.10	0.35	V
		I _O = 4 mA; V _{CC} = 1.65 V	-	0.10	0.45	V
		I _O = 8 mA; V _{CC} = 2.3 V	-	0.26	0.55	V
I _O	input leakage current	I _O = 12 mA; V _{CC} = 3.0 V	V _{CC} - 0.70	V _{CC} - 0.48	-	V
		I _O = 12 mA; V _{CC} = 3.0 V				
I _I	input leakage current	per pin; V _I = V _{CC} or GND; V _{CC} = 1.4 V to 3.6 V	-	0.1	2.5	μA
I _{OFF}	power-off leakage current	V _I or V _O = 3.6 V; V _{CC} = 0.0 V	-	±0.1	±10	μA
I _{OZ}	OFF-state output current	V _I = V _{IH} or V _{IL} ; V _O = V _{CC} or GND				
		V _{CC} = 1.4 V to 2.7 V	-	0.1	5	μA
		V _{CC} = 3.0 V to 3.6 V	-	0.1	10	μA
I _{CC}	supply current	V _I = V _{CC} or GND; I _O = 0 A				
		V _{CC} = 1.4 V to 2.7 V	-	0.1	20	μA
		V _{CC} = 3.0 V to 3.6 V	-	0.2	40	μA
C _I	input capacitance		-	5	-	pF

[1] All typical values are measured at T_{amb} = 25 °C.

9.1 Graphs

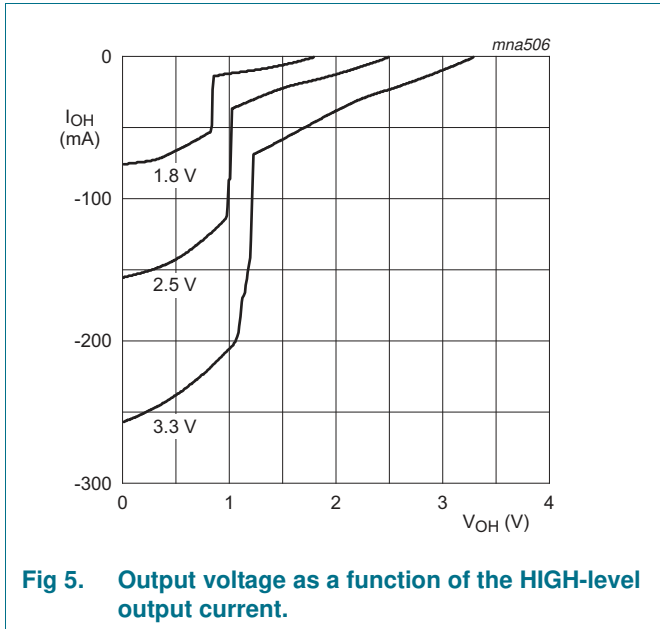

Fig 5. Output voltage as a function of the HIGH-level output current.

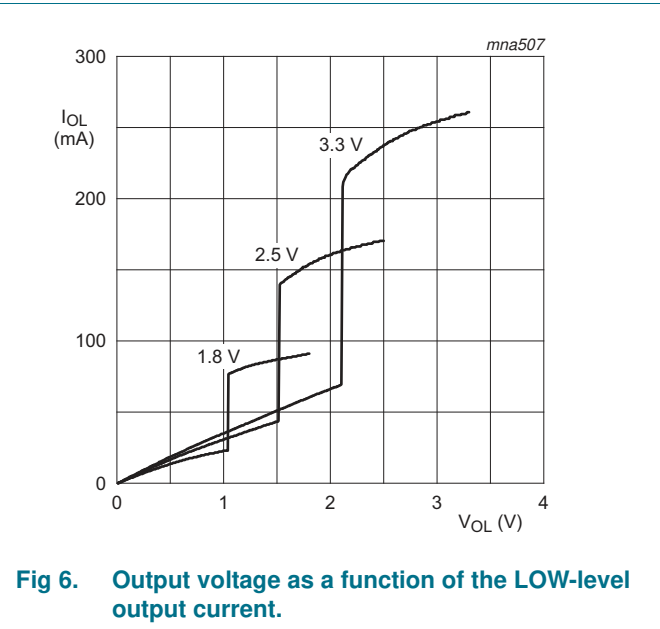

Fig 6. Output voltage as a function of the LOW-level output current.

10. Dynamic characteristics

Table 7. Dynamic characteristics

Voltages are referenced to GND (ground = 0 V). $t_r = t_f \leq 2$ ns. For test circuit, see Figure 10.

Symbol	Parameter	Conditions	-40 °C to +85 °C			Unit
			Min	Typ ^[2]	Max	
t_{pd}	propagation delay	nCP to nQn; see Figure 7 ^[1]				
		$V_{CC} = 1.2$ V	-	3.1	-	ns
		$V_{CC} = 1.4$ V to 1.6 V	1.2	2.4	8.4	ns
		$V_{CC} = 1.65$ V to 1.95 V	1.0	2.0	6.7	ns
		$V_{CC} = 2.3$ V to 2.7 V	0.8	1.5	4.1	ns
		$V_{CC} = 3.0$ V to 3.6 V	0.7	1.3	3.3	ns
t_{en}	enable time	nOE to nQn, nBn; see Figure 8 ^[1]				
		$V_{CC} = 1.2$ V	-	5.4	-	ns
		$V_{CC} = 1.4$ V to 1.6 V	1.6	3.9	8.5	ns
		$V_{CC} = 1.65$ V to 1.95 V	2.3	3.3	6.7	ns
		$V_{CC} = 2.3$ V to 2.7 V	0.9	2.3	4.3	ns
		$V_{CC} = 3.0$ V to 3.6 V	0.7	2.0	3.4	ns
t_{dis}	disable time	nOE to nQn; see Figure 8 ^[1]				
		$V_{CC} = 1.2$ V	-	5.6	-	ns
		$V_{CC} = 1.4$ V to 1.6 V	2.5	4.5	9.4	ns
		$V_{CC} = 1.65$ V to 1.95 V	1.8	3.3	7.8	ns
		$V_{CC} = 2.3$ V to 2.7 V	1.0	1.8	4.2	ns
		$V_{CC} = 3.0$ V to 3.6 V	1.2	2.0	3.9	ns

Table 7. Dynamic characteristics ...continued

Voltages are referenced to GND (ground = 0 V). $t_r = t_f \leq 2$ ns. For test circuit, see [Figure 10](#).

Symbol	Parameter	Conditions	-40 °C to +85 °C			Unit
			Min	Typ ^[2]	Max	
t _w	pulse width	HIGH; nCP; see Figure 7				
		V _{CC} = 1.2 V	-	0.8	-	ns
		V _{CC} = 1.4 V to 1.6 V	-	0.5	-	ns
		V _{CC} = 1.65 V to 1.95 V	3.1	0.3	-	ns
		V _{CC} = 2.3 V to 2.7 V	2.5	0.2	-	ns
		V _{CC} = 3.0 V to 3.6 V	2.5	0.2	-	ns
t _{su}	set-up time	nDn to nCP; see Figure 8				
		V _{CC} = 1.2 V	-	-0.6	-	ns
		V _{CC} = 1.4 V to 1.6 V	2.7	-0.3	-	ns
		V _{CC} = 1.65 V to 1.95 V	1.9	-0.3	-	ns
		V _{CC} = 2.3 V to 2.7 V	1.4	-0.2	-	ns
		V _{CC} = 3.0 V to 3.6 V	1.4	-0.1	-	ns
t _h	hold time	nDn to nCP; see Figure 8				
		V _{CC} = 1.2 V	-	0.8	-	ns
		V _{CC} = 1.4 V to 1.6 V	1.3	0.7	-	ns
		V _{CC} = 1.65 V to 1.95 V	1.2	0.6	-	ns
		V _{CC} = 2.3 V to 2.7 V	1.1	0.5	-	ns
		V _{CC} = 3.0 V to 3.6 V	1.1	0.4	-	ns
f _{max}	maximum frequency	see Figure 8				
		V _{CC} = 1.2 V	-	250	-	MHz
		V _{CC} = 1.4 V to 1.6 V	-	300	-	MHz
		V _{CC} = 1.65 V to 1.95 V	160	320	-	MHz
		V _{CC} = 2.3 V to 2.7 V	200	350	-	MHz
		V _{CC} = 3.0 V to 3.6 V	200	350	-	MHz
C _{PD}	power dissipation capacitance	per input; V _I = GND to V _{CC}				
		outputs enabled	-	66	-	pF
		outputs disabled	-	1	-	pF

[1] t_{pd} is the same as t_{PLH} and t_{PHL}.
t_{en} is the same as t_{PZL} and t_{PZH}.
t_{dis} is the same as t_{PLZ} and t_{PHZ}.

[2] Typical values are measured at T_{amb} = 25 °C and V_{CC} = 1.2 V, 1.5 V, 1.8 V, 2.5 V and 3.3 V respectively.

[3] C_{PD} is used to determine the dynamic power dissipation (P_D in μW).

$$P_D = C_{PD} \times V_{CC}^2 \times f_i \times N + \Sigma(C_L \times V_{CC}^2 \times f_o) \text{ where:}$$

f_i = input frequency in MHz; f_o = output frequency in MHz

C_L = output load capacitance in pF

V_{CC} = supply voltage in Volts

N = number of inputs switching

Σ(C_L × V_{CC}² × f_o) = sum of the outputs.

11. Waveforms

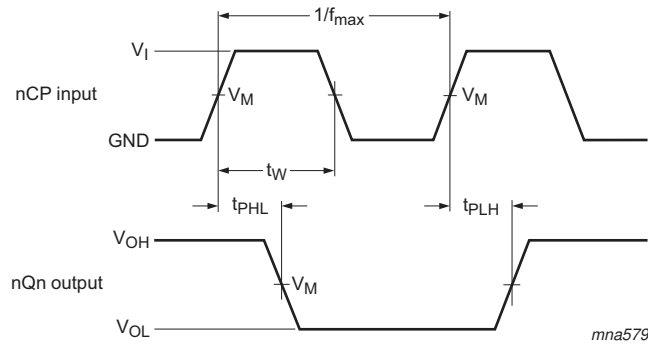

Measurement points are given in [Table 9](#).
 Logic levels: V_{OL} and V_{OH} are typical output voltage levels that occur with the output load.

Fig 7. Clock input (nCP) to output (nQn) propagation delays

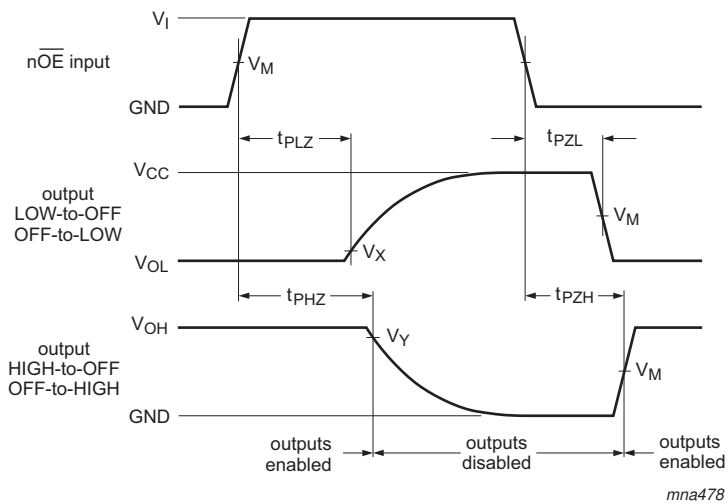

Measurement points are given in [Table 9](#).
 Logic levels: V_{OL} and V_{OH} are typical output voltage levels that occur with the output load.

Fig 8. 3-state enable and disable times

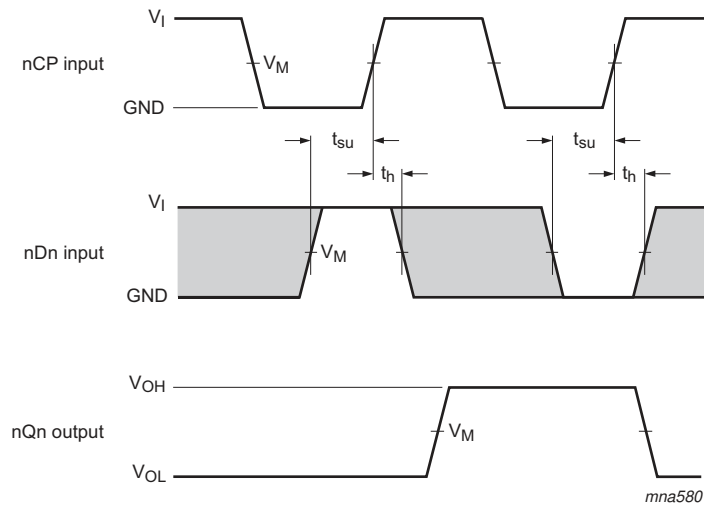

Measurement points are given in [Table 9](#).
 Logic levels: V_{OL} and V_{OH} are typical output voltage levels that occur with the output load.

Fig 9. Data set-up and hold times for nDn input to nCP input

Table 8. Measurement points

Supply voltage	V_M	Input			
		V_I	$t_r = t_f$	V_X	V_Y
1.2 V	$0.5 \times V_{CC}$	V_{CC}	≤ 2 ns	$V_{OL} + 0.15$ V	$V_{OH} - 0.15$ V
1.4 V to 1.6 V	$0.5 \times V_{CC}$	V_{CC}	≤ 2 ns	$V_{OL} + 0.15$ V	$V_{OH} - 0.15$ V
1.65 V to 1.95 V	$0.5 \times V_{CC}$	V_{CC}	≤ 2 ns	$V_{OL} + 0.15$ V	$V_{OH} - 0.15$ V
2.3 V to 2.7 V	$0.5 \times V_{CC}$	V_{CC}	≤ 2 ns	$V_{OL} + 0.15$ V	$V_{OH} - 0.15$ V
3.0 V to 3.6 V	$0.5 \times V_{CC}$	V_{CC}	≤ 2 ns	$V_{OL} + 0.3$ V	$V_{OH} - 0.3$ V

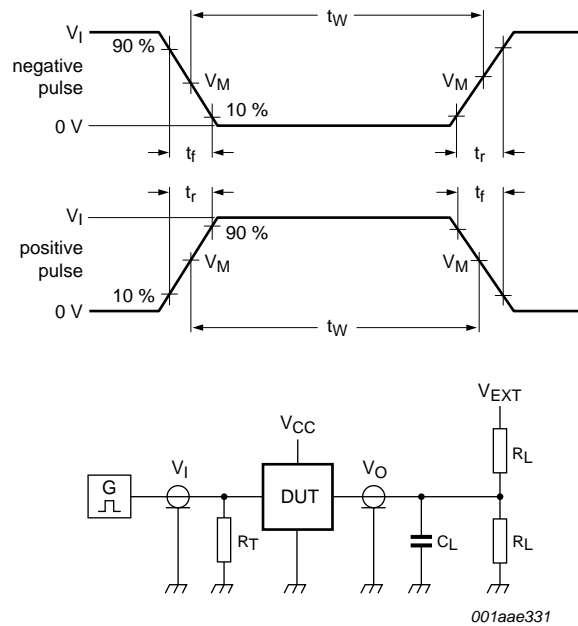

Test data is given in [Table 9](#).

Definitions for test circuit:

R_L = Load resistance.

C_L = Load capacitance including jig and probe capacitance.

R_T = Termination resistance should be equal to output impedance Z_o of the pulse generator.

V_{EXT} = External voltage for measuring switching times.

Fig 10. Test circuit for measuring switching times

Table 9. Test data

Supply voltage	Input		Load		V_{EXT}		
	V_I	t_r, t_f	C_L	R_L	t_{PLH}, t_{PHL}	t_{PLZ}, t_{PZL}	t_{PHZ}, t_{PZH}
1.2 V	V_{CC}	≤ 2 ns	15 pF	2 k Ω	open	$2 \times V_{CC}$	GND
1.4 V to 1.6 V	V_{CC}	≤ 2 ns	15 pF	2 k Ω	open	$2 \times V_{CC}$	GND
1.65 V to 1.95 V	V_{CC}	≤ 2 ns	30 pF	1 k Ω	open	$2 \times V_{CC}$	GND
2.3 V to 2.7 V	V_{CC}	≤ 2 ns	30 pF	500 Ω	open	$2 \times V_{CC}$	GND
3.0 V to 3.6 V	V_{CC}	≤ 2 ns	30 pF	500 Ω	open	$2 \times V_{CC}$	GND

12. Package outline

TSSOP48: plastic thin shrink small outline package; 48 leads; body width 6.1 mm

SOT362-1

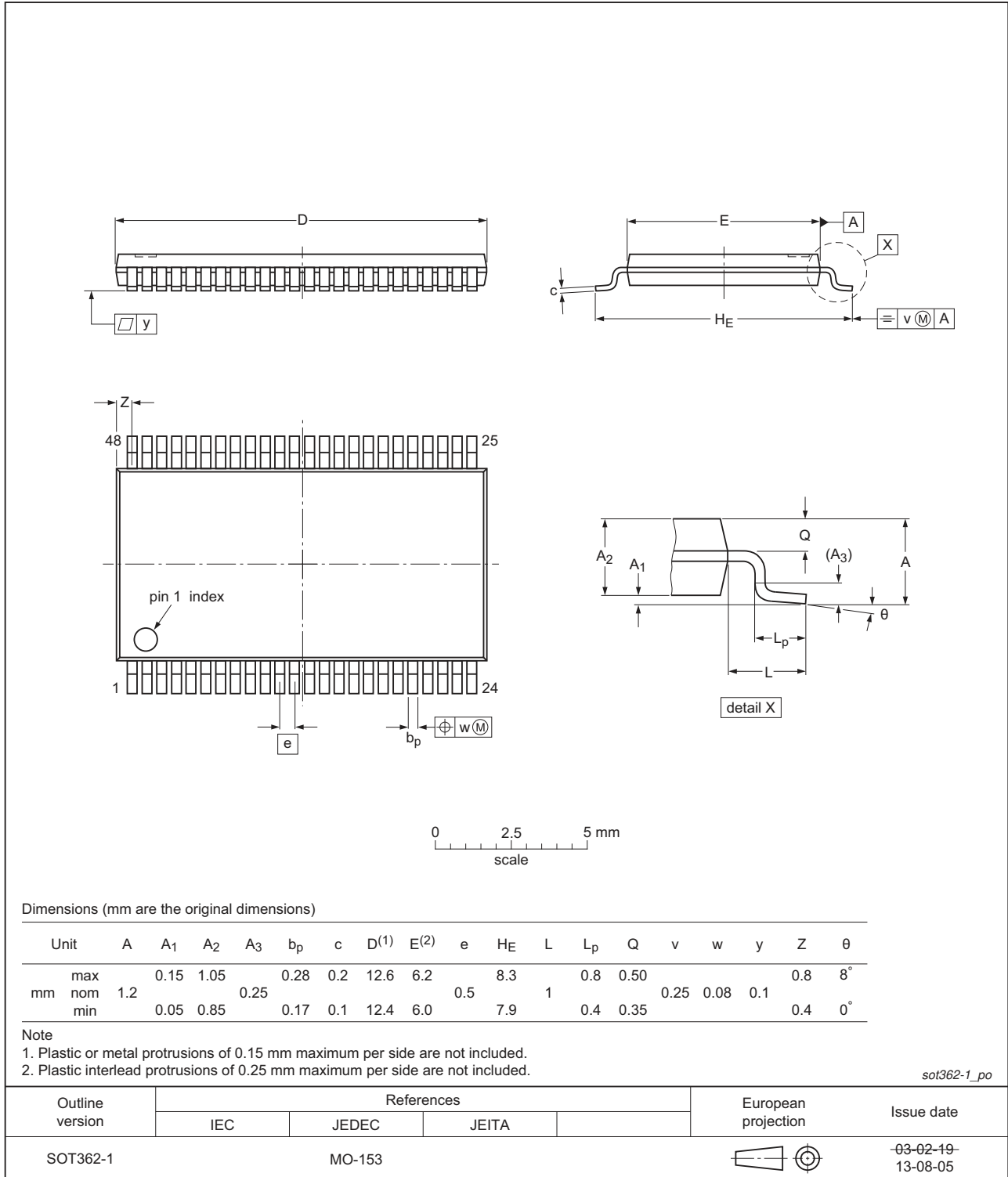

Fig 11. Package outline SOT362-1 (TSSOP48)

13. Abbreviations

Table 10. Abbreviations

Acronym	Description
CMOS	Complementary Metal-Oxide Semiconductor
DUT	Device Under Test
TTL	Transistor-Transistor Logic

14. Revision history

Table 11. Revision history

Document ID	Release date	Data sheet status	Change notice	Order number	Supersedes
74AVC16374 v.3	20130816	Product data sheet	-	-	74AVC16374 v.2
Modifications:		<ul style="list-style-type: none">The format of this data sheet has been redesigned to comply with the new identity guidelines of NXP Semiconductors.Legal texts have been adapted to the new company name where appropriate.			
74AVC16374 v.2	20000309	Product specification	-	-	74AVC16374 v.1
74AVC16374 v.1	19981211	Product specification	-	-	-

15. Legal information

15.1 Data sheet status

Document status ^{[1][2]}	Product status ^[3]	Definition
Objective [short] data sheet	Development	This document contains data from the objective specification for product development.
Preliminary [short] data sheet	Qualification	This document contains data from the preliminary specification.
Product [short] data sheet	Production	This document contains the product specification.

[1] Please consult the most recently issued document before initiating or completing a design.

[2] The term 'short data sheet' is explained in section "Definitions".

[3] The product status of device(s) described in this document may have changed since this document was published and may differ in case of multiple devices. The latest product status information is available on the Internet at URL <http://www.nxp.com>.

15.2 Definitions

Draft — The document is a draft version only. The content is still under internal review and subject to formal approval, which may result in modifications or additions. NXP Semiconductors does not give any representations or warranties as to the accuracy or completeness of information included herein and shall have no liability for the consequences of use of such information.

Short data sheet — A short data sheet is an extract from a full data sheet with the same product type number(s) and title. A short data sheet is intended for quick reference only and should not be relied upon to contain detailed and full information. For detailed and full information see the relevant full data sheet, which is available on request via the local NXP Semiconductors sales office. In case of any inconsistency or conflict with the short data sheet, the full data sheet shall prevail.

Product specification — The information and data provided in a Product data sheet shall define the specification of the product as agreed between NXP Semiconductors and its customer, unless NXP Semiconductors and customer have explicitly agreed otherwise in writing. In no event however, shall an agreement be valid in which the NXP Semiconductors product is deemed to offer functions and qualities beyond those described in the Product data sheet.

15.3 Disclaimers

Limited warranty and liability — Information in this document is believed to be accurate and reliable. However, NXP Semiconductors does not give any representations or warranties, expressed or implied, as to the accuracy or completeness of such information and shall have no liability for the consequences of use of such information. NXP Semiconductors takes no responsibility for the content in this document if provided by an information source outside of NXP Semiconductors.

In no event shall NXP Semiconductors be liable for any indirect, incidental, punitive, special or consequential damages (including - without limitation - lost profits, lost savings, business interruption, costs related to the removal or replacement of any products or rework charges) whether or not such damages are based on tort (including negligence), warranty, breach of contract or any other legal theory.

Notwithstanding any damages that customer might incur for any reason whatsoever, NXP Semiconductors' aggregate and cumulative liability towards customer for the products described herein shall be limited in accordance with the *Terms and conditions of commercial sale* of NXP Semiconductors.

Right to make changes — NXP Semiconductors reserves the right to make changes to information published in this document, including without limitation specifications and product descriptions, at any time and without notice. This document supersedes and replaces all information supplied prior to the publication hereof.

Suitability for use — NXP Semiconductors products are not designed, authorized or warranted to be suitable for use in life support, life-critical or safety-critical systems or equipment, nor in applications where failure or malfunction of an NXP Semiconductors product can reasonably be expected to result in personal injury, death or severe property or environmental damage. NXP Semiconductors and its suppliers accept no liability for inclusion and/or use of NXP Semiconductors products in such equipment or applications and therefore such inclusion and/or use is at the customer's own risk.

Applications — Applications that are described herein for any of these products are for illustrative purposes only. NXP Semiconductors makes no representation or warranty that such applications will be suitable for the specified use without further testing or modification.

Customers are responsible for the design and operation of their applications and products using NXP Semiconductors products, and NXP Semiconductors accepts no liability for any assistance with applications or customer product design. It is customer's sole responsibility to determine whether the NXP Semiconductors product is suitable and fit for the customer's applications and products planned, as well as for the planned application and use of customer's third party customer(s). Customers should provide appropriate design and operating safeguards to minimize the risks associated with their applications and products.

NXP Semiconductors does not accept any liability related to any default, damage, costs or problem which is based on any weakness or default in the customer's applications or products, or the application or use by customer's third party customer(s). Customer is responsible for doing all necessary testing for the customer's applications and products using NXP Semiconductors products in order to avoid a default of the applications and the products or of the application or use by customer's third party customer(s). NXP does not accept any liability in this respect.

Limiting values — Stress above one or more limiting values (as defined in the Absolute Maximum Ratings System of IEC 60134) will cause permanent damage to the device. Limiting values are stress ratings only and (proper) operation of the device at these or any other conditions above those given in the Recommended operating conditions section (if present) or the Characteristics sections of this document is not warranted. Constant or repeated exposure to limiting values will permanently and irreversibly affect the quality and reliability of the device.

Terms and conditions of commercial sale — NXP Semiconductors products are sold subject to the general terms and conditions of commercial sale, as published at <http://www.nxp.com/profile/terms>, unless otherwise agreed in a valid written individual agreement. In case an individual agreement is concluded only the terms and conditions of the respective agreement shall apply. NXP Semiconductors hereby expressly objects to applying the customer's general terms and conditions with regard to the purchase of NXP Semiconductors products by customer.

No offer to sell or license — Nothing in this document may be interpreted or construed as an offer to sell products that is open for acceptance or the grant, conveyance or implication of any license under any copyrights, patents or other industrial or intellectual property rights.

Export control — This document as well as the item(s) described herein may be subject to export control regulations. Export might require a prior authorization from competent authorities.

Non-automotive qualified products — Unless this data sheet expressly states that this specific NXP Semiconductors product is automotive qualified, the product is not suitable for automotive use. It is neither qualified nor tested in accordance with automotive testing or application requirements. NXP Semiconductors accepts no liability for inclusion and/or use of non-automotive qualified products in automotive equipment or applications.

In the event that customer uses the product for design-in and use in automotive applications to automotive specifications and standards, customer (a) shall use the product without NXP Semiconductors' warranty of the product for such automotive applications, use and specifications, and (b) whenever customer uses the product for automotive applications beyond

NXP Semiconductors' specifications such use shall be solely at customer's own risk, and (c) customer fully indemnifies NXP Semiconductors for any liability, damages or failed product claims resulting from customer design and use of the product for automotive applications beyond NXP Semiconductors' standard warranty and NXP Semiconductors' product specifications.

Translations — A non-English (translated) version of a document is for reference only. The English version shall prevail in case of any discrepancy between the translated and English versions.

15.4 Trademarks

Notice: All referenced brands, product names, service names and trademarks are the property of their respective owners.

16. Contact information

For more information, please visit: <http://www.nxp.com>

For sales office addresses, please send an email to: salesaddresses@nxp.com

17. Contents

1	General description	1
2	Features and benefits	1
3	Ordering information	1
4	Functional diagram	2
5	Pinning information	3
5.1	Pinning	3
5.2	Pin description	4
6	Functional description	4
7	Limiting values	5
8	Recommended operating conditions	5
9	Static characteristics	6
9.1	Graphs	7
10	Dynamic characteristics	7
11	Waveforms	9
12	Package outline	12
13	Abbreviations	13
14	Revision history	13
15	Legal information	14
15.1	Data sheet status	14
15.2	Definitions	14
15.3	Disclaimers	14
15.4	Trademarks	15
16	Contact information	15
17	Contents	16

Please be aware that important notices concerning this document and the product(s) described herein, have been included in section 'Legal information'.

© NXP B.V. 2013.

All rights reserved.

For more information, please visit: <http://www.nxp.com>

For sales office addresses, please send an email to: salesaddresses@nxp.com

Date of release: 16 August 2013

Document identifier: 74AVC16374