

THIS DRAWING IS UNPUBLISHED. RELEASED FOR PUBLICATION
 © COPYRIGHT - By - ALL RIGHTS RESERVED.

REVISIONS				
P	LTR	DESCRIPTION	DATE	APVD
B		INITIAL RELEASE	07JUL2015	MY GG

P1

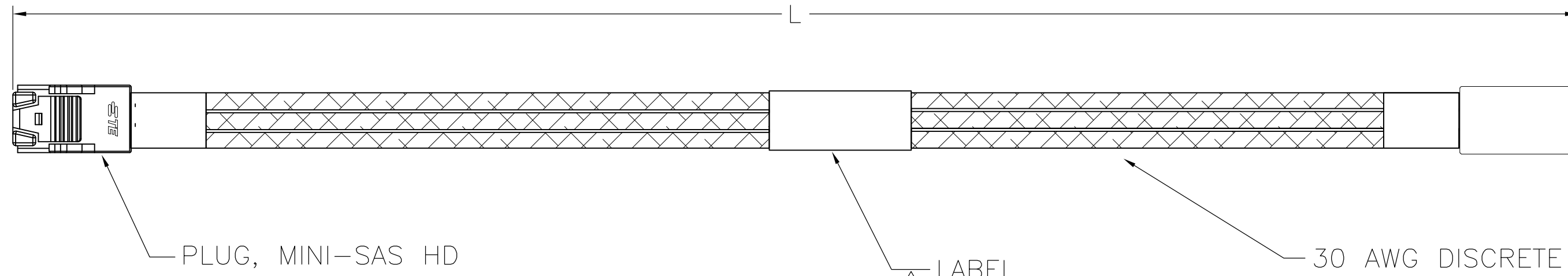
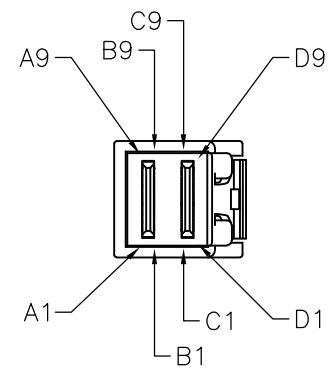

P2

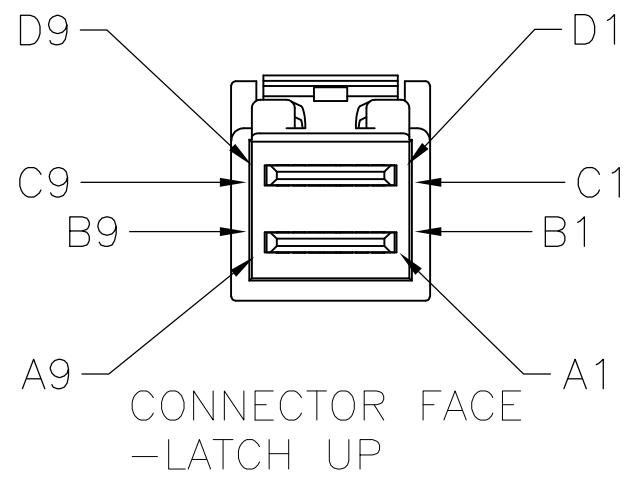
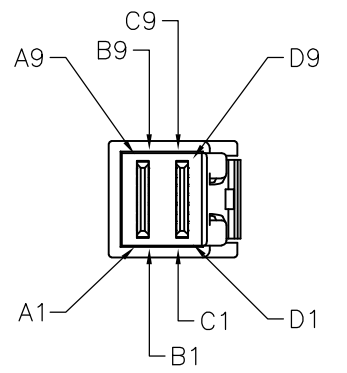

- ASSEMBLY TO BE 100% TESTED FOR CONTINUITY, SHORTS, AND OPENS, CABLES ASSEMBLYS ARE ALSO TO BE 100% TESTED FOR SIGNAL INTEGRITY, TO SAS 3.0 REQUIREMENTS.
- ROHS AND REACH COMPLIANCE: PRODUCT AND PROCESSING MEETS REQUIREMENTS OF TE SPECIFICATION TEC-138-702.

△ LABEL CENTERED AND LABEL INFORMATION AS BELOW:

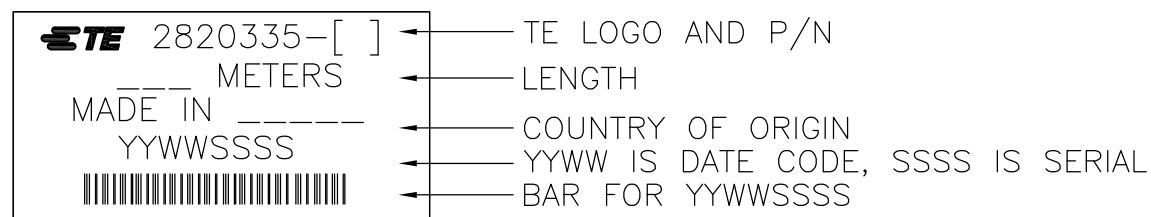

4. SEE SHEET #2 FOR WIRING SCHEMATIC.

1000	+25 -0	2820335-4
700	+25 -0	2820335-3
500	+25 -0	2820335-2
300	+25 -0	2820335-1
"L"[MM]		TE P/N

THIS DRAWING IS A CONTROLLED DOCUMENT.		DWN M.YI 16/JUN/2014	STE TE Connectivity	
DIMENSIONS: mm		CHK G.GUTGOLD 16/JUN/2014		
TOLERANCES UNLESS OTHERWISE SPECIFIED:		APVD G.GUTGOLD 16/JUN/2014	NAME C/A, INTERNAL HD MINI SAS, STR TO STR 85 OHMS, 4X 30 AWG	
0 PLC ± - 1 PLC ± - 2 PLC ± - 3 PLC ± - 4 PLC ± - ANGLES ± -		PRODUCT SPEC -	SIZE A2	
MATERIAL -		FINISH -	CAGE CODE 00779	DRAWING NO C=2820335
		WEIGHT 0	RESTRICTED TO -	
		CUSTOMER DRAWING	SCALE N.T.S.	SHEET 1 of 2
			REV B	

THIS DRAWING IS UNPUBLISHED. RELEASED FOR PUBLICATION
 © COPYRIGHT - By - ALL RIGHTS RESERVED.

REVISIONS				
P	LTR	DESCRIPTION	DATE	APVD
-	-	SEE SHEET 1	-	-

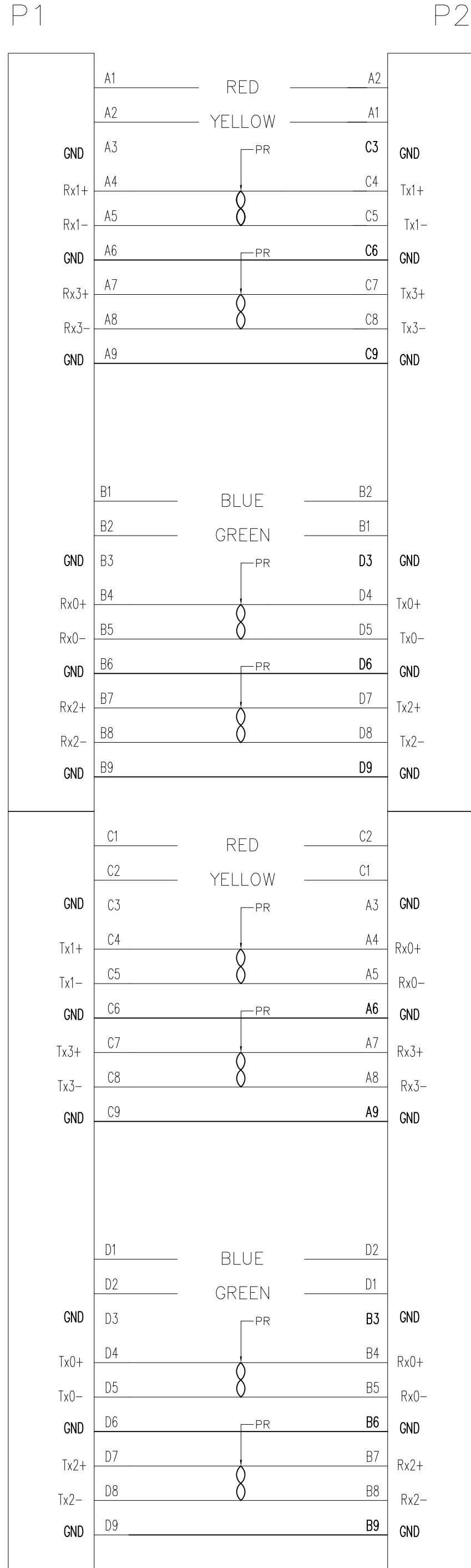

WIRING PATTERN

THIS DRAWING IS A CONTROLLED DOCUMENT.		DWN M.YI 16/JUN/2014	TE Connectivity	
DIMENSIONS: mm		CHK G.GUTGOLD 16/JUN/2014		
TOLERANCES UNLESS OTHERWISE SPECIFIED:		APVD G.GUTGOLD 16/JUN/2014	NAME C/A, INTERNAL HD MINI SAS, STR TO STR 85 OHMS, 4X 30 AWG	
		PRODUCT SPEC -	SIZE A2	
MATERIAL -		APPLICATION SPEC -	CAGE CODE 00779	DRAWING NO C=2820335
FINISH -		WEIGHT -	SCALE N.T.S.	SHEET 2 of 2
CUSTOMER DRAWING			RESTRICTED TO -	REV B

2820335