

Multiple Switch Detection Interface with Suppressed Wake-up

The 33972 Multiple Switch Detection Interface with suppressed wake-up is designed to detect the closing and opening of up to 22 switch contacts. The switch status, either open or closed, is transferred to the microprocessor unit (MCU) through a serial peripheral interface (SPI). The device also features a 22-to-1 analog multiplexer for reading inputs as analog. The analog input signal is buffered and provided on the AMUX output pin for the MCU to read.

The 33972 device has two modes of operation, Normal and Sleep. Normal mode allows programming of the device and supplies switch contacts with pull-up or pull-down current as it monitors switch change of state. The Sleep mode provides low quiescent current, which makes the 33972 ideal for automotive and industrial products requiring low sleep-state currents.

Features

- Designed to operate $5.5\text{ V} \leq V_{PWR} \leq 26\text{ V}$
- Switch input voltage range -14 V to V_{PWR} , 40 V Max
- Interfaces directly to MPU using 3.3 V/5.0 V SPI protocol
- Selectable wake-up on change of state
- Selectable wetting current (16 or 2.0 mA)
- 8 programmable inputs (switches to battery or ground)
- 14 switch-to-ground inputs
- Typical standby current - $V_{PWR} = 100\text{ }\mu\text{A}$ and $V_{DD} = 20\text{ }\mu\text{A}$
- Active interrupt ($\overline{\text{INT}}$) on change-of-switch state
- Pb-free packaging designated by suffix code EW
- Exposed pad packaging designated by suffix code EK

33972/A/T

**MULTIPLE SWITCH
 DETECTION INTERFACE**

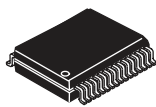

DWB SUFFIX
EW SUFFIX (Pb-FREE)
98ARH99137A
32-PIN SOICW

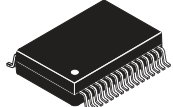

EK SUFFIX (Pb-FREE)
98ASA10556D
32-PIN SOICW EP

ORDERING INFORMATION

| Device | Temperature Range (T _A) | Package |
|----------------|-------------------------------------|----------|
| MC33972DWB/R2 | -40°C to 125°C | 32 SOICW |
| MC33972EW/R2 | | |
| MCZ33972EW/R2 | | |
| MCZ33972AEW/R2 | | |
| MC33972TDWB/R2 | | |
| MC33972TEW/R2 | | |
| MCZ33972TEW/R2 | | |
| MCZ33972AEK/R2 | | |

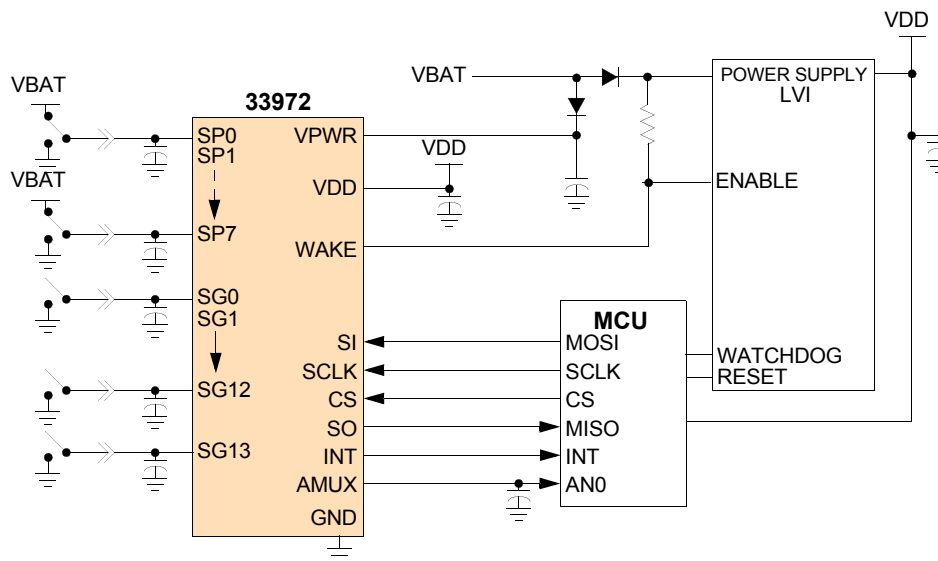

Figure 1. 33972 Simplified Application Diagram

Freescale Semiconductor, Inc. reserves the right to change the detail specifications, as may be required, to permit improvements in the design of its products.

© Freescale Semiconductor, Inc., 2009. All rights reserved.

DEVICE VARIATIONS

Table 1. Device Variations

| Device | Switch Input Voltage Range | Reference Location |
|--------|----------------------------|---------------------|
| 33972 | -14 to 38 V _{DC} | 5.6 |
| 33972A | -14 to 40 V _{DC} | 5.6 |

INTERNAL BLOCK DIAGRAM

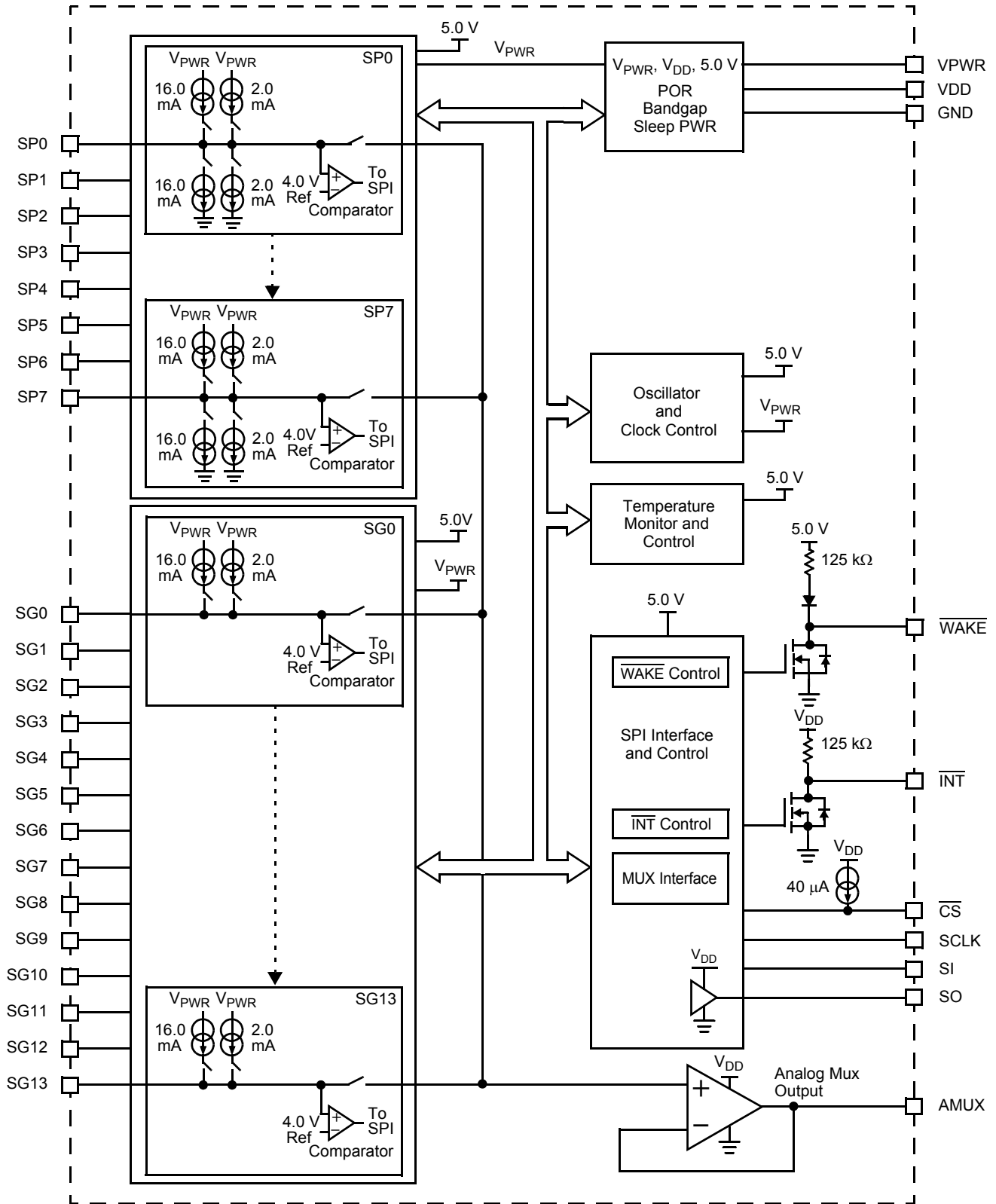

Figure 2. 33972 Simplified Internal Block Diagram

PIN CONNECTIONS

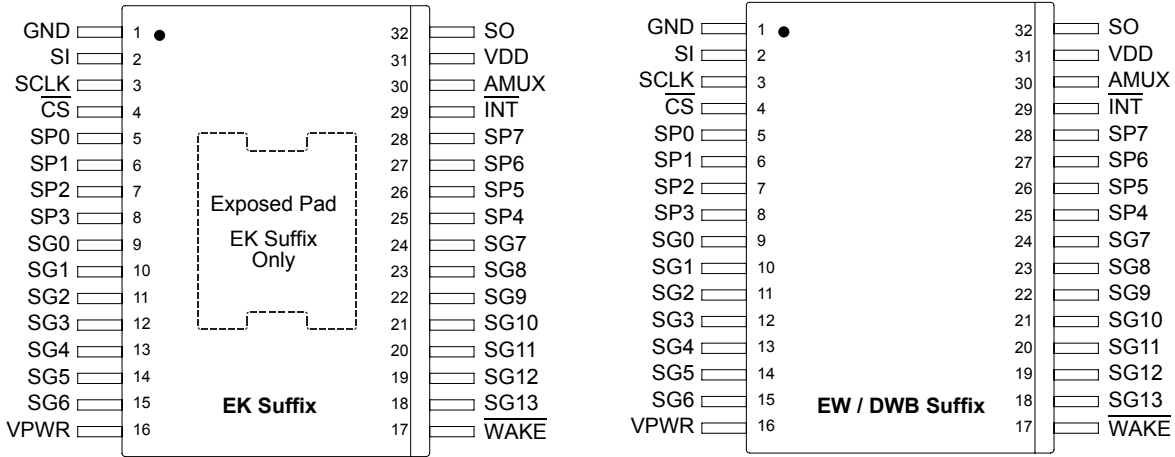

Figure 3. 33972 Pin Connections

Table 2. 33972 Pin Definitions

A functional description of each pin can be found in the Functional Pin Description section beginning on [page 10](#).

| Pin Number | Pin Name | Pin Function | Formal Name | Definition |
|----------------|--------------------------|--------------|------------------------------|--|
| 1 | GND | Ground | Ground | Ground for logic, analog, and switch to battery inputs. |
| 2 | SI | Input | SPI Slave In | SPI control data input pin from the MCU to the 33972. |
| 3 | SCLK | Input | Serial Clock | SPI control clock input pin. |
| 4 | $\overline{\text{CS}}$ | Input | Chip Select | SPI control chip select input pin from the MCU to the 33972. Logic [0] allows data to be transferred in. |
| 5–8 25–28 | SP0–3 SP4–7 | Input | Programmable Switches 0–7 | Programmable switch-to-battery or switch-to-ground input pins. |
| 9–15, 18–24 | SG0–6, SG13–7 | Input | Switch-to-Ground Inputs 0–13 | Switch-to-ground input pins. |
| 16 | VPWR | Input | Battery Input | Battery supply input pin. Pin requires external reverse battery protection. |
| 17 | $\overline{\text{WAKE}}$ | Input/Output | Wake-up | Open drain wake-up output. Designed to control a power supply enable pin. |
| 29 | $\overline{\text{INT}}$ | Input/Output | Interrupt | Open-drain output to MCU. Used to indicate an input switch change of state. |
| 30 | AMUX | Output | Analog Multiplex Output | Analog multiplex output. |
| 31 | VDD | Input | Voltage Drain Supply | 3.3/5.0V supply. Sets SPI communication level for the SO driver. |
| 32 | SO | Output | SPI Slave Out | Provides digital data from the 33972 to the MCU. |
| | EP | Ground | Exposed Pad | It is recommended that the exposed pad is terminated to GND (pin 1) and system ground, however, the device will perform as specified with the exposed pad unterminated (floating). |

ELECTRICAL CHARACTERISTICS

MAXIMUM RATINGS

Table 3. Maximum Ratings

All voltages are with respect to ground unless otherwise noted. Exceeding these ratings may cause a malfunction or permanent damage to the device.

| Ratings | Symbol | Value | Unit |
|--|-------------------|-------------|-----------------|
| ELECTRICAL RATINGS | | | |
| VDD Supply Voltage \overline{CS} , SI, SO, SCLK, \overline{INT} , AMUX ⁽¹⁾ | – | -0.3 to 7.0 | V _{DC} |
| WAKE ⁽¹⁾ | – | -0.3 to 40 | V _{DC} |
| VPWR Supply Voltage ⁽¹⁾ | – | -0.3 to 50 | V _{DC} |
| VPWR Supply Voltage at -40°C ⁽¹⁾ | – | -0.3 to 45 | V _{DC} |
| Switch Input Voltage Range | – | -14 to 40 | V _{DC} |
| Frequency of SPI Operation (V _{DD} = 5.0 V) | – | 6.0 | MHz |
| ESD Voltage ⁽³⁾ | V _{ESD} | | V |
| Human Body Model ⁽²⁾ | | ±2000 | |
| Applies to all non-input pins | | ±2000 | |
| Machine Model | | ±200 | |
| Charge Device Model | | | |
| Corner Pins | | 750 | |
| Interior Pins | 500 | | |
| THERMAL RATINGS | | | |
| Operating Temperature | | | °C |
| Ambient | T _A | -40 to 125 | |
| Junction | T _J | -40 to 150 | |
| Storage Temperature | T _{STG} | -55 to 150 | °C |
| Power Dissipation (T _A = 25°C) ⁽⁴⁾ | P _D | 1.7 | W |
| Thermal Resistance | | | °C/W |
| Non-Exposed Pad | | | |
| Junction to Ambient | R _{θJA} | 74 | |
| Junction to Lead | R _{θJL} | 25 | |
| Exposed Pad | | | |
| Junction to Ambient | R _{θJA} | 71 | |
| Junction to Exposed Pad | R _{θJC} | 1.2 | |
| Peak Package Reflow Temperature During Reflow ^{(5), (6)} | T _{PPRT} | Note 6 | °C |

Notes

- Exceeding these limits may cause malfunction or permanent damage to the device.
- ESD data available upon request.
- ESD1 testing is performed in accordance with the Human Body Model (C_{ZAP} = 100 pF, R_{ZAP} = 1500 Ω), and ESD2 testing is performed in accordance with the Machine Model (C_{ZAP} = 200 pF, R_{ZAP} = 0 Ω).
- Maximum power dissipation at T_J = 150°C junction temperature with no heat sink used.
- Pin soldering temperature limit is for 10 seconds maximum duration. Not designed for immersion soldering. Exceeding these limits may cause malfunction or permanent damage to the device.
- Freescale's Package Reflow capability meets Pb-free requirements for JEDEC standard J-STD-020C. For Peak Package Reflow Temperature and Moisture Sensitivity Levels (MSL), Go to www.freescale.com, search by part number [e.g. remove prefixes/suffixes and enter the core ID to view all orderable parts. (i.e. MC33xxx enter 33xxx), and review parametrics.

STATIC ELECTRICAL CHARACTERISTICS

Table 4. Static Electrical Characteristics

Characteristics noted under conditions $3.1\text{ V} \leq V_{DD} \leq 5.25\text{ V}$, $8.0\text{ V} \leq V_{PWR} \leq 16\text{ V}$, $-40^\circ\text{C} \leq T_C \leq 125^\circ\text{C}$, unless otherwise noted. (7) Where applicable, typical values reflect the parameter's approximate average value with $V_{PWR} = 13\text{ V}$, $T_A = 25^\circ\text{C}$.

| Characteristic | Symbol | Min | Typ | Max | Unit |
|--|---|----------------|------|-------|------------------|
| POWER INPUT | | | | | |
| Supply Voltage | | | | | V |
| Supply Voltage Range Quasi-functional ⁽⁸⁾ | $V_{PWR(QF)}$ | 5.5 | – | 8.0 | |
| Fully Operational | $V_{PWR(FO)}$ | 8.0 | – | 26 | |
| Supply Voltage Range Quasi-functional ⁽⁸⁾ | $V_{PWR(QF)}$ | 26 | – | 38/40 | |
| Supply Current | | | | | mA |
| All Switches Open, Normal Mode, Tri-state Disabled | $I_{PWR(ON)}$ | – | 2.0 | 4.0 | |
| Sleep State Supply Current | | | | | μA |
| Scan Timer = 64 ms, Switches Open | $I_{PWR(SS)}$ | 40 | 70 | 100 | |
| Logic Supply Voltage | V_{DD} | 3.1 | – | 5.25 | V |
| Logic Supply Current | | | | | mA |
| All Switches Open, Normal mode | I_{DD} | – | 0.25 | 0.5 | |
| Sleep State Logic Supply Current | | | | | μA |
| Scan Timer = 64 ms, Switches Open | $I_{DD(SS)}$ | – | 10 | 20 | |
| SWITCH INPUT | | | | | |
| Pulse Wetting Current Switch-to-Battery (Current Sink) | I_{PULSE} | 12 | 15 | 18 | mA |
| Pulse Wetting Current Switch-to-Ground (Current Source) | I_{PULSE} | 12 | 16 | 18 | mA |
| Sustain Current Switch-to-Battery Input (Current Sink) | $I_{SUSTAIN}$ | 1.8 | 2.0 | 2.2 | mA |
| Sustain Current Switch-to-Ground Input (Current Source) | $I_{SUSTAIN}$ | 1.8 | 2.0 | 2.2 | mA |
| Sustain Current Matching Between Channels on Switch-to-Ground I/Os | I_{MATCH} | | | | % |
| | $\frac{I_{SUS(MAX)} - I_{SUS(MIN)}}{I_{SUS(MIN)}} \times 100$ | – | 2.0 | 4.0 | |
| Input Offset Current When Selected as Analog | I_{OFFSET} | -2.0 | 1.4 | 2.0 | μA |
| Input Offset Voltage When Selected as Analog | V_{OFFSET} | | | | mV |
| $V_{(SP\&SGINPUTS)}$ to AMUX Output | | -10 | 2.5 | 10 | |
| Analog Operational Amplifier Output Voltage | | | | | mV |
| Sink $250\mu\text{A}$ | V_{OL} | – | 10 | 30 | |
| Analog Operational Amplifier Output Voltage | | | | | V |
| Source $250\mu\text{A}$ | V_{OH} | $V_{DD} - 0.1$ | – | – | |
| Switch Detection Threshold | V_{TH} | 3.70 | 4.0 | 4.3 | V |
| Switch Input Voltage Range | | | | | V |
| 33972 | V_{IN} | -14 | – | 38 | |
| 33972A | | -14 | – | 40 | |
| Temperature Monitor ^{(9), (10)} | T_{LIM} | 155 | – | 185 | $^\circ\text{C}$ |
| Temperature Monitor Hysteresis ⁽¹⁰⁾ | $T_{LIM(HYS)}$ | 5.0 | 10 | 15 | $^\circ\text{C}$ |

Notes

- T_C is the T_{CASE} of the package
- Device operational. Table parameters may be out of specification.
- Thermal shutdown of 16 mA pull-up and pulldown current sources only. 2.0 mA current source/sink and all other functions remain active.
- This parameter is guaranteed by design but is not production tested.

Table 4. Static Electrical Characteristics (continued)

Characteristics noted under conditions $3.1\text{ V} \leq V_{DD} \leq 5.25\text{ V}$, $8.0\text{ V} \leq V_{PWR} \leq 16\text{ V}$, $-40^\circ\text{C} \leq T_C \leq 125^\circ\text{C}$, unless otherwise noted.(7) Where applicable, typical values reflect the parameter's approximate average value with $V_{PWR} = 13\text{ V}$, $T_A = 25^\circ\text{C}$.

| Characteristic | Symbol | Min | Typ | Max | Unit |
|--|---------------------------------|----------------|-----|----------|---------------|
| DIGITAL INTERFACE | | | | | |
| Input Logic Voltage Thresholds ⁽¹¹⁾ | $V_{INLOGIC}$ | 0.8 | – | 2.2 | V |
| SCLK, SI, Tri-state SO Input Current 0 V to V_{DD} | $I_{SCLK}, I_{SI}, I_{SO(TRI)}$ | -10 | – | 10 | μA |
| \overline{CS} Input Current $\overline{CS} = V_{DD}$ | $I_{\overline{CS}}$ | -10 | – | 10 | μA |
| \overline{CS} Pull-up Current $\overline{CS} = 0\text{ V}$ | $I_{\overline{CS}}$ | 30 | – | 100 | μA |
| SO High-state Output Voltage $I_{SO(HIGH)} = -200\ \mu\text{A}$ | $V_{SO(HIGH)}$ | $V_{DD} - 0.8$ | – | V_{DD} | V |
| SO Low-state Output Voltage $I_{SO(HIGH)} = 1.6\text{ mA}$ | $V_{SO(LOW)}$ | – | – | 0.4 | V |
| Input Capacitance on SCLK, SI, Tri-state SO ⁽¹²⁾ | C_{IN} | – | – | 20 | pF |
| \overline{INT} Internal Pull-up Current | – | 15 | 40 | 100 | μA |
| \overline{INT} Voltage $\overline{INT} = \text{Open Circuit}$ | $V_{\overline{INT}(HIGH)}$ | $V_{DD} - 0.5$ | – | V_{DD} | V |
| \overline{INT} Voltage $I_{\overline{INT}} = 1.0\text{ mA}$ | $V_{\overline{INT}(LOW)}$ | – | 0.2 | 0.4 | V |
| \overline{WAKE} Internal Pull-up Current | $I_{\overline{WAKE}(PU)}$ | 20 | 40 | 100 | μA |
| \overline{WAKE} Voltage $\overline{WAKE} = \text{Open Circuit}$ | $V_{\overline{WAKE}(HIGH)}$ | 4.0 | 4.3 | 5.3 | V |
| \overline{WAKE} Voltage $I_{\overline{WAKE}} = 1.0\text{ mA}$ | $V_{\overline{WAKE}(LOW)}$ | – | 0.2 | 0.4 | V |
| \overline{WAKE} Voltage Maximum Voltage Applied to \overline{WAKE} Through External Pull-up | $V_{\overline{WAKE}(MAX)}$ | – | – | 40 | V |

Notes

- Upper and lower logic threshold voltage levels apply to SI, \overline{CS} , and SCLK.
- This parameter is guaranteed by design but is not production tested.

DYNAMIC ELECTRICAL CHARACTERISTICS

Table 5. Dynamic Electrical Characteristics

Characteristics noted under conditions $3.1\text{ V} \leq V_{DD} \leq 5.25\text{ V}$, $8.0\text{ V} \leq V_{PWR} \leq 16\text{ V}$, $-40^{\circ}\text{C} \leq T_C \leq 125^{\circ}\text{C}$, unless otherwise noted. Where applicable, typical values reflect the parameter’s approximate average value with $V_{PWR} = 13\text{ V}$, $T_A = 25^{\circ}\text{C}$.

| Characteristic | Symbol | Min | Typ | Max | Unit |
|---|-------------------|-----|-----|-----|---------------|
| SWITCH INPUT | | | | | |
| Pulse Wetting Current Time | $t_{PULSE(ON)}$ | 15 | 16 | 20 | ms |
| Interrupt Delay Time Normal Mode | $t_{INT-DLY}$ | – | 5.0 | 16 | μs |
| Sleep Mode Switch Scan Time | t_{SCAN} | 100 | 200 | 300 | μs |
| Calibrated Scan Timer Accuracy Sleep Mode | $t_{SCAN\ TIMER}$ | – | – | 10 | % |
| Calibrated Interrupt Timer Accuracy Sleep Mode | $t_{INT\ TIMER}$ | – | – | 10 | % |

DIGITAL INTERFACE TIMING⁽¹³⁾

| | | | | | |
|---|----------------|-----|-----|----|---------------|
| Required Low-state Duration on V_{PWR} for Reset ⁽¹⁴⁾ $V_{PWR} \leq 0.2\text{ V}$ | t_{RESET} | – | – | 10 | μs |
| Falling Edge of \overline{CS} to Rising Edge of SCLK Required Setup Time | t_{LEAD} | 100 | – | – | ns |
| Falling Edge of SCLK to Rising Edge of \overline{CS} Required Setup Time | t_{LAG} | 50 | – | – | ns |
| SI to Falling Edge of SCLK Required Setup Time | $t_{SI(SU)}$ | 16 | – | – | ns |
| Falling Edge of SCLK to SI Required Hold Time | $t_{SI(HOLD)}$ | 20 | – | – | ns |
| SI, \overline{CS} , SCLK Signal Rise Time ⁽¹⁵⁾ | $t_{R(SI)}$ | – | 5.0 | – | ns |
| SI, \overline{CS} , SCLK Signal Fall Time ⁽¹⁵⁾ | $t_{F(SI)}$ | – | 5.0 | – | ns |
| Time from Falling Edge of \overline{CS} to SO Low-impedance ⁽¹⁶⁾ | $t_{SO(EN)}$ | – | – | 55 | ns |
| Time from Rising Edge of \overline{CS} to SO High-impedance ⁽¹⁷⁾ | $t_{SO(DIS)}$ | – | – | 55 | ns |
| Time from Rising Edge of SCLK to SO Data Valid ⁽¹⁸⁾ | t_{VALID} | – | 25 | 55 | ns |

Notes

13. These parameters are guaranteed by design. Production test equipment uses 4.16 MHz, 5.0 V SPI interface.
14. This parameter is guaranteed by design but not production tested.
15. Rise and Fall time of incoming SI, \overline{CS} , and SCLK signals suggested for design consideration to prevent the occurrence of double pulsing.
16. Time required for valid output status data to be available on SO pin.
17. Time required for output states data to be terminated at SO pin.
18. Time required to obtain valid data out from SO following the rise of SCLK with 200 pF load.

TIMING DIAGRAMS

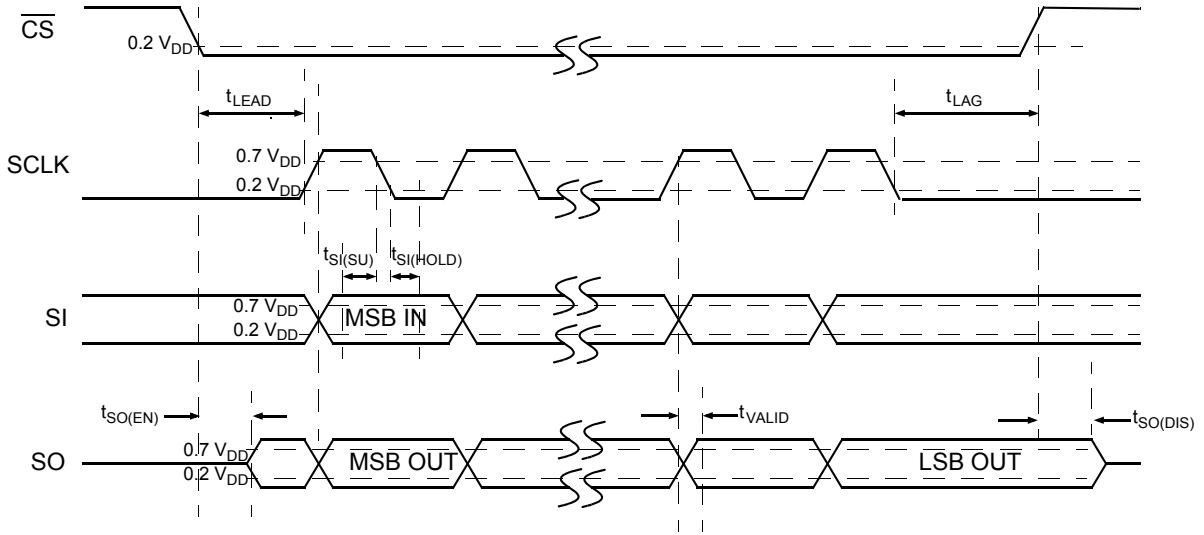

Figure 4. SPI Timing Characteristics

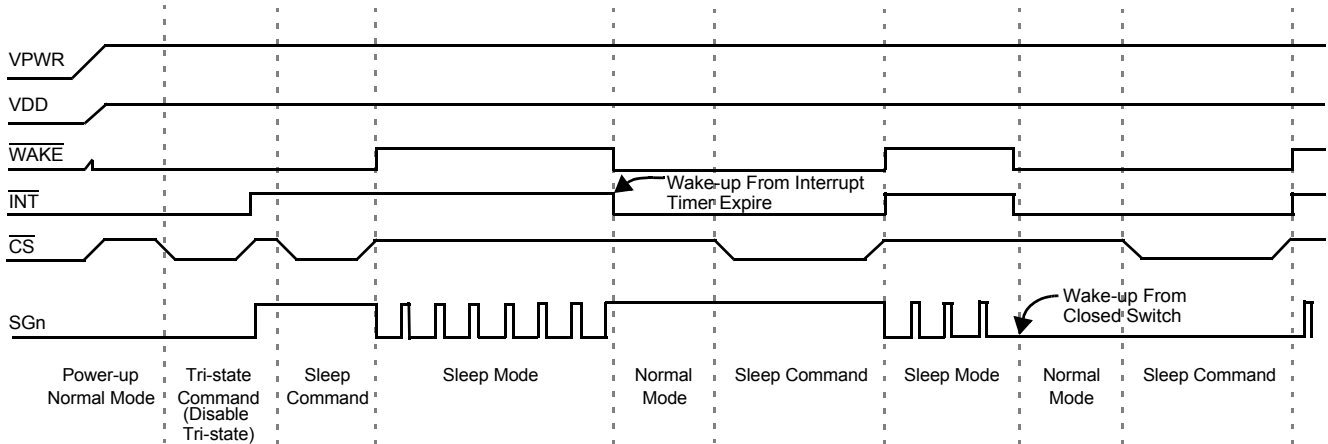

Figure 5. Sleep Mode to Normal Mode Operation

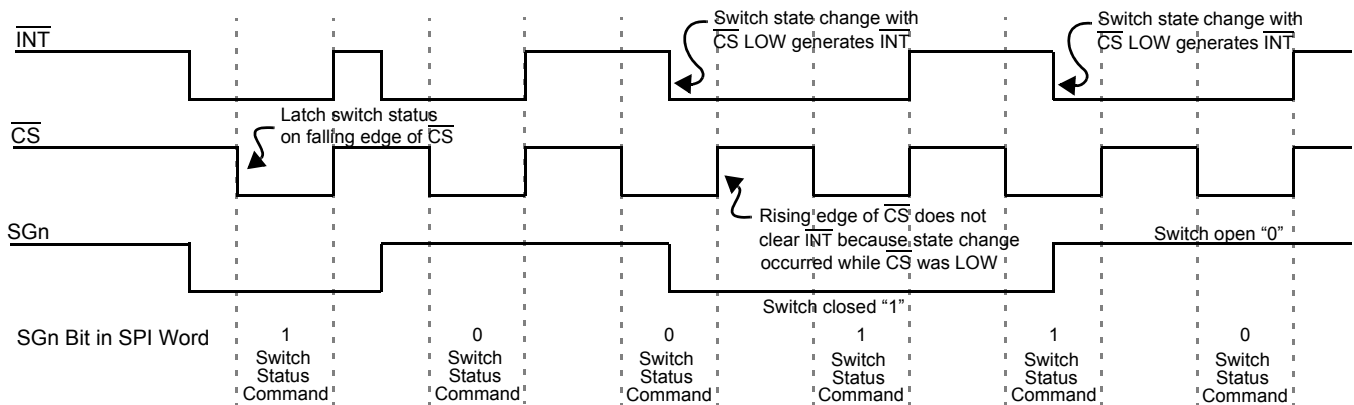

Figure 6. Normal Mode Interrupt Operation

FUNCTIONAL DESCRIPTION

INTRODUCTION

The 33972 device is an integrated circuit designed to provide systems with ultra-low quiescent sleep/wake-up modes, and a robust interface between switch contacts and a microprocessor. The 33972 replaces many of the discrete components required when interfacing to microprocessor-based systems, while providing switch ground offset protection, contact wetting current, and a system wake-up.

The 33972 features 8-programmable switch-to-ground or switch-to-battery inputs and 14 switch-to-ground inputs. All

switch inputs may be read as analog inputs through the analog multiplexer (AMUX). Other features include a programmable wake-up timer, programmable interrupt timer, programmable wake-up/interrupt bits, and programmable wetting current settings.

This device is designed primarily for automotive applications, but may be used in a variety of other applications such as computer, telecommunications, and industrial controls.

FUNCTIONAL PIN DESCRIPTION

CHIP SELECT (\overline{CS})

The system MCU selects the 33972 to receive communication using the chip select (\overline{CS}) pin. With the \overline{CS} in a logic LOW state, command words may be sent to the 33972 via the serial input (SI) pin, and switch status information can be received by the MCU via the serial output (SO) pin. The falling edge of \overline{CS} enables the SO output, latches the state of the \overline{INT} pin, and the state of the external switch inputs.

Rising edge of the \overline{CS} initiates the following operation:

1. Disables the SO driver (high-impedance)
2. \overline{INT} pin is reset to logic [1], except when additional switch changes occur during \overline{CS} LOW. (See [Figure 6](#) on page 9.)
3. Activates the received command word, allowing the 33972 to act upon new data from switch inputs.

To avoid any spurious data, it is essential the HIGH-to-LOW and LOW-to-HIGH transitions of the \overline{CS} signal occur only when SCLK is in a logic LOW state. A clean \overline{CS} is needed to ensure no incomplete SPI words are sent to the device. Internal to the 33972 device is an active pull-up to V_{DD} on \overline{CS} .

In Sleep mode, the negative edge of \overline{CS} (V_{DD} applied) will wake up the 33972 device. Data received from the device during \overline{CS} wake-up may not be accurate.

SYSTEM CLOCK (SCLK)

The system clock (SCLK) pin clocks the internal shift register of the 33972. The SI data is latched into the input shift register on the falling edge of SCLK signal. The SO pin shifts the switch status bits out on the rising edge of SCLK. The SO data is available for the MCU to read on the falling edge of SCLK. False clocking of the shift register must be avoided to ensure validity of data. It is essential the SCLK pin be in a logic LOW state whenever \overline{CS} makes any transition. For this reason, it is recommended, that the SCLK pin is commanded to a logic LOW state as long as the device is not accessed and \overline{CS} is in a logic HIGH state. When the \overline{CS} is in

a logic HIGH state, any signal on the SCLK and SI pins will be ignored and the SO pin is tri-state.

SPI SLAVE IN (SI)

The SI pin is used for serial instruction data input. SI information is latched into the input register on the falling edge of SCLK. A logic HIGH state present on SI will program a *one* in the command word on the rising edge of the \overline{CS} signal. To program a complete word, 24 bits of information must be entered into the device.

SPI SLAVE OUT (SO)

The SO pin is the output from the shift register. The SO pin remains tri-stated until the \overline{CS} pin transitions to a logic LOW state. All open switches are reported as zero, all closed switches are reported as one. The negative transition of \overline{CS} enables the SO driver.

The first positive transition of SCLK will make the status data bit 24 available on the SO pin. Each successive positive clock will make the next status data bit available for the MCU to read on the falling edge of SCLK. The SI/SO shifting of the data follows a first-in, first-out protocol, with both input and output words transferring the most significant bit (MSB) first.

INTERRUPT (\overline{INT})

The \overline{INT} pin is an interrupt output from the 33972 device. The \overline{INT} pin is an open-drain output with an internal pull-up to V_{DD} . In Normal mode, a switch state change will trigger the \overline{INT} pin (when enabled). The \overline{INT} pin and INT bit in the SPI register are latched on the falling edge of \overline{CS} . This permits the MCU to determine the origin of the interrupt. When two 33972 devices are used, only the device initiating the interrupt will have the INT bit set. The \overline{INT} pin is cleared on the rising edge of \overline{CS} . The \overline{INT} pin will not clear with rising edge of \overline{CS} if a switch contact change has occurred while \overline{CS} was LOW.

In a multiple 33972 device system with \overline{WAKE} HIGH and V_{DD} in (Sleep Mode), the falling edge of \overline{INT} will place all 33972s in Normal mode.

WAKE-UP ($\overline{\text{WAKE}}$)

The $\overline{\text{WAKE}}$ pin is an open-drain output and a wake-up input. The pin is designed to control a power supply Enable pin. In the Normal mode, the $\overline{\text{WAKE}}$ pin is LOW. In the Sleep mode, the $\overline{\text{WAKE}}$ pin is HIGH. The $\overline{\text{WAKE}}$ pin has a pull-up to the internal +5.0 V supply.

In Sleep mode with the $\overline{\text{WAKE}}$ pin HIGH, the falling edge of $\overline{\text{WAKE}}$ will place the 33972 in Normal mode. In Sleep mode with V_{DD} applied, the $\overline{\text{INT}}$ pin must be HIGH for negative edge of $\overline{\text{WAKE}}$ to wake up the device. If V_{DD} is not applied to the device in Sleep mode, $\overline{\text{INT}}$ does not affect WAKE operation.

BATTERY INPUT (VPWR)

The VPWR pin is battery input and Power-ON Reset to the 33972 IC. The VPWR pin requires external reverse battery and transient protection. Maximum input voltage on VPWR is 50 V. All wetting, sustain, and internal logic current is provided from the VPWR pin.

VOLTAGE DRAIN SUPPLY (VDD)

The VDD input pin is used to determine logic levels on the microprocessor interface (SPI) pins. Current from VDD is used to drive SO output and the pull-up current for $\overline{\text{CS}}$ and $\overline{\text{INT}}$ pins. VDD must be applied for wake-up from negative edge of $\overline{\text{CS}}$ or $\overline{\text{INT}}$.

GROUND (GND)

The GND pin provides ground for the IC as well as ground for inputs programmed as switch-to-battery inputs.

PROGRAMMABLE SWITCHES (SP0:SP7)

The 33972 device has 8 switch inputs capable of being programmed to read switch-to-ground or switch-to-battery contacts. The input is compared with a 4.0 V reference. When programmed to be switch-to-battery, voltages greater than 4.0 V are considered closed. Voltages less than 4.0 V are considered open. The opposite holds true when inputs are programmed as switch-to-ground. Programming features are defined in [Table 6](#) through [Table 11](#) in the [Functional Device Operation](#) section of this datasheet beginning on page [13](#). Voltages greater than the VPWR supply voltage will source current through the SP inputs to the VPWR pin. Transient battery voltages greater than 38/40 V must be clamped by an external device.

SWITCH-TO-GROUND INPUTS (SG0:SG13)

The SGn pins are switch-to-ground inputs only. The input is compared with a 4.0 V reference. Voltages greater than 4.0 V are considered open. Voltages less than 4.0 V are considered closed. Programming features are defined in [Table 6](#) through [Table 11](#) in the [Functional Device Operation](#) section of this datasheet beginning on page [13](#). Voltages greater than the VPWR supply voltage will source current through the SG inputs to the VPWR pin. Transient battery voltages greater than 40 V must be clamped by an external device.

FUNCTIONAL INTERNAL BLOCK DESCRIPTION

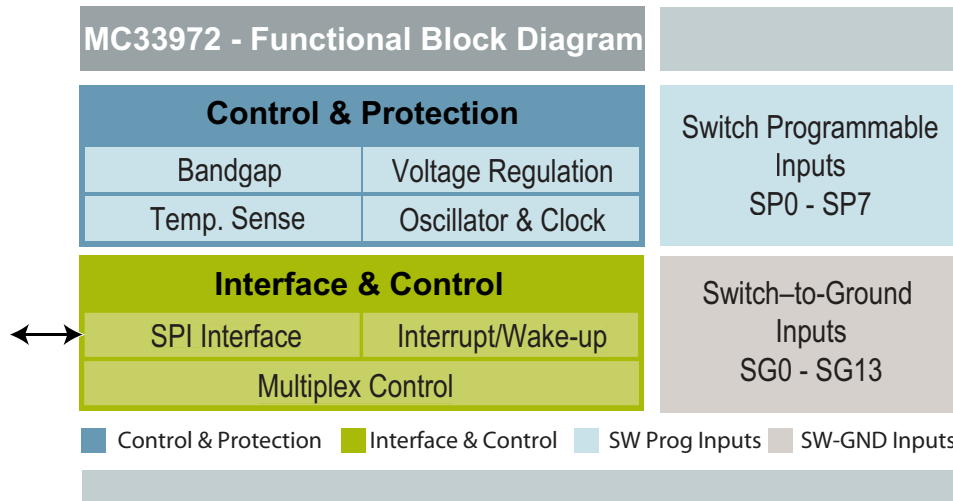

Figure 7. Functional Internal Block Description

CONTROL AND PROTECTION CIRCUITRY:

The 33972 is designed to operate from 5.5 V to 38/40 V on the VPWR terminal. Characteristics are provided from 8.0 to 28 V for the device. Switch contact currents and the internal logic supply are generated from the VPWR terminal. The VDD supply terminal is used to set the SPI communication voltage levels, current source for the SO driver, and pull-up current on INT and CS.

The on-chip voltage regulator and bandgap supplies the required voltages to the internal monitor circuitry. The temperature monitor is active in the Normal mode.

INTERFACE AND CONTROL:

The 33972 Multiple Switch Detection Interface with Suppressed Wake-up is designed to detect the closing and opening of up to 22 switch contacts. The switch status, either open or closed, is transferred to the microprocessor unit (MCU) through a serial peripheral interface (SPI).

The device also features a 22-to-1 analog multiplexer for reading inputs as analog. The 33972 device has two modes of operation, Normal and Sleep.

SWITCH PROGRAMMABLE INPUTS:

Programmable switch detection inputs. These 8 inputs can selectively detect switch closures to Ground or Battery. The 33972 device has 8 switch inputs capable of being programmed to read switch-to-ground or switch-to-battery contacts. The input is compared with a 4.0 V reference. When programmed to be switch-to-battery, voltages greater than 4.0 V are considered closed. Voltages less than 4.0 V are considered open. The opposite holds true when inputs are programmed as switch-to-ground.

SWITCH-TO-GROUND INPUTS:

Switch detection interface inputs. These 14 inputs can detect switch closures to ground only. The input is compared with a 4.0 V reference. Voltages greater than 4.0 V are considered open. Voltages less than 4.0 V are considered closed. Note: Each of these inputs may be used to supply current to sensors external to a module.

FUNCTIONAL DEVICE OPERATION

OPERATIONAL MODES

MCU INTERFACE DESCRIPTION

The 33972 device directly interfaces to a 3.3 or 5.0 V microcontroller unit (MCU). SPI serial clock frequencies up to 6.0 MHz may be used for programming and reading switch input status (production tested at 4.16 MHz). [Figure 8](#) illustrates the configuration between an MCU and one 33972.

Serial peripheral interface (SPI) data is sent to the 33972 device through the SI input pin. As data is being clocked into the SI pin, status information is being clocked out of the device by the SO output pin. The response to a SPI command will always return the switch status, interrupt flag, and thermal flag. Input switch states are latched into the SO register on the falling edge of the chip select (\overline{CS}) pin. Twenty-four bits are required to complete a transfer of information between the 33972 and the MCU.

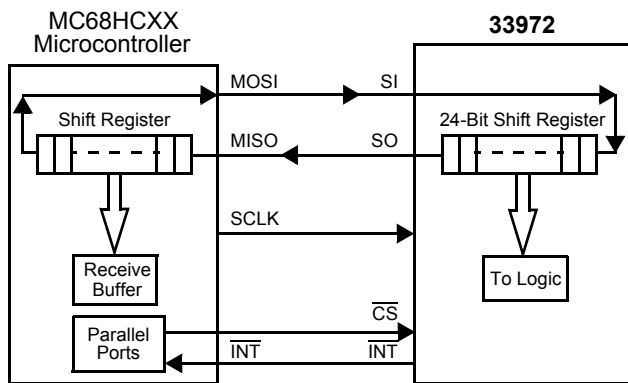

Figure 8. SPI Interface with Microprocessor

Two or more 33972 devices may be used in a module system. Multiple ICs may be SPI-configured in parallel or serial. [Figures 9](#) and [10](#) show the configurations. When using the serial configuration, 48-clock cycles are required to transfer data in/out of the ICs.

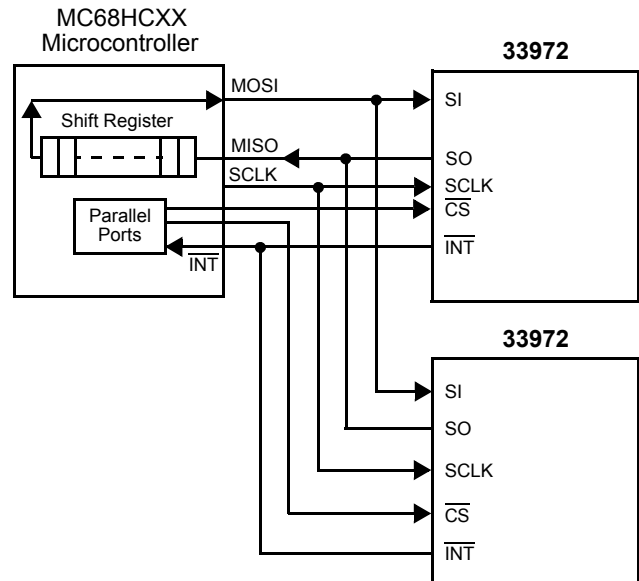

Figure 9. SPI Parallel Interface with Microprocessor

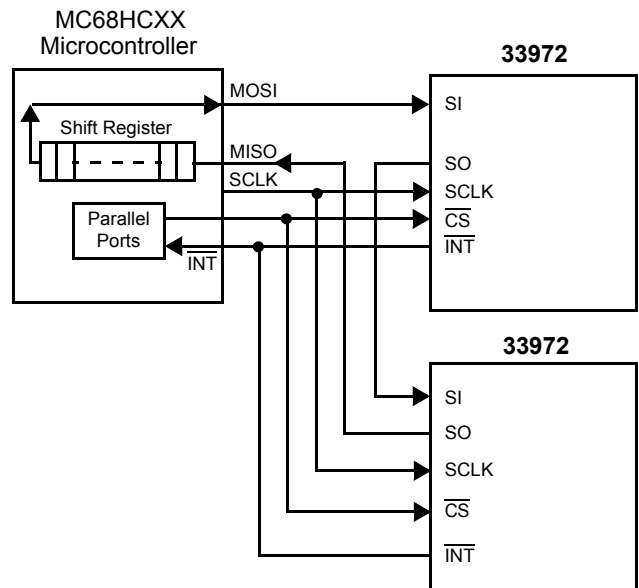

Figure 10. SPI Serial Interface with Microprocessor

POWER SUPPLY

The 33972 is designed to operate from 5.5 to 40 V on the VPWR pin. Characteristics are provided from 8.0 to 16 V for the device. Switch contact currents and the internal logic supply are generated from the VPWR pin. The VDD supply pin is used to set the SPI communication voltage levels, current source for the SO driver, and pull-up current on $\overline{\text{INT}}$ and $\overline{\text{CS}}$.

The VDD supply may be removed from the device to reduce quiescent current. If V_{DD} is removed while the device is in Normal mode, the device will remain in Normal mode. If V_{DD} is removed in Sleep mode, the device will remain in Sleep mode until a wake-up input is received ($\overline{\text{WAKE}}$ HIGH to LOW, switch input or interrupt timer expires).

Removing V_{DD} from the device disables SPI communication and will not allow the device to wake up from $\overline{\text{INT}}$ and $\overline{\text{CS}}$ pins.

POWER-ON RESET (POR)

Applying V_{PWR} to the device will cause a Power-ON Reset and place the device in Normal mode.

Default settings from Power-ON Reset via V_{PWR} or the Reset Command are as follows:

- Programmable switch – set to switch to battery
- All inputs set as wake-up
- Wetting current on (16 mA)
- Wetting current timer on (20 ms)
- All inputs tri-state
- Analog select 00000 (no input channel selected)

NORMAL AND SLEEP MODES

The 33972 has two operating modes, Normal mode and Sleep mode. A discussion on Normal mode begins below. A discussion on Sleep mode begins on page 19.

Normal Mode

Normal mode may be entered by the following events:

- Application of V_{PWR} to the IC
- Change-of-switch state (when enabled)

Table 6. Settings Command

| Settings Command | | | | | | | | Not used | | | | | | | | Battery/Ground Select | | | | | | | |
|------------------|----|----|----|----|----|----|----|----------|----|----|----|----|----|---|---|-----------------------|-----|-----|-----|-----|-----|-----|-----|
| 23 | 22 | 21 | 20 | 19 | 18 | 17 | 16 | 15 | 14 | 13 | 12 | 11 | 10 | 9 | 8 | 7 | 6 | 5 | 4 | 3 | 2 | 1 | 0 |
| 0 | 0 | 0 | 0 | 0 | 0 | 0 | 1 | X | X | X | X | X | X | X | X | sp7 | sp6 | sp5 | sp4 | sp3 | sp2 | sp1 | sp0 |

WAKE-UP/INTERRUPT REGISTER

The wake-up/interrupt register defines the inputs that are allowed to wake the 33972 from Sleep Mode or set the $\overline{\text{INT}}$ pin LOW in Normal mode. Programming the wake-up/interrupt bit to logic [0] will disable the specific input from generating an interrupt and will disable the specific input from

- Falling edge of $\overline{\text{WAKE}}$
- Falling edge of $\overline{\text{INT}}$ (with $V_{\text{DD}} = 5.0 \text{ V}$ and $\overline{\text{WAKE}}$ at Logic [1])
- Falling edge of $\overline{\text{CS}}$ (with $V_{\text{DD}} = 5.0 \text{ V}$)
- Interrupt timer expires

Only in Normal mode with V_{DD} applied can the registers of the 33972 be programmed through the SPI.

The registers that may be programmed in Normal mode are listed below. Further explanation of each register is provided in subsequent paragraphs.

- [Programmable Switch Register](#) (*Settings Command*)
- [Wake-Up/Interrupt Register](#) (*Wake-up/Interrupt Command*)
- [Wetting Current Register](#) (*Metallic Command*)
- [Wetting Current Timer Register](#) (*Wetting Current Timer Enable Command*)
- [Tri-State Register](#) (*Tri-state Command*)
- [Analog Select Register](#) (*Analog Command*)
- [Calibration of Timers](#) (*Calibration Command*)
- [Reset](#) (*Reset Command*)

Figure 6, page 9, is a graphical description of the device operation in Normal mode. Switch states are latched into the input register on the falling edge of $\overline{\text{CS}}$. The $\overline{\text{INT}}$ to the MCU is cleared on the rising edge of $\overline{\text{CS}}$. However, $\overline{\text{INT}}$ will not clear on rising edge of $\overline{\text{CS}}$ if a switch has closed during SPI communication ($\overline{\text{CS}}$ LOW). This prevents switch states from being missed by the MCU.

PROGRAMMABLE SWITCH REGISTER

Inputs SP0 to SP7 may be programmable for switch-to-battery or switch-to-ground. These inputs types are defined using the *settings command* (Table 6). To set an SPn input for switch-to-battery, a logic [1] for the appropriate bit must be set. To set an SPn input for switch-to-ground, a logic [0] for the appropriate bit must be set. The MCU may change or update the programmable switch register via software at any time in Normal mode. Regardless of the setting, when the SPn input switch is closed a logic [1] will be placed in the serial output response register (Table 17, page 19).

waking the IC in Sleep mode (Table 7). Programming the wake-up/interrupt bit to logic [1] will enable the specific input to generate an interrupt with switch change of state and will enable the specific input as wake-up. The MCU may change or update the wake-up/interrupt register via software at any time in Normal mode.

Table 7. Wake-up/Interrupt Command

| Wake-up/Interrupt Command | | | | | | | | Command Bits | | | | | | | | | | | | | | | |
|---------------------------|----|----|----|----|----|----|----|--------------|----|------|------|------|------|-----|-----|-----|-----|-----|-----|-----|-----|-----|-----|
| 23 | 22 | 21 | 20 | 19 | 18 | 17 | 16 | 15 | 14 | 13 | 12 | 11 | 10 | 9 | 8 | 7 | 6 | 5 | 4 | 3 | 2 | 1 | 0 |
| 0 | 0 | 0 | 0 | 0 | 0 | 1 | 0 | X | X | X | X | X | X | X | X | sp7 | sp6 | sp5 | sp4 | sp3 | sp2 | sp1 | sp0 |
| 0 | 0 | 0 | 0 | 0 | 0 | 1 | 1 | X | X | sg13 | sg12 | sg11 | sg10 | sg9 | sg8 | sg7 | sg6 | sg5 | sg4 | sg3 | sg2 | sg1 | sg0 |

WETTING CURRENT REGISTER

The 33972 has two levels of switch contact current, 16 and 2.0 mA (see Figure 11). The metallic command is used to set the switch contact current level (Table 8). Programming the metallic bit to logic [0] will set the switch wetting current to 2.0 mA. Programming the metallic bit to logic [1] will set the switch contact wetting current to 16 mA. The MCU may change or update the wetting current register via software at any time in Normal mode.

Wetting current is designed to provide higher levels of current during switch closure. The higher level of current is designed to keep switch contacts from building up oxides that form on the switch contact surface.

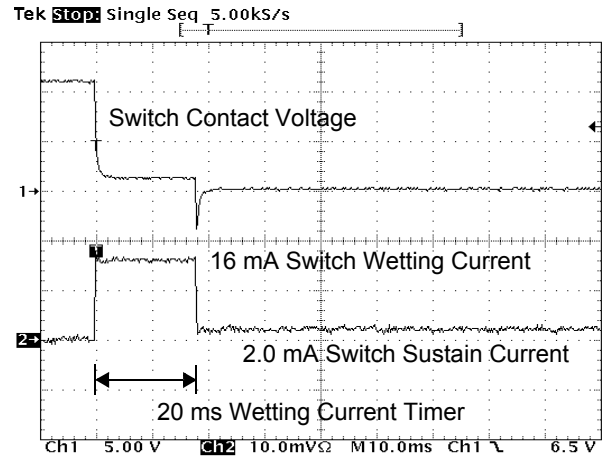

Figure 11. Contact Wetting and Sustain Current

Table 8. Metallic Command

| Metallic Command | | | | | | | | Command Bits | | | | | | | | | | | | | | | |
|------------------|----|----|----|----|----|----|----|--------------|----|------|------|------|------|-----|-----|-----|-----|-----|-----|-----|-----|-----|-----|
| 23 | 22 | 21 | 20 | 19 | 18 | 17 | 16 | 15 | 14 | 13 | 12 | 11 | 10 | 9 | 8 | 7 | 6 | 5 | 4 | 3 | 2 | 1 | 0 |
| 0 | 0 | 0 | 0 | 0 | 1 | 0 | 0 | X | X | X | X | X | X | X | X | sp7 | sp6 | sp5 | sp4 | sp3 | sp2 | sp1 | sp0 |
| 0 | 0 | 0 | 0 | 0 | 1 | 0 | 1 | X | X | sg13 | sg12 | sg11 | sg10 | sg9 | sg8 | sg7 | sg6 | sg5 | sg4 | sg3 | sg2 | sg1 | sg0 |

WETTING CURRENT TIMER REGISTER

Each switch input has a designated 20 ms timer. The timer starts when the specific switch input crosses the comparator threshold (4.0 V). When the 20 ms timer expires, the contact current is reduced from 16 to 2.0 mA. The wetting current timer may be disabled for a specific input. When the timer is disabled, 16 mA of current will continue to flow through the

closed switch contact. With multiple wetting current timers disabled, power dissipation for the IC must be considered.

The MCU may change or update the wetting current timer register via software at any time in Normal mode. This allows the MCU to control the amount of time wetting current is applied to the switch contact. Programming the wetting current timer bit to logic [0] will disable the wetting current timer. Programming the wetting current timer bit to logic [1] will enable the wetting current timer (Table 9).

Table 9. Wetting Current Timer Enable Command

| Wetting Current Timer Commands | | | | | | | | Command Bits | | | | | | | | | | | | | | | |
|--------------------------------|----|----|----|----|----|----|----|--------------|----|------|------|------|------|-----|-----|-----|-----|-----|-----|-----|-----|-----|-----|
| 23 | 22 | 21 | 20 | 19 | 18 | 17 | 16 | 15 | 14 | 13 | 12 | 11 | 10 | 9 | 8 | 7 | 6 | 5 | 4 | 3 | 2 | 1 | 0 |
| 0 | 0 | 0 | 0 | 0 | 1 | 1 | 1 | X | X | X | X | X | X | X | X | sp7 | sp6 | sp5 | sp4 | sp3 | sp2 | sp1 | sp0 |
| 0 | 0 | 0 | 0 | 1 | 0 | 0 | 0 | X | X | sg13 | sg12 | sg11 | sg10 | sg9 | sg8 | sg7 | sg6 | sg5 | sg4 | sg3 | sg2 | sg1 | sg0 |

TRI-STATE REGISTER

The tri-state command is used to set the SPn or SGn input node as high-impedance (Table 10). By setting the tri-state register bit to logic [1], the input will be high-impedance regardless of the metallic command setting. The comparator

on each input remains active. This command allows the use of each input as a comparator with a 4.0 V threshold. The MCU may change or update the tri-state register via software at any time in Normal mode.

Table 10. Tri-State Command

| Tri-State Commands | | | | | | | | Command Bits | | | | | | | | | | | | | | | |
|--------------------|----|----|----|----|----|----|----|--------------|----|------|------|------|------|-----|-----|-----|-----|-----|-----|-----|-----|-----|-----|
| 23 | 22 | 21 | 20 | 19 | 18 | 17 | 16 | 15 | 14 | 13 | 12 | 11 | 10 | 9 | 8 | 7 | 6 | 5 | 4 | 3 | 2 | 1 | 0 |
| 0 | 0 | 0 | 0 | 1 | 0 | 0 | 1 | X | X | X | X | X | X | X | X | sp7 | sp6 | sp5 | sp4 | sp3 | sp2 | sp1 | sp0 |
| 0 | 0 | 0 | 0 | 1 | 0 | 1 | 0 | X | X | sg13 | sg12 | sg11 | sg10 | sg9 | sg8 | sg7 | sg6 | sg5 | sg4 | sg3 | sg2 | sg1 | sg0 |

ANALOG SELECT REGISTER

The analog voltage on switch inputs may be read by the MCU using the analog command (Table 11). Internal to the IC is a 22-to-1 analog multiplexer. The voltage present on the selected input pin is buffered and made available on the AMUX output pin. The AMUX output pin is clamped to a maximum of VDD volts regardless of the higher voltages present on the input pin. After an input has been selected as the analog, the corresponding bit in the next SO data stream will be logic [0]. When selecting a channel to be read as analog, the user must also set the desired current (16 mA, 2.0 mA, or high-impedance). Setting bit 6 and bit 5 to 0,0

selects the input as high-impedance. Setting bit 6 and bit 5 to 0,1 selects 2.0 mA, and 1,0 selects 16 mA. Setting bit 6 and bit 5 to 1,1 in the analog select register is not allowed and will place the input as an analog input with high-impedance.

Analog currents set by the analog command are pull-up currents for all SGn and SPn inputs (Table 11). The analog command does not allow pull-down currents on the SPn inputs. Setting the current to 16 or 2.0 mA may be useful for reading sensor inputs. Further information is provided in the Typical Applications section of this datasheet beginning on page 21. The MCU may change or update the analog select register via software at any time in Normal mode.

Table 11. Analog Command

| Analog Command | | | | | | | | Not used | | | | | | | | Current Select | | Analog Channel Select | | | | | |
|----------------|----|----|----|----|----|----|----|----------|----|----|----|----|----|---|---|----------------|-------|-----------------------|---|---|---|---|---|
| 23 | 22 | 21 | 20 | 19 | 18 | 17 | 16 | 15 | 14 | 13 | 12 | 11 | 10 | 9 | 8 | 7 | 6 | 5 | 4 | 3 | 2 | 1 | 0 |
| 0 | 0 | 0 | 0 | 0 | 1 | 1 | 0 | X | X | X | X | X | X | X | X | X | 16 mA | 2.0 mA | 0 | 0 | 0 | 0 | 0 |

Table 12. Analog Channel

| Bits 43210 | Analog Channel Select |
|------------|-----------------------|
| 00000 | No Input Selected |
| 00001 | SG0 |
| 00010 | SG1 |
| 00011 | SG2 |
| 00100 | SG3 |
| 00101 | SG4 |
| 00110 | SG5 |
| 00111 | SG6 |
| 01000 | SG7 |
| 01001 | SG8 |
| 01010 | SG9 |
| 01011 | SG10 |
| 01100 | SG11 |
| 01101 | SG12 |
| 01110 | SG13 |
| 01111 | SP0 |
| 10000 | SP1 |
| 10001 | SP2 |
| 10010 | SP3 |
| 10011 | SP4 |
| 10100 | SP5 |
| 10101 | SP6 |
| 10110 | SP7 |

CALIBRATION OF TIMERS

In cases where an accurate time base is required, the user may calibrate the internal timers using the calibration command (Table 13). After the 33972 device receives the calibration command, the device expects 512 μ s logic [0] calibration pulse on the \overline{CS} pin. The pulse is used to calibrate the internal clock. No other SPI pins should transition during

this 512 μ s calibration pulse. Because the oscillator frequency changes with temperature, calibration is required for an accurate time base. Calibrating the timers has no affect on the quiescent current measurement. The calibration command simply makes the time base more accurate. The calibration command may be used to update the device on a periodic basis.

Table 13. Calibration Command

| Calibration Command | | | | | | | | Command Bits | | | | | | | | | | | | | | | |
|---------------------|----|----|----|----|----|----|----|--------------|----|----|----|----|----|---|---|---|---|---|---|---|---|---|---|
| 23 | 22 | 21 | 20 | 19 | 18 | 17 | 16 | 15 | 14 | 13 | 12 | 11 | 10 | 9 | 8 | 7 | 6 | 5 | 4 | 3 | 2 | 1 | 0 |
| 0 | 0 | 0 | 0 | 1 | 0 | 1 | 1 | X | X | X | X | X | X | X | X | X | X | X | X | X | X | X | X |

RESET

The reset command resets all registers to Power-ON Reset (POR) state. Refer to [Table 15](#), page [18](#), for POR

states or the paragraph entitled [Power-ON Reset \(POR\)](#) on page [14](#) of this datasheet.

Table 14. Reset Command

| Reset Command | | | | | | | | Command Bits | | | | | | | | | | | | | | | |
|---------------|----|----|----|----|----|----|----|--------------|----|----|----|----|----|---|---|---|---|---|---|---|---|---|---|
| 23 | 22 | 21 | 20 | 19 | 18 | 17 | 16 | 15 | 14 | 13 | 12 | 11 | 10 | 9 | 8 | 7 | 6 | 5 | 4 | 3 | 2 | 1 | 0 |
| 0 | 1 | 1 | 1 | 1 | 1 | 1 | 1 | X | X | X | X | X | X | X | X | X | X | X | X | X | X | X | X |

SPI COMMAND SUMMARY

[Table 15](#) below provides a comprehensive list of SPI commands recognized by the 33972 and the reset state of each register. [Table 16](#) and [Table 17](#) contain the serial

output (SO) data for input voltages greater or less than the threshold level. Open switches are always indicated with a logic [0], closed switches are indicated with logic [1].

Table 15. SPI Command Summary

| | MSB | | | | | | | | Command Bits | | | | | | | | Setting Bits | | | | | | | | LSB | |
|---|-------------|------------|-----|-----|-----|-----|-----|-----|--------------|-----|------|------|------|------|-----|-----|--------------|--------------|--------------|--------------|---------------|---------------|---------------|---------------|-----|--|
| | 23 | 22 | 21 | 20 | 19 | 18 | 17 | 16 | 15 | 14 | 13 | 12 | 11 | 10 | 9 | 8 | 7 | 6 | 5 | 4 | 3 | 2 | 1 | 0 | | |
| Switch Status Command | 0 | 0 | 0 | 0 | 0 | 0 | 0 | 0 | 0 | X | X | X | X | X | X | X | X | X | X | X | X | X | X | X | | |
| Settings Command Bat=1, Gnd=0 (Default state = 1) | 0 | 0 | 0 | 0 | 0 | 0 | 0 | 0 | 1 | X | X | X | X | X | X | X | SP7 | SP6 | SP5 | SP4 | SP3 | SP2 | SP1 | SP0 | | |
| Wake-Up/Interrupt Bit Wake-Up=1 Non-Wake-Up=0 (Default state = 1) | 0 | 0 | 0 | 0 | 0 | 0 | 1 | 0 | X | X | X | X | X | X | X | X | SP7 | SP6 | SP5 | SP4 | SP3 | SP2 | SP1 | SP0 | | |
| Metallic Command Metallic = 1 Non-metallic = 0 (Default state = 1) | 0 | 0 | 0 | 0 | 0 | 1 | 0 | 0 | X | X | X | X | X | X | X | X | SP7 | SP6 | SP5 | SP4 | SP3 | SP2 | SP1 | SP0 | | |
| Analog Command | 0 | 0 | 0 | 0 | 0 | 1 | 1 | 0 | X | X | X | X | X | X | X | X | X | 16mA 0 | 2.0mA 0 | 0 | 0 | 0 | 0 | 0 | | |
| Wetting Current Timer Enable Command Timer ON = 1 Timer OFF = 0 (Default state = 1) | 0 | 0 | 0 | 0 | 0 | 1 | 1 | 1 | X | X | X | X | X | X | X | X | SP7 | SP6 | SP5 | SP4 | SP3 | SP2 | SP1 | SP0 | | |
| Tri-State Command Input Tri-State=1 Input Active = 0 (Default state = 1) | 0 | 0 | 0 | 0 | 1 | 0 | 0 | 1 | X | X | X | X | X | X | X | X | SP7 | SP6 | SP5 | SP4 | SP3 | SP2 | SP1 | SP0 | | |
| Calibration Command (Default state – uncalibrated) | 0 | 0 | 0 | 0 | 1 | 0 | 1 | 1 | X | X | X | X | X | X | X | X | X | X | X | X | X | X | X | X | | |
| Sleep Command (Refer to Sleep Mode on page 19.) | 0 | 0 | 0 | 0 | 1 | 1 | 0 | 0 | X | X | X | X | X | X | X | X | X | int timer | int timer | int timer | scan timer | scan timer | scan timer | scan timer | | |
| Reset Command | 0 | 1 | 1 | 1 | 1 | 1 | 1 | 1 | X | X | X | X | X | X | X | X | X | X | X | X | X | X | X | X | | |
| SO Response Will Always Send | them fig | int fig | SP7 | SP6 | SP5 | SP4 | SP3 | SP2 | SP1 | SP0 | SG13 | SG12 | SG11 | SG10 | SG9 | SG8 | SG7 | SG6 | SG5 | SG4 | SG3 | SG2 | SG1 | SG0 | | |

Table 16. Serial Output (SO) Bit Data

| Type of Input | Input Programmed | Voltage on Input Pin | SO SPI Bit |
|---------------|-------------------|----------------------|------------|
| SP | Switch to Ground | SPn < 4.0V | 1 |
| | Switch to Ground | SPn > 4.0V | 0 |
| | Switch to Battery | SPn < 4.0V | 0 |
| | Switch to Battery | SPn > 4.0V | 1 |
| SG | N/A | SGn < 4.0V | 1 |
| | N/A | SGn > 4.0V | 0 |

Table 17. Serial Output (SO) Response Register

| SO Response Will Always Send | them flg | int flg | SP7 | SP6 | SP5 | SP4 | SP3 | SP2 | SP1 | SP0 | SG13 | SG12 | SG11 | SG10 | SG9 | SG8 | SG7 | SG6 | SG5 | SG4 | SG3 | SG2 | SG1 | SG0 |
|------------------------------|----------|---------|-----|-----|-----|-----|-----|-----|-----|-----|------|------|------|------|-----|-----|-----|-----|-----|-----|-----|-----|-----|-----|
| | | | | | | | | | | | | | | | | | | | | | | | | |

EXAMPLE OF NORMAL MODE OPERATION

The operation of the device in Normal mode is defined by the states of the programmable internal control registers. A typical application may have the following settings:

- Programmable switch – set to switch-to-ground
- All inputs set as wake-up
- Wetting current on (16 mA)
- Wetting current timer on (20 ms)
- All inputs tri-state-disabled (comparator is active)
- Analog select 00000 (no input channel selected)

With the device programmed as above, an interrupt will be generated with each switch contact change of state (open-to-close or close-to-open) and 16 mA of contact wetting current will be source for 20 ms. The $\overline{\text{INT}}$ pin will remain LOW until switch status is acknowledged by the microprocessor. It is critical to understand $\overline{\text{INT}}$ will not be cleared on the rising edge of $\overline{\text{CS}}$ if a switch closure occurs while $\overline{\text{CS}}$ is LOW. The maximum duration a switch state change can exist without acknowledgement depends on the software response time to the interrupt. [Figure 6](#), page 9, shows the interaction between changing input states and the $\overline{\text{INT}}$ and $\overline{\text{CS}}$ pins.

If desired the user may disable interrupts (wake up/ interrupt command) from the 33972 device and read the switch states on a periodic basis. Switch activation and deactivation faster than the MCU read rate will not be acknowledged.

The 33972 device will exit the Normal mode and enter the Sleep mode only with a valid sleep command.

SLEEP MODE

Sleep mode is used to reduce system quiescent currents. Sleep mode may be entered only by sending the sleep command. All register settings programmed in Normal mode will be maintained in Sleep mode.

The 33972 will exit Sleep mode and enter Normal mode when any of the following events occur:

- Input switch change of state (when enabled)
- Interrupt timer expire
- Falling edge of $\overline{\text{WAKE}}$
- Falling edge of $\overline{\text{INT}}$ (with $V_{\text{DD}} = 5.0 \text{ V}$ and $\overline{\text{WAKE}}$ at Logic [1])
- Falling edge of $\overline{\text{CS}}$ (with $V_{\text{DD}} = 5.0 \text{ V}$)
- Power-ON Reset (POR)

The V_{DD} supply may be removed from the device during Sleep mode. However removing V_{DD} from the device in Sleep mode will disable a wake-up from falling edge of $\overline{\text{INT}}$ and $\overline{\text{CS}}$.

Note In cases where $\overline{\text{CS}}$ is used to wake the device, the first SO data message is not valid.

The sleep command contains settings for two programmable timers for Sleep mode, the interrupt timer and the scan timer, as shown in [Table 18](#) The interrupt timer is used as a periodic wake-up timer. When the timer expires, an interrupt is generated and the device enters Normal mode.

Note The interrupt timer in the 33972 device may be disabled by programming the interrupt bits to logic [1 1 1].

[Table 19](#) shows the programmable settings of the Interrupt timer.

Table 18. Sleep Command

| Sleep Command | | | | | | | | Command Bits | | | | | | | | | | | | | | | |
|---------------|----|----|----|----|----|----|----|--------------|----|----|----|----|----|---|---|---|---|-----------|-----------|-----------|------------|------------|------------|
| 23 | 22 | 21 | 20 | 19 | 18 | 17 | 16 | 15 | 14 | 13 | 12 | 11 | 10 | 9 | 8 | 7 | 6 | 5 | 4 | 3 | 2 | 1 | 0 |
| 0 | 0 | 0 | 0 | 1 | 1 | 0 | 0 | X | X | X | X | X | X | X | X | X | X | int timer | int timer | int timer | scan timer | scan timer | scan timer |

Table 19. Interrupt Timer

| Bits 543 | Interrupt Period |
|----------|----------------------|
| 000 | 32 ms |
| 001 | 64 ms |
| 010 | 128 ms |
| 011 | 256 ms |
| 100 | 512 ms |
| 101 | 1.024 s |
| 110 | 2.048 s |
| 111 | No interrupt wake-up |

The scan timer sets the polling period between input switch reads in Sleep mode. The period is set in the sleep command and may be set to 000 (no period) to 111 (64 ms). In Sleep mode when the scan timer expires, inputs will behave as programmed prior to sleep command. The 33972 will wake up for approximately 125 μ s and read the switch inputs. At the end of the 125 μ s, the input switch states are compared with the switch state prior to sleep command. When switch state changes are detected, an interrupt is generated (when enabled; refer to wake-up/interrupt command description on page 15), and the device enters Normal mode. Without switch state changes, the 33972 will reset the scan timer, inputs become tri-state, and the Sleep mode continues until the scan timer expires again.

Table 20 shows the programmable settings of the Scan timer.

Table 20. Scan Timer

| Bits 210 | Scan Period |
|----------|-------------|
| 000 | No Scan |
| 001 | 1.0 ms |
| 010 | 2.0 ms |
| 011 | 4.0 ms |
| 100 | 8.0 ms |
| 101 | 16 ms |
| 110 | 32 ms |
| 111 | 64 ms |

Note The interrupt and scan timers are disabled in the Normal Mode.

Figure 5, page 9, is a graphical description of how the 33972 device exits Sleep mode and enters Normal mode. Notice that the device will exit Sleep mode when the interrupt timer expires or when a switch change of state occurs. The falling edge of INT triggers the MCU to wake from Sleep state. Figure 12 illustrates the current consumed during Sleep mode. During the 125 μ s, the device is fully active and switch states are read. The quiescent current is calculated by integrating the normal running current over scan period plus approximately 60 μ A.

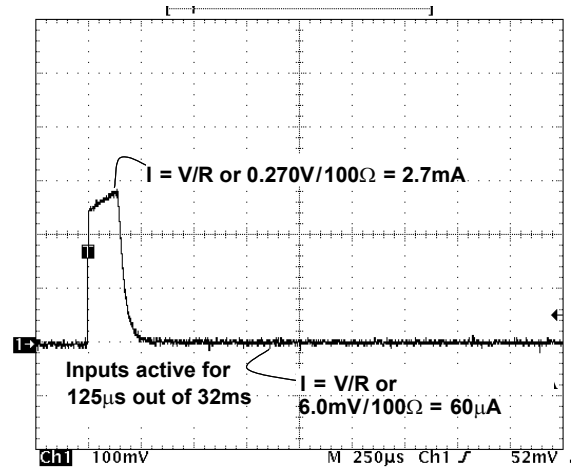

Figure 12. Sleep Current Waveform

TEMPERATURE MONITOR

With multiple switch inputs closed and the device programmed with the wetting current timers disabled, considerable power will be dissipated by the IC. For this reason, temperature monitoring has been implemented. The temperature monitor is active in the Normal mode only. When the IC temperature is above the thermal limit, the temperature monitor will do all of the following:

- Generate an interrupt.
- Force all 16 mA pull-up and pull-down current sources to revert to 2.0 mA current sources.
- Maintain the 2.0 mA current source and all other functionality.
- Set the thermal flag bit in the SPI output register.

The thermal flag bit in the SPI word will be cleared on rising edge of \overline{CS} provided the die temperature has cooled below the thermal limit. When die temperature has cooled below thermal limit, the device will resume previously programmed settings.

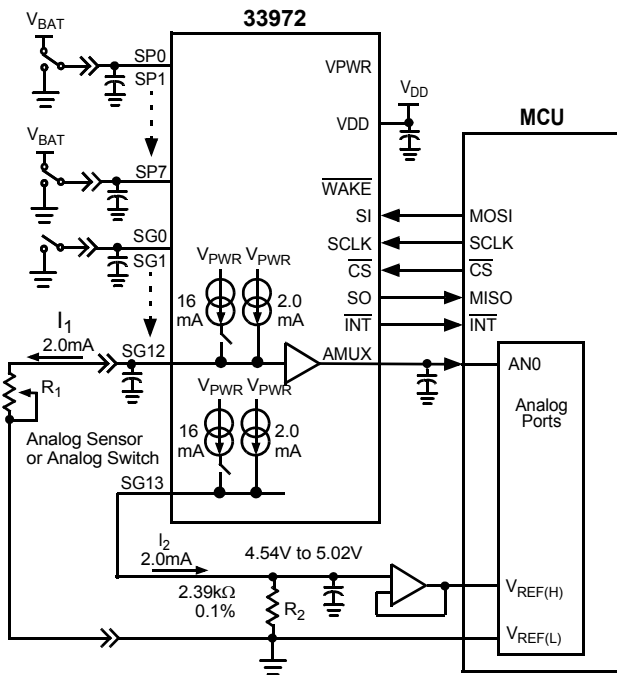

Figure 14. Analog Ratiometric Conversion

To read a potentiometer sensor, the wiper should be grounded and brought back to the module ground, as illustrated in Figure 14. With the wiper changing the impedance of the sensor, the analog voltage on the input will represent the position of the sensor.

Using the Analog feature to provide 2.0 mA of pull-up current to an analog sensor may induce error due to the accuracy of the current source. For this reason, a ratiometric conversion must be considered. Using two current sources (one for the sensor and one to set the reference voltage to the A/D converter) will yield a maximum error (owing to the 33972) of 4%.

Higher accuracy may be achieved through module level calibration. In this example, we use the resistor values from Figure 14 and assume the current sources are 4% from each other. The user may use the module end-of-line tester to calculate the error in the A/D conversion. By placing a 2.0 kΩ, 0.1% resistor in the end-of-line test equipment and assuming a perfect 2.0 mA current source from the 33972, a calculated A/D conversion may be obtained. Using the equation yields the following:

$$ADC = \frac{I_1 \times R_1}{I_2 \times R_2} \times 255$$

$$ADC = \frac{2.0\text{mA} \times 2.0\text{k}\Omega}{2.0\text{mA} \times 2.39\text{k}\Omega} \times 255$$

$$ADC = 213 \text{ counts}$$

The ADC value of 213 counts is the value with 0% error (neglecting the resistor tolerance and AMUX input offset voltage). Now we can calculate the count value induced by the mismatch in current sources. From a sample device the maximum current source was measured at 2.05 mA and minimum current source was measured at 1.99 mA. This yields 3% error in A/D conversion. The A/D measurement will be as follows:

$$ADC = \frac{1.99\text{mA} \times 2.0\text{k}\Omega}{2.05\text{mA} \times 2.39\text{k}\Omega} \times 255$$

$$ADC = 207 \text{ counts}$$

This A/D conversion is 3% low in value. The error correction factor of 1.03 may be used to correct the value:

$$ADC = 207 \text{ counts} \times 1.03$$

$$ADC = 213 \text{ counts}$$

An error correction factor may then be stored in E² memory and used in the A/D calculation for the specific input. Each input used as analog measurement will have a dedicated calibrated error correction factor.

POWER MOSFET/LED DRIVER AND MONITOR

Because of the flexible programming of the 33972 device, it may be used to drive small loads like LEDs or MOSFET gates. It was specifically designed to power up in the Normal mode with the inputs tri-state. This was done to ensure the LEDs or MOSFETs connected to the 33972 power up in the off-state. The switch programmable inputs (SP0–SP7) have a source-and-sink capability, providing effective MOSFET gate control. To complete the circuit, a pull-down resistor should be used to keep the gate from floating during the Sleep modes. Figure 15, page 23, shows an application where the SG0 input is used to monitor the drain-to-source voltage of the external MOSFET. The 1.5 kΩ resistor is used to set the drain-to-source trip voltage. With the 2.0 mA current source enabled, an interrupt will be generated when the drain-to-source voltage is approximately 1.0 V.

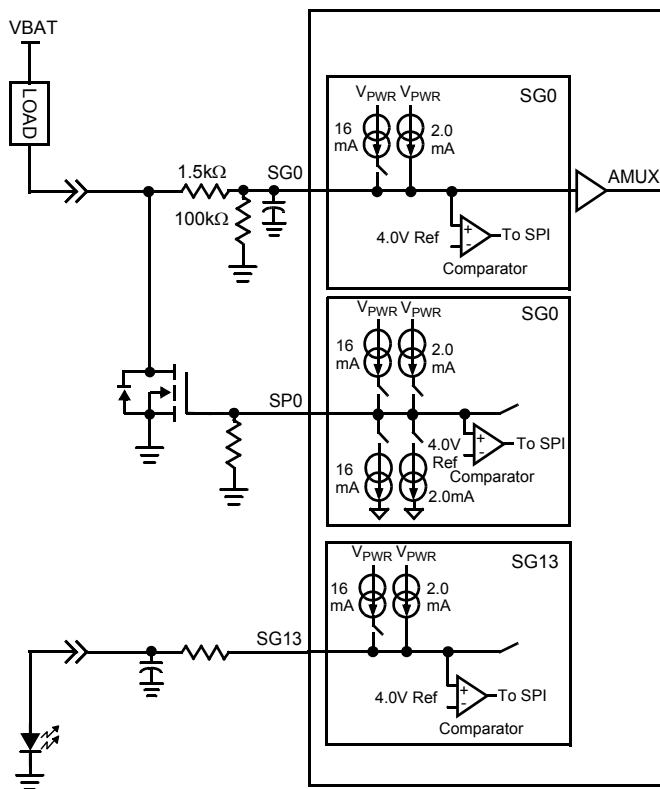

Figure 15. MOSFET or LED Driver Output

The sequence of commands (from Normal mode with inputs tri-state) required to set up the device to drive a MOSFET are as follows:

- wetting current timer enable command –Disable SPn wetting current timer (refer to [Table 9](#), page 15).
- metallic command –Set SPn to 16 or 2.0 mA gate drive current (refer to [Table 8](#), page 15).
- settings command –Set SPn as switch-to-battery (refer to [Table 6](#), page 14).
- tri-state command –Disable tri-state for SPn (refer to [Table 10](#), page 16).

After the tri-state command has been sent (tri-state disable), the MOSFET gate will be pulled to ground. From this point forward the MOSFET may be turned on and off by sending the settings command:

- settings command –SPn as switch-to-ground (MOSFET ON).
- settings command –SPn as switch-to-battery (MOSFET OFF).

Monitoring of the MOSFET drain in the OFF state provides open load detection. This is done by using an SGn input comparator. With the SGn input in tri-state, the load will pull up the SGn input to battery. With open load the SGn pin is pulled down to ground through an external resistor. The open load is indicated by a logic [1] in the SO data bit.

The analog command may be used to monitor the drain voltage in the MOSFET ON state. By sourcing 2.0 mA of

current to the 1.5 kΩ resistor, the analog voltage on the SGn pin will be approximately:

$$V_{SGn} = I_{SGn} \times 1.5k\Omega + V_{DS}$$

As the voltage on the drain of the MOSFET increases, so does the voltage on the SGn pin. With the SGn pin selected as analog, the MCU may perform the A/D conversion.

Using this method for controlling unclamped inductive loads is not recommended. Inductive flyback voltages greater than V_{PWR} may damage the IC.

The SP0:SP7 pins of this device may also be used to send signals from one module to another. Operation is similar to the gate control of a MOSFET.

- For LED applications a resistor in series with the LED is recommended but not required. The switch-to-ground inputs are recommended for LED application. To drive the LED use the following commands:
- wetting current timer enable command –Disable SGn wetting current timer.
- metallic command –Set SGn to 16 mA.

From this point forward the LED may be turned on and off using the tri-state command:

- tri-state command –Disable tri-state for SGn (LED ON).
- tri-state command –Enable tri-state for SGn (LED OFF).

These parameters are easily programmed via SPI commands in Normal mode.

MULTIPLE 33972 DEVICES IN A MODULE SYSTEM

Connecting power to the 33972 and the MCU for Sleep mode operation may be done in several ways. [Table 21](#) shows several system configurations for power between the MCU and the 33972 and their specific requirements for functionality.

Table 21. Sleep Mode Power Supply

| MCU V_{DD} | 33972 V_{DD} | Comments |
|--------------|----------------|---|
| 5.0 V | 5.0 V | All wake-up conditions apply. (Refer to Sleep Mode , page 19.) |
| 5.0 V | 0 V | SPI wake-up is not possible. |
| 0 V | 5.0 V | Sleep mode not possible. Current from \overline{CS} pull-up will flow through MCU to V_{DD} that has been switched off. Negative edge of \overline{CS} will put 33972 in Normal mode. |
| 0 V | 0 V | SPI wake-up is not possible. |

Multiple 33972 devices may be used in a module system. SPI control may be done in parallel or serial. However when parallel mode is used, each device is addressed independently (refer to [MCU Interface Description](#), page 13). Therefore when sending the sleep command, one device will enter sleep before the other. For multiple devices in a system, it is recommended that the devices are controlled in serial (S0

from first device is connected to SI of second device). With two devices, 48 clock pulses are required to shift data in. When the $\overline{\text{WAKE}}$ feature is used to enable the power supply, both $\overline{\text{WAKE}}$ pins should be connected to the enable pin on the power supply. The $\overline{\text{INT}}$ pins may be connected to one interrupt pin on the MCU or may have their own dedicated interrupt to the MCU.

The transition from Normal to Sleep mode is done by sending the sleep command. With the devices connected in serial and the sleep command sent, both will enter Sleep mode on the rising edge of $\overline{\text{CS}}$. When Sleep mode is entered, the $\overline{\text{WAKE}}$ pin will be logic [1]. If either device wakes up, the $\overline{\text{WAKE}}$ pin will transition LOW, waking the other device.

A condition exists where the MCU is sending the sleep command (CS logic [0]) and a switch input changes state. With this event the device that detects this input will not transition to Sleep mode, while the second device will enter Sleep mode. In this case two switch status commands must be sent to receive accurate switch status data. The first switch status command will wake the device in Sleep mode. Switch status data may not be valid from the first switch status command because of the time required for the input voltage to rise above the 4.0 V input comparator threshold. This time is dependant on the impedance of S_{Gn} or S_{Pn} node. The second switch status command will provide accurate switch status information. It is recommended that software wait 10 to 20 ms between the two switch status commands, allowing time for switch input voltages to stabilize. With all switch states acknowledged by the MCU, the sleep sequence may be initiated. All parameters for Sleep mode should be updated prior to sending the sleep command.

The 33972 IC has an internal 5.0 V supply from the VPWR pin. A POR circuit monitors the internal 5.0 V supply. In the

event of transients on the VPWR pin, an internal reset may occur. Upon reset the 33972 will enter Normal mode with the internal registers as defined in [Table 15](#), page 18. Therefore it is recommended that the MCU periodically update all registers internal to the IC.

USING THE $\overline{\text{WAKE}}$ FEATURE

The 33972 provides a $\overline{\text{WAKE}}$ output and wake-up input designed to control an enable pin on system power supply. While in the Normal mode, the $\overline{\text{WAKE}}$ output is LOW, enabling the power supply. In the Sleep mode, the $\overline{\text{WAKE}}$ pin is high, disabling the power supply. The $\overline{\text{WAKE}}$ pin has a passive pull-up to the internal 5.0 V supply but may be pulled up through a resistor to the V_{PWR} supply (see [Figure 17](#), page 25).

When the $\overline{\text{WAKE}}$ output is not used, the pin should be pulled up to the V_{DD} supply through a resistor as shown in [Figure 16](#), page 25.

During the Sleep mode, a switch closure will set the $\overline{\text{WAKE}}$ pin LOW, causing the 33972 to enter the Normal mode. The power supply will then be activated, supplying power to the VDD pin and the microprocessor and the 33972. The microprocessor can determine the source of the wake-up by reading the interrupt flag.

COST AND FLEXIBILITY

Systems requiring a significant number of switch interfaces have many discrete components. Discrete components on standard PWB consume board space and must be checked for solder joint integrity. An integrated approach reduces solder joints, consumes less board space, and offers wider operating voltage, analog interface capability, and greater interfacing flexibility.

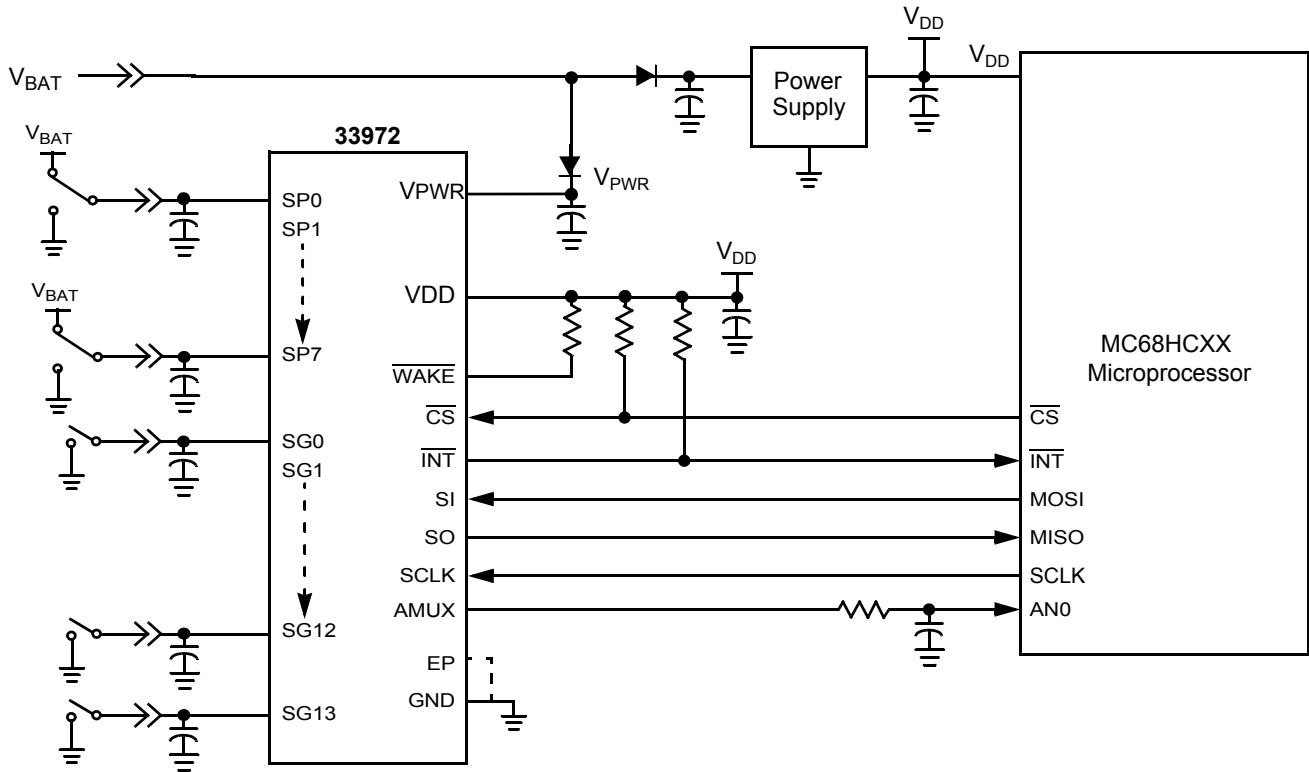

Figure 16. Power Supply Active in Sleep Mode

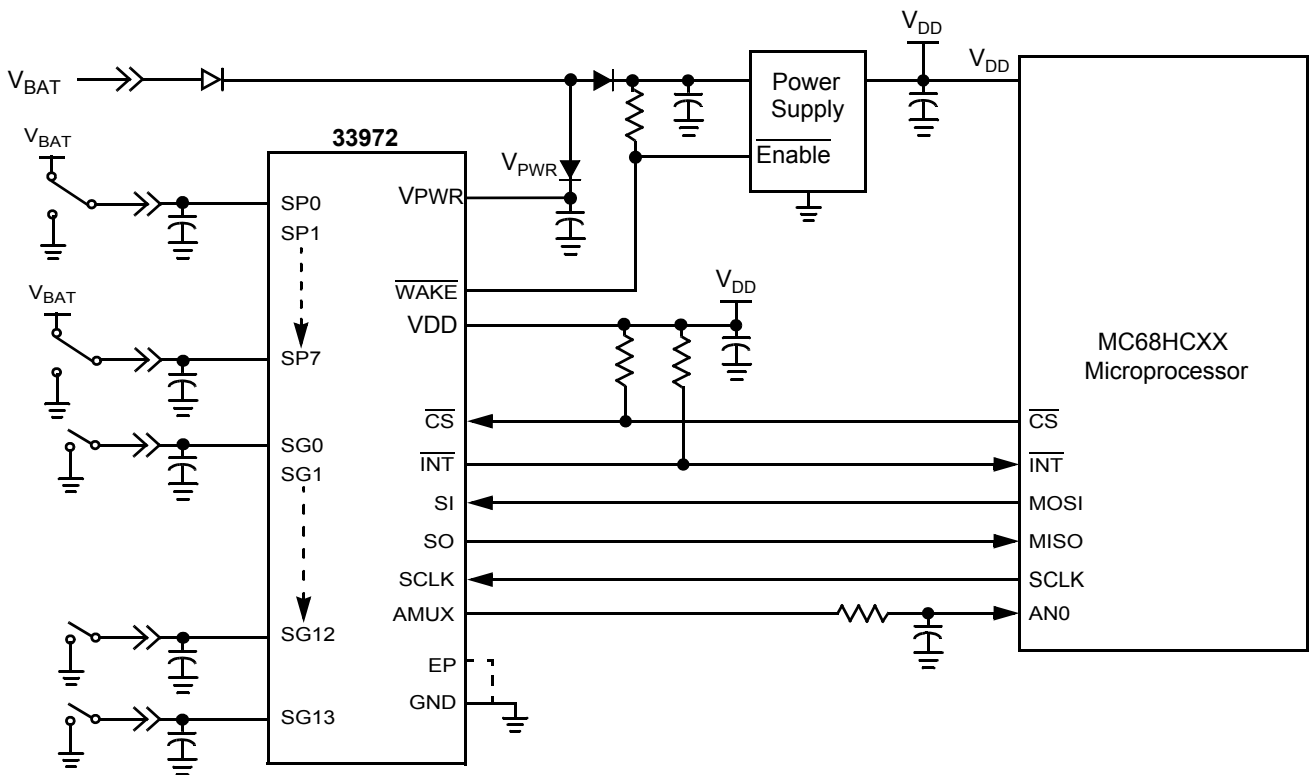
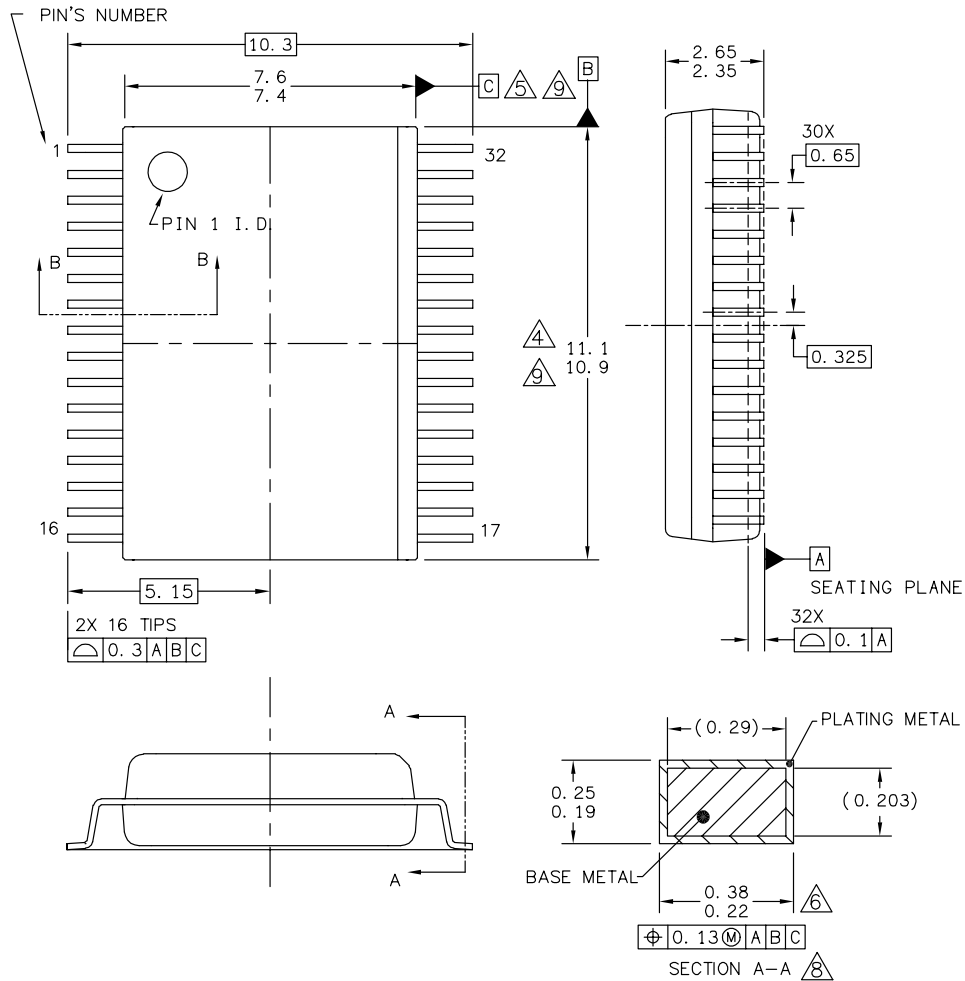

Figure 17. Power Supply Shutdown in Sleep Mode

PACKAGING

PACKAGE DIMENSIONS

For the most current package revision, visit www.freescale.com and perform a keyword search using the 98A listed below.



| | | | |
|---|---------------------------|----------------------------|--|
| © FREESCALE SEMICONDUCTOR, INC. ALL RIGHTS RESERVED. | MECHANICAL OUTLINE | PRINT VERSION NOT TO SCALE | |
| TITLE: 32LD SOIC W/B, 0.65 PITCH CASE OUTLINE | DOCUMENT NO: 98ARH99137A | REV: B | |
| | CASE NUMBER: 1324-03 | 07 APR 2005 | |
| | STANDARD: FREESCALE | | |

DWB SUFFIX
EW SUFFIX (Pb-FREE)
32-LEAD SOIC WIDE BODY
98ARH99137A
ISSUE B

PACKAGE DIMENSIONS (CONTINUED)

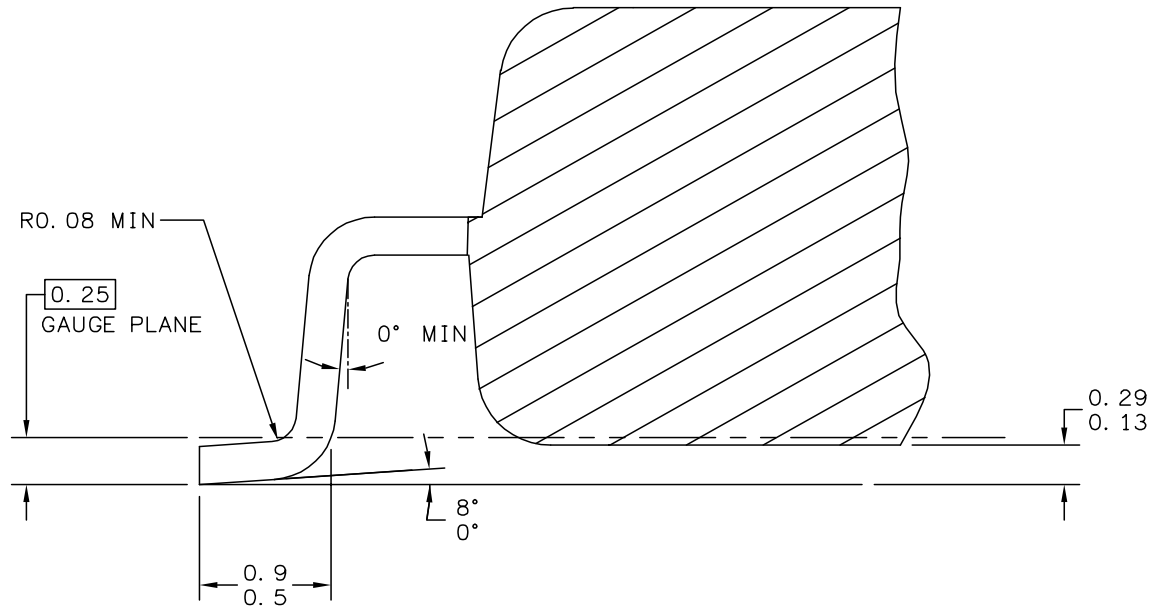

SECTION B-B

| | | | |
|---|---------------------------|----------------------------|--|
| © FREESCALE SEMICONDUCTOR, INC. ALL RIGHTS RESERVED. | MECHANICAL OUTLINE | PRINT VERSION NOT TO SCALE | |
| TITLE: 32LD SOIC W/B, 0.65 PITCH CASE OUTLINE | DOCUMENT NO: 98ARH99137A | REV: B | |
| | CASE NUMBER: 1324-03 | 07 APR 2005 | |
| | STANDARD: FREESCALE | | |

DWB SUFFIX
EW SUFFIX (Pb-FREE)
32-LEAD SOIC WIDE BODY
98ARH99137A
ISSUE B

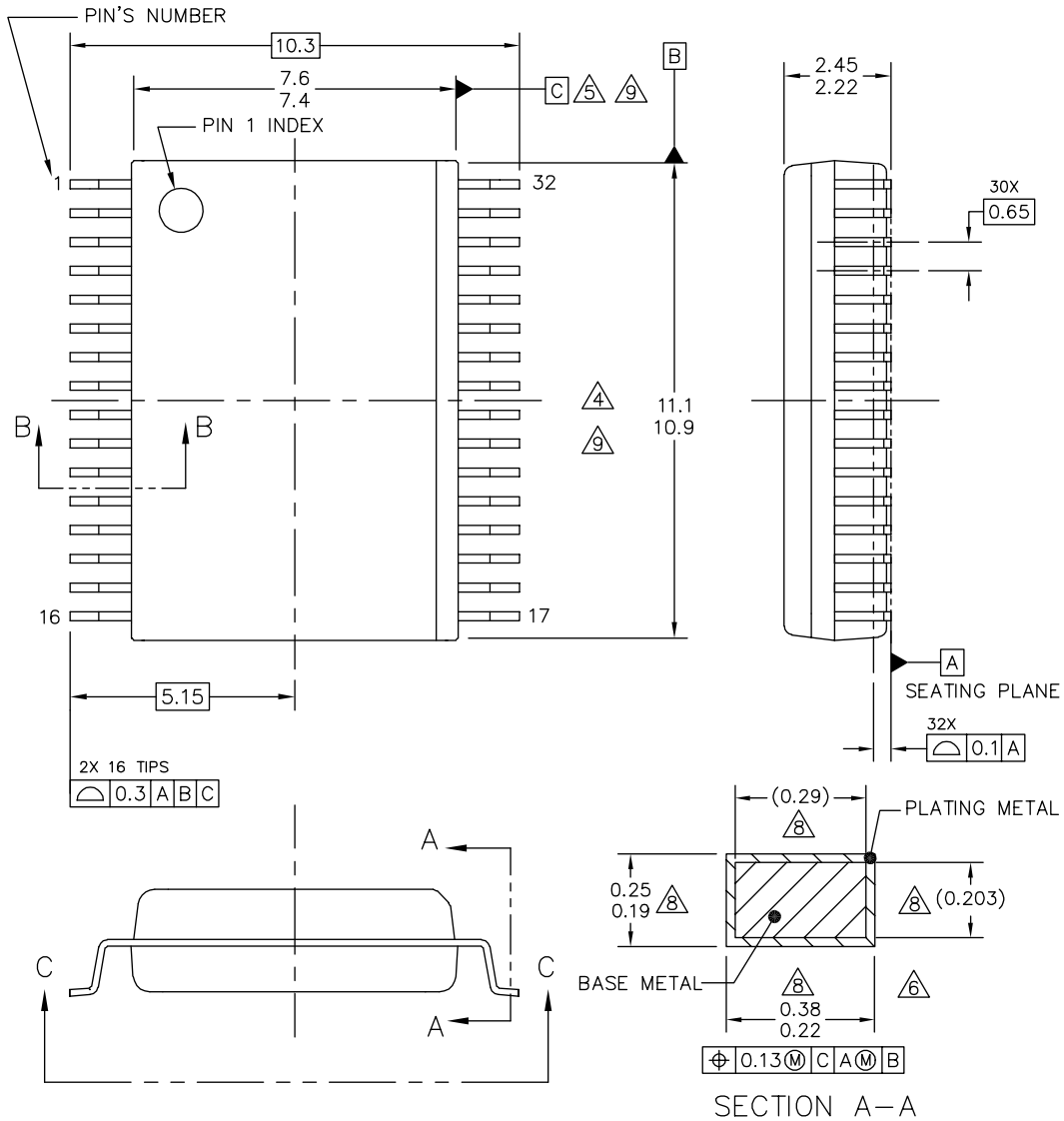

| | | | | |
|---|--|----------------------|----------------------------|--------|
| © FREESCALE SEMICONDUCTOR, INC. ALL RIGHTS RESERVED. | MECHANICAL OUTLINE | | PRINT VERSION NOT TO SCALE | |
| | TITLE: 32LD SOIC W/B, 0.65 PITCH 4.7 X 4.7 EXPOSED PAD, CASE-OUTLINE | | DOCUMENT NO: 98ASA10556D | REV: D |
| | | CASE NUMBER: 1454-04 | 20 JUN 2008 | |
| | | STANDARD: NON-JEDEC | | |

EK SUFFIX (Pb-FREE)
32-LEAD SOIC WIDE BODY
EXPOSED PAD
98ASA10556D
ISSUE D

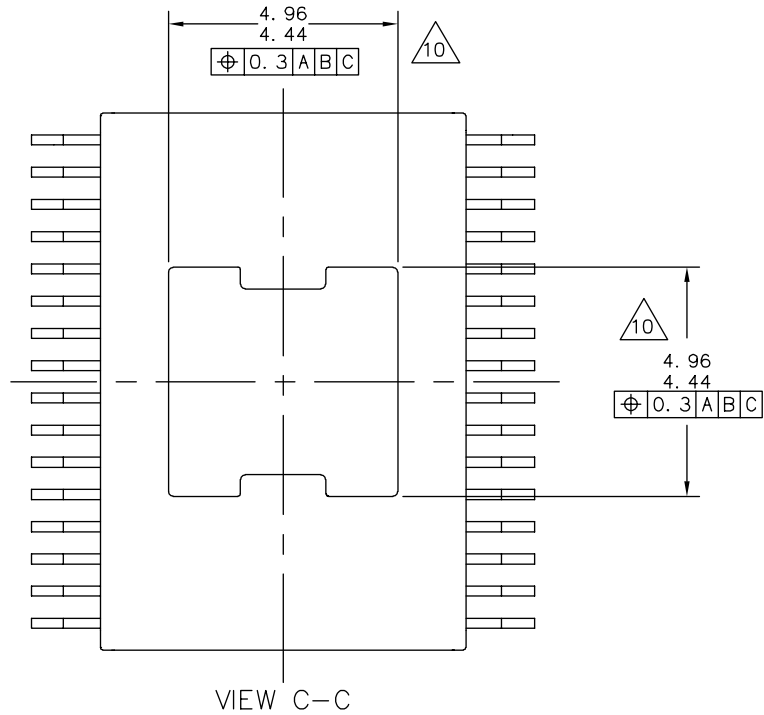
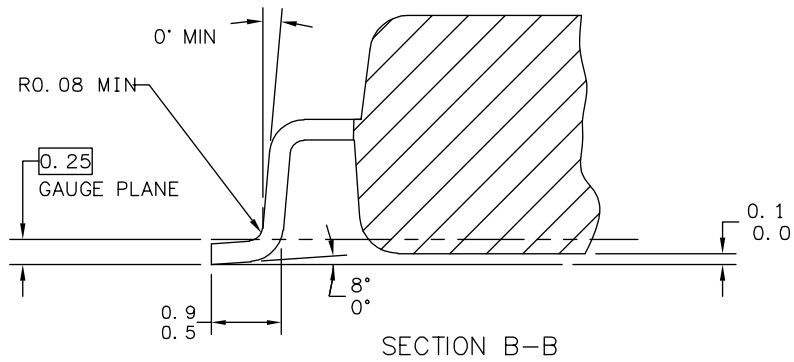

| | | | |
|--|---------------------------|----------------------------|--|
| © FREESCALE SEMICONDUCTOR, INC. ALL RIGHTS RESERVED. | MECHANICAL OUTLINE | PRINT VERSION NOT TO SCALE | |
| TITLE: 32LD SOIC W/B, 0.65 PITCH 4.7 X 4.7 EXPOSED PAD, CASE-OUTLINE | DOCUMENT NO: 98ASA10556D | REV: D | |
| | CASE NUMBER: 1454-04 | 20 JUN 2008 | |
| | STANDARD: NON-JEDEC | | |

EK SUFFIX (Pb-FREE)
32-LEAD SOIC WIDE BODY
EXPOSED PAD
98ASA10556D
ISSUE D

NOTES:

1. DIMENSIONS ARE IN MILLIMETERS.
2. DIMENSIONING AND TOLERANCING PER ASME Y14.5M-1994.
3. DATUMS B AND C TO BE DETERMINED AT THE PLANE WHERE THE BOTTOM OF THE LEADS EXIT THE PLASTIC BODY.
4. THIS DIMENSION DOES NOT INCLUDE MOLD FLASH, PROTRUSION OR GATE BURRS. MOLD FLASH, PROTRUSION OR GATE BURRS SHALL NOT EXCEED 0.15 MM PER SIDE. THIS DIMENSION IS DETERMINED AT THE PLANE WHERE THE BOTTOM OF THE LEADS EXIT THE PLASTIC BODY.
5. THIS DIMENSION DOES NOT INCLUDE INTER-LEAD FLASH OR PROTRUSIONS. INTER-LEAD FLASH AND PROTRUSIONS SHALL NOT EXCEED 0.25 MM PER SIDE. THIS DIMENSION IS DETERMINED AT THE PLANE WHERE THE BOTTOM OF THE LEADS EXIT THE PLASTIC BODY.
6. THIS DIMENSION DOES NOT INCLUDE DAMBAR PROTRUSION. ALLOWABLE DAMBAR PROTRUSION SHALL NOT CAUSE THE LEAD WIDTH TO EXCEED 0.4 mm. DAMBAR CANNOT BE LOCATED ON THE LOWER RADIUS OR THE FOOT. MINIMUM SPACE BETWEEN PROTRUSION AND ADJACENT LEAD SHALL NOT LESS THAN 0.07 mm.
7. EXACT SHAPE OF EACH CORNER IS OPTIONAL.
8. THESE DIMENSIONS APPLY TO THE FLAT SECTION OF THE LEAD BETWEEN 0.10 mm AND 0.3 mm FROM THE LEAD TIP.
9. THE PACKAGE TOP MAY BE SMALLER THAN THE PACKAGE BOTTOM. THIS DIMENSION IS DETERMINED AT THE OUTERMOST EXTREMES OF THE PLASTIC BODY EXCLUSIVE OF MOLD FLASH, TIE BAR BURRS, GATE BURRS AND INTER-LEAD FLASH, BUT INCLUDING ANY MISMATCH BETWEEN THE TOP AND BOTTOM OF THE PLASTIC BODY.
10. THESE DIMENSION RANGES DEFINE THE PRIMARY KEEP-OUT AREA. MOLD LOCKING AND RESIN BLEED CONTROL FEATURES MAY BE VISIBLE AND THEY MAY EXTEND TO 0.34mm FROM MAXIMUM EXPOSED PAD SIZE

| | | | |
|--|---------------------------|----------------------------|--|
| © FREESCALE SEMICONDUCTOR, INC. ALL RIGHTS RESERVED. | MECHANICAL OUTLINE | PRINT VERSION NOT TO SCALE | |
| TITLE: 32LD SOIC W/B, 0.65 PITCH 4.7 X 4.7 EXPOSED PAD, CASE-OUTLINE | DOCUMENT NO: 98ASA10556D | REV: D | |
| | CASE NUMBER: 1454-04 | 20 JUN 2008 | |
| | STANDARD: NON-JEDEC | | |

EK SUFFIX (Pb-FREE)
 32-LEAD SOIC WIDE BODY
 EXPOSED PAD
 98ASA10556D
 ISSUE D

REVISION HISTORY

| REVISION | DATE | DESCRIPTION OF CHANGES |
|----------|---------|--|
| 4.0 | 2/2006 | <ul style="list-style-type: none"> Converted to Freescale format Added PC33972A version Changed Figure 15, Power Supply Active in Sleep Mode Changed Figure 16, Power Supply Shutdown in Sleep Mode Updated Outline Drawing for package |
| 5.0 | 6/2006 | <ul style="list-style-type: none"> Update to the prevailing Freescale form and style. |
| 6.0 | 7/2006 | <ul style="list-style-type: none"> Added MC33972T devices. Updated Static Electrical Characteristics on page 6 with 33972T parameters. |
| 7.0 | 11/2006 | <ul style="list-style-type: none"> Changed Human Body Model parameters in Maximum Ratings table. Replaced Part Number MC33972TEW/R2 with MCZ33972TEW/R2 Removed Peak Package Reflow Temperature During Reflow (solder reflow) parameter from Maximum Ratings on page 5. Added note with instructions to obtain this information from www.freescale.com. |
| 8.0 | 12/2006 | <ul style="list-style-type: none"> Restated note ⁽⁶⁾ Changed Part Number MCZ33972TEW/R2 with MC33972TEW/R2 |
| 9.0 | 4/2007 | <ul style="list-style-type: none"> Removed all references to the 33972T device. Removed the MC33972TDWB/R2, MC33972TEW/R2, and PC33972AEW/R2 from the ordering information. Added MCZ33972AEW/R2 to the ordering information. |
| 10.0 | 6/2007 | <ul style="list-style-type: none"> Added MC33972EW/R2, MC33972TDWB/R2, MC33972TEW/R2, and MCZ33972TEW/R2 to the ordering information. |
| 11.0 | 11/2007 | <ul style="list-style-type: none"> Updated to the current Freescale form and style Added MC33972AEK/R2 to the ordering information. Included device specific information relevant to the EK suffix on pages 1, 2, 4, 5, 6, 27, and 28. Added sentence to CHIP SELECT (CS) on page 10 Made calculation corrections to Analog Sensor Inputs (Ratiometric) |
| 12.0 | 12/2007 | <ul style="list-style-type: none"> Corrected Device Variation Table on page 2. |
| 13.0 | 12/2007 | <ul style="list-style-type: none"> Replaced Outline Drawing 98ARL10543D with 98ASA10556D. |
| 14 | 6/2008 | <ul style="list-style-type: none"> Added Note 7, "T_C is the T_{CASE} of the package" to Electrical Characteristics Table. |
| 15 | 8/2008 | <ul style="list-style-type: none"> Updated package drawing 98ASA10556D |
| 16 | 10/2009 | <ul style="list-style-type: none"> Updated data sheet status from Advance Information to Technical Data Updated to the current Freescale form and style |

How to Reach Us:

Home Page:

www.freescale.com

Web Support:

<http://www.freescale.com/support>

USA/Europe or Locations Not Listed:

Freescale Semiconductor, Inc.
Technical Information Center, EL516
2100 East Elliot Road
Tempe, Arizona 85284
1-800-521-6274 or +1-480-768-2130
www.freescale.com/support

Europe, Middle East, and Africa:

Freescale Halbleiter Deutschland GmbH
Technical Information Center
Schatzbogen 7
81829 Muenchen, Germany
+44 1296 380 456 (English)
+46 8 52200080 (English)
+49 89 92103 559 (German)
+33 1 69 35 48 48 (French)
www.freescale.com/support

Japan:

Freescale Semiconductor Japan Ltd.
Headquarters
ARCO Tower 15F
1-8-1, Shimo-Meguro, Meguro-ku,
Tokyo 153-0064
Japan
0120 191014 or +81 3 5437 9125
support.japan@freescale.com

Asia/Pacific:

Freescale Semiconductor China Ltd.
Exchange Building 23F
No. 118 Jianguo Road
Chaoyang District
Beijing 100022
China
+86 10 5879 8000
support.asia@freescale.com

For Literature Requests Only:

Freescale Semiconductor Literature Distribution Center
P.O. Box 5405
Denver, Colorado 80217
1-800-441-2447 or +1-303-675-2140
Fax: +1-303-675-2150
LDCForFreescaleSemiconductor@hibbertgroup.com

Information in this document is provided solely to enable system and software implementers to use Freescale Semiconductor products. There are no express or implied copyright licenses granted hereunder to design or fabricate any integrated circuits or integrated circuits based on the information in this document.

Freescale Semiconductor reserves the right to make changes without further notice to any products herein. Freescale Semiconductor makes no warranty, representation or guarantee regarding the suitability of its products for any particular purpose, nor does Freescale Semiconductor assume any liability arising out of the application or use of any product or circuit, and specifically disclaims any and all liability, including without limitation consequential or incidental damages. "Typical" parameters that may be provided in Freescale Semiconductor data sheets and/or specifications can and do vary in different applications and actual performance may vary over time. All operating parameters, including "Typicals", must be validated for each customer application by customer's technical experts. Freescale Semiconductor does not convey any license under its patent rights nor the rights of others. Freescale Semiconductor products are not designed, intended, or authorized for use as components in systems intended for surgical implant into the body, or other applications intended to support or sustain life, or for any other application in which the failure of the Freescale Semiconductor product could create a situation where personal injury or death may occur. Should Buyer purchase or use Freescale Semiconductor products for any such unintended or unauthorized application, Buyer shall indemnify and hold Freescale Semiconductor and its officers, employees, subsidiaries, affiliates, and distributors harmless against all claims, costs, damages, and expenses, and reasonable attorney fees arising out of, directly or indirectly, any claim of personal injury or death associated with such unintended or unauthorized use, even if such claim alleges that Freescale Semiconductor was negligent regarding the design or manufacture of the part.



Freescale™ and the Freescale logo are trademarks of Freescale Semiconductor, Inc. All other product or service names are the property of their respective owners.

© Freescale Semiconductor, Inc. 2009. All rights reserved.

MC33972
Rev. 16.0
10/2009