

Tous droits strictement reserves. Reproduction ou communication a des tiers interdite sous quelque forme que ce soit sans autorisation ecrite du proprietaire. Propriete de c FCI. Droits de reproduction FCI.

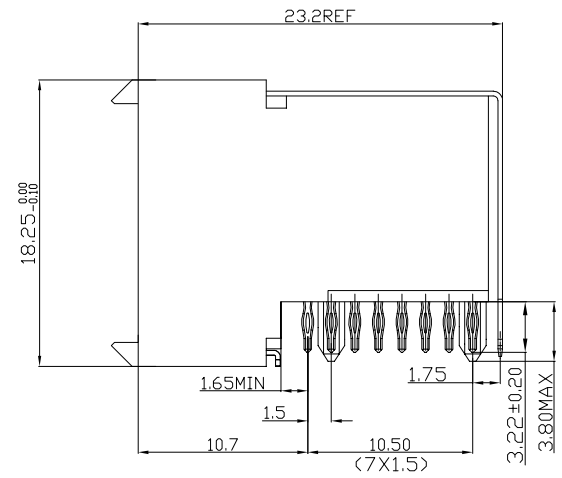

All rights strictly reserved. Reproduction or issue to third parties in any form whatever is not permitted without written authority from the proprietor. Property of FCI. Copyright FCI.

1 2 3 4

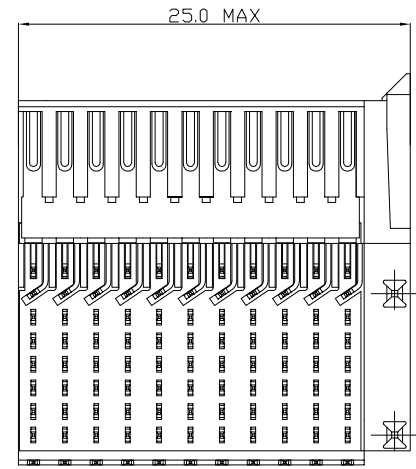
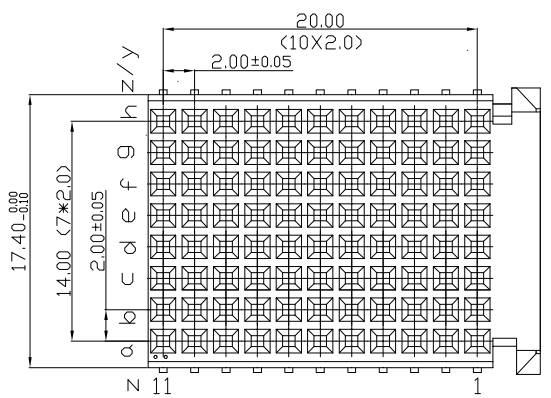

**PERFORMANCE CHARACTERISTICS**  
 CURRENT RATING 1.5A AT 20°C (FULLY LOADED)  
 1 A AT 70°C (FULLY LOADED)  
 RATED VOLTAGE : 500 V AC (CONT /CONT)  
 OPERATING TEMPERATURE : -55°C TO 125°C  
 CONTACT RESISTANCE 20 MΩ MAX  
 INSERTION FORCE : 0.75N MAX/CONT  
 EXTRACTION FORCE : 0.15N MIN/CONT  
 INSULATION RESISTANCE : 10<sup>4</sup> MΩ MIN

- NOTES**
- LEAD FREE INDICATOR 4LF=LEAD FREE  
 PERFORMANCE LEVEL INDICATOR (REF DWG NO:BS.C.201844.003)
  - THIS PRODUCT IS CSA APPROVED. THIS PRODUCT IS UL RECOGNIZED.
  - FOR RECOMMENDED PTH DIMENSIONS REFER DRAWING : BS.A.201572.001
  - THIS PRODUCT (4LF) MEETS EUROPEAN UNION DIRECTIVES AND OTHER COUNTRY REGULATIONS AS DESCRIBED IN GS-22-008

LAY-OUT P.C.B. 1 HOLE

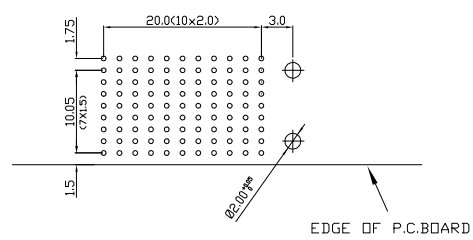

www.fciconnect.com		tolerance 1DEC ±0.2 1DEC 2DEC ±0.1 2DEC ANGLES ±1° HOEKEN	projection 	MM 
Dr	M.Fret	08-04-99	Product family	MILLIPICS
Eng			Spec ref	
Chr			Material	
Appr			size	A4
			ECN	Scale 3/1
title	MPACS 8+2R RA RCP CONN TYPE FR/WITH SHIELDED			Rev. D
catalog no	HM2R82PA8104----			sheet 1 of 1
dwg no	BS,C ,202260,013			CUSTOMER

rev	ecn no	dr	date
A	CONVERSION REVISION 01	KN	14-09-01
B	DG05-0381	Kasor	10-10-05
C	DG07-0362	Kasor	05-09-07
D	DG10-0110	NZ	05-30-10