

CIRCUIT BOARD HOLE LOCATIONS
AND KEEP CLEAR AREAS FOR
ATM13-12Px-12Px-BM01
ATM13-12Px-12Px-BM03
ALL DIMENSIONS REFERENCE
TOP VIEW

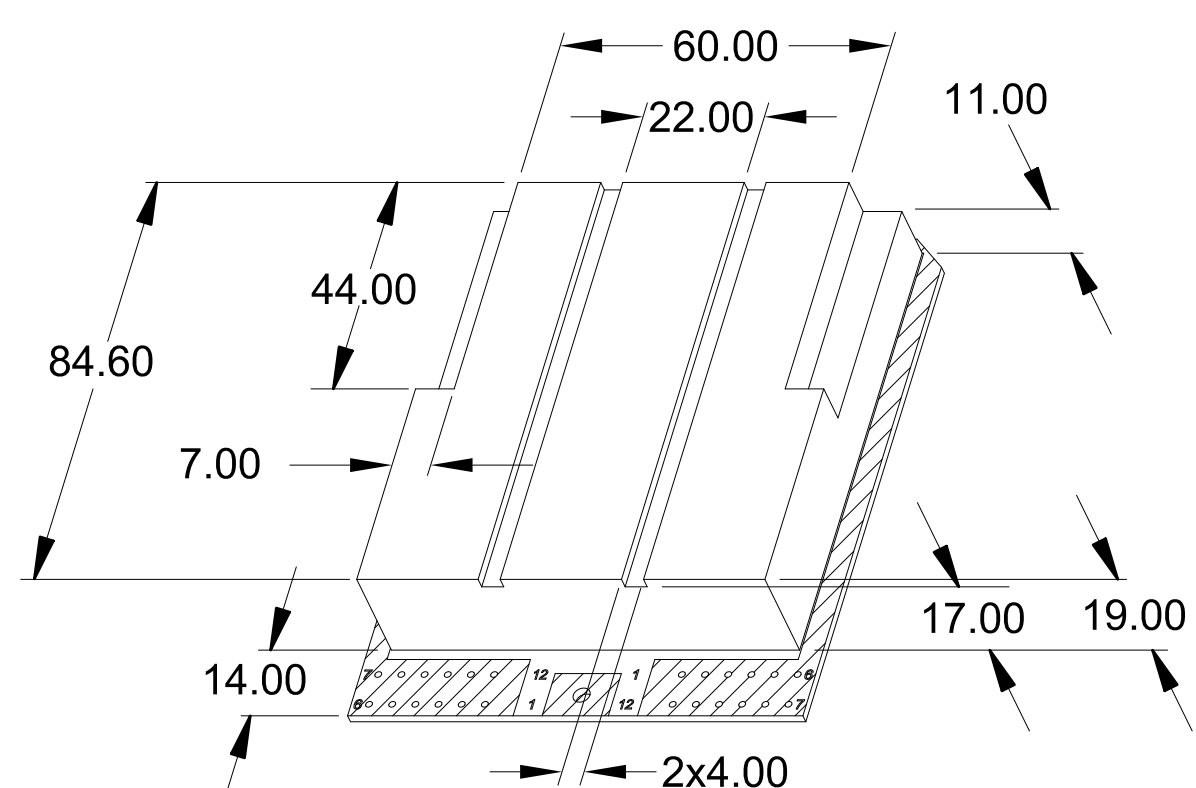

THREE DIMENSIONAL SPACE LIMIT
APPROXIMATE INTERNAL SPACE
FOR COMPONENT SPACE LAYOUT
MAX. COMPONENT HEIGHT UNDER BOARD 2.00 mm.

ASSEMBLED HEADER SHOWN FOR REFERENCE

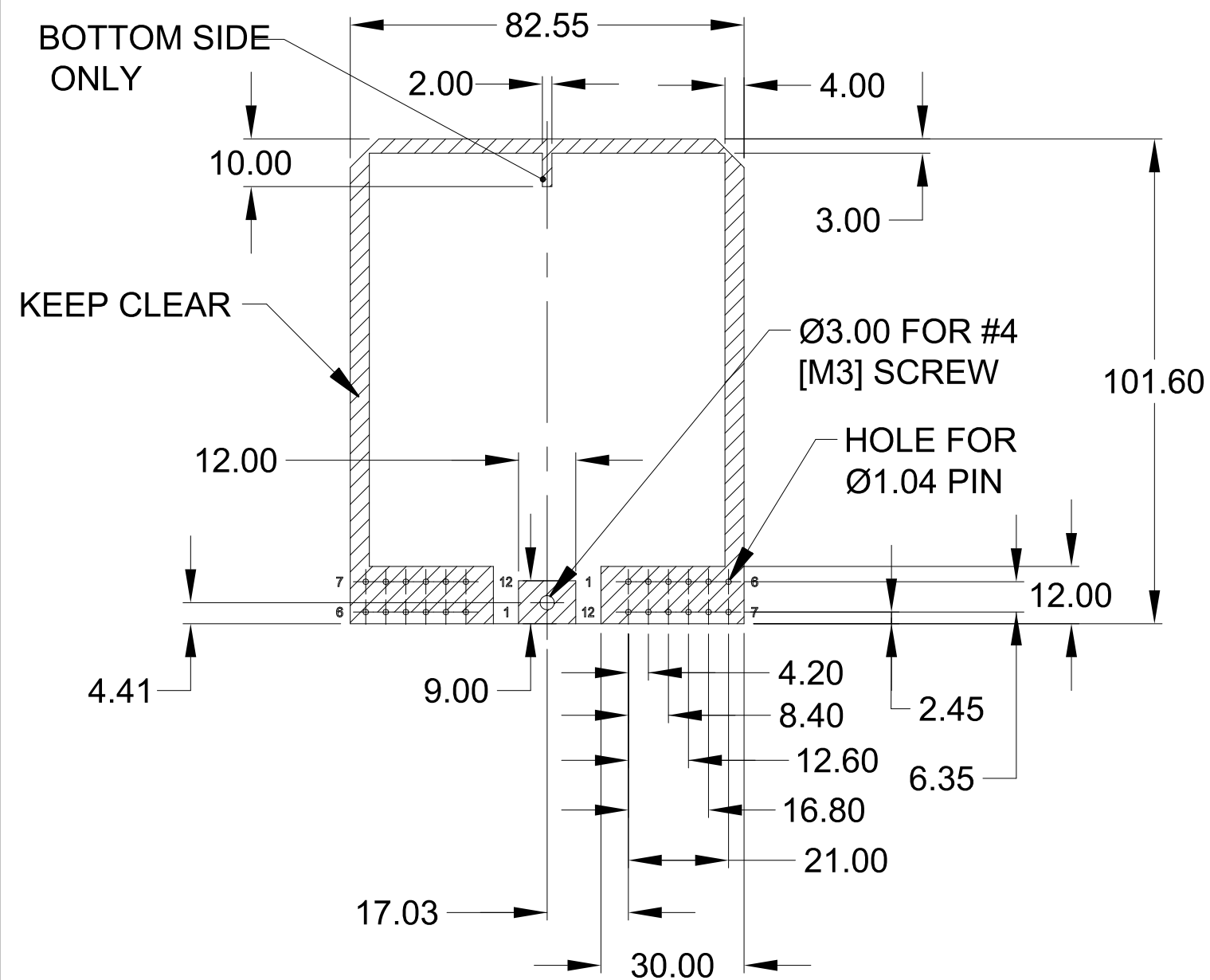
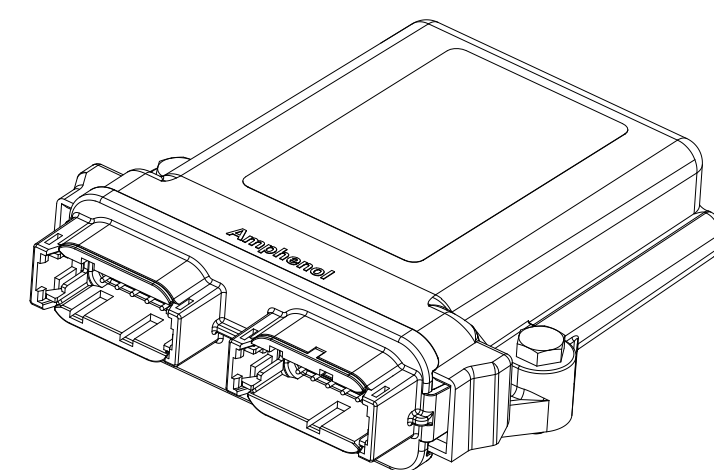
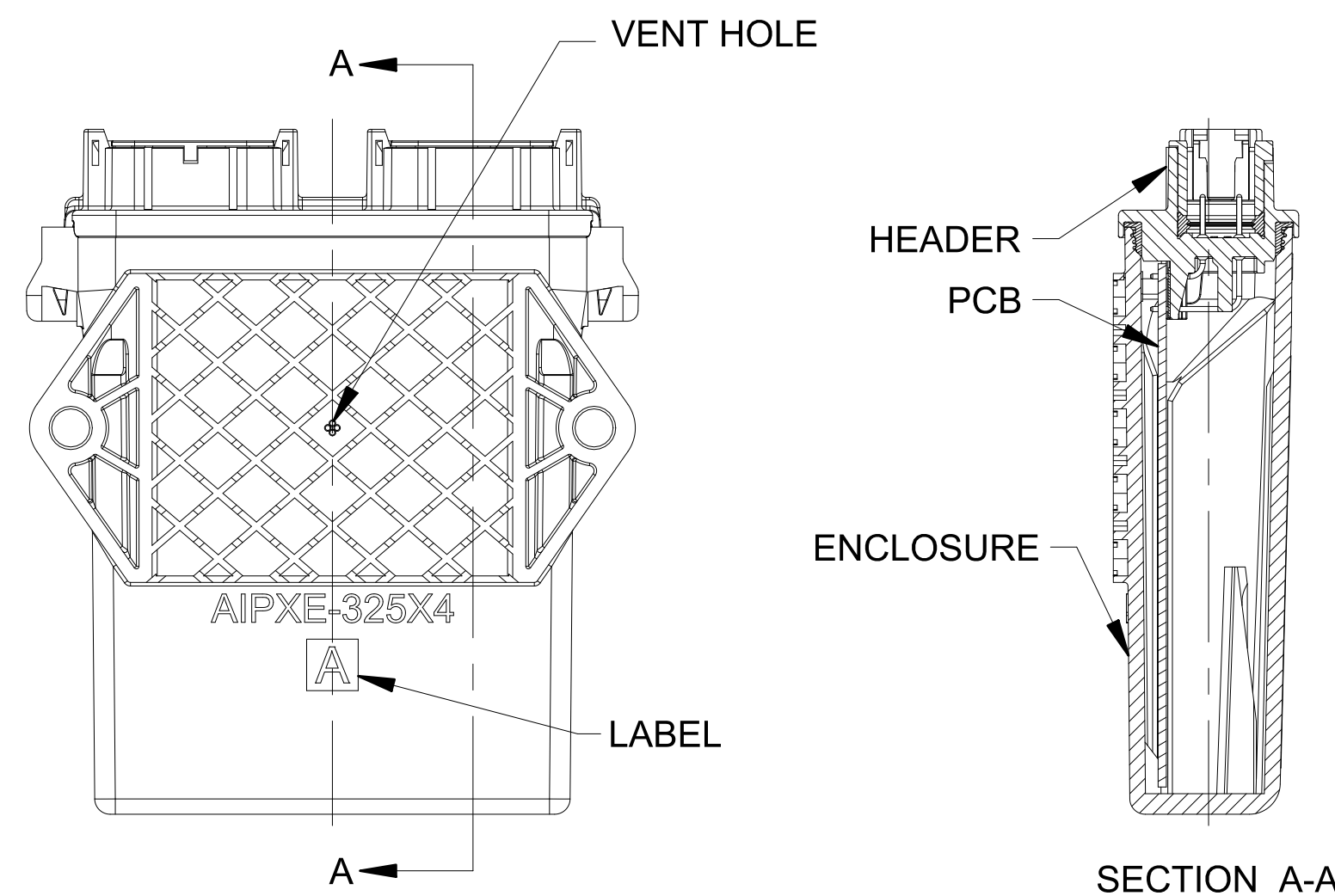
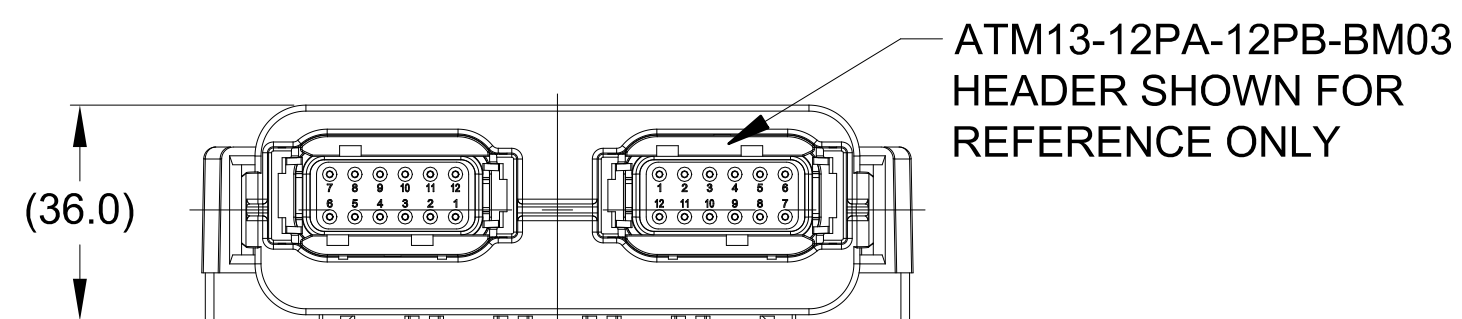
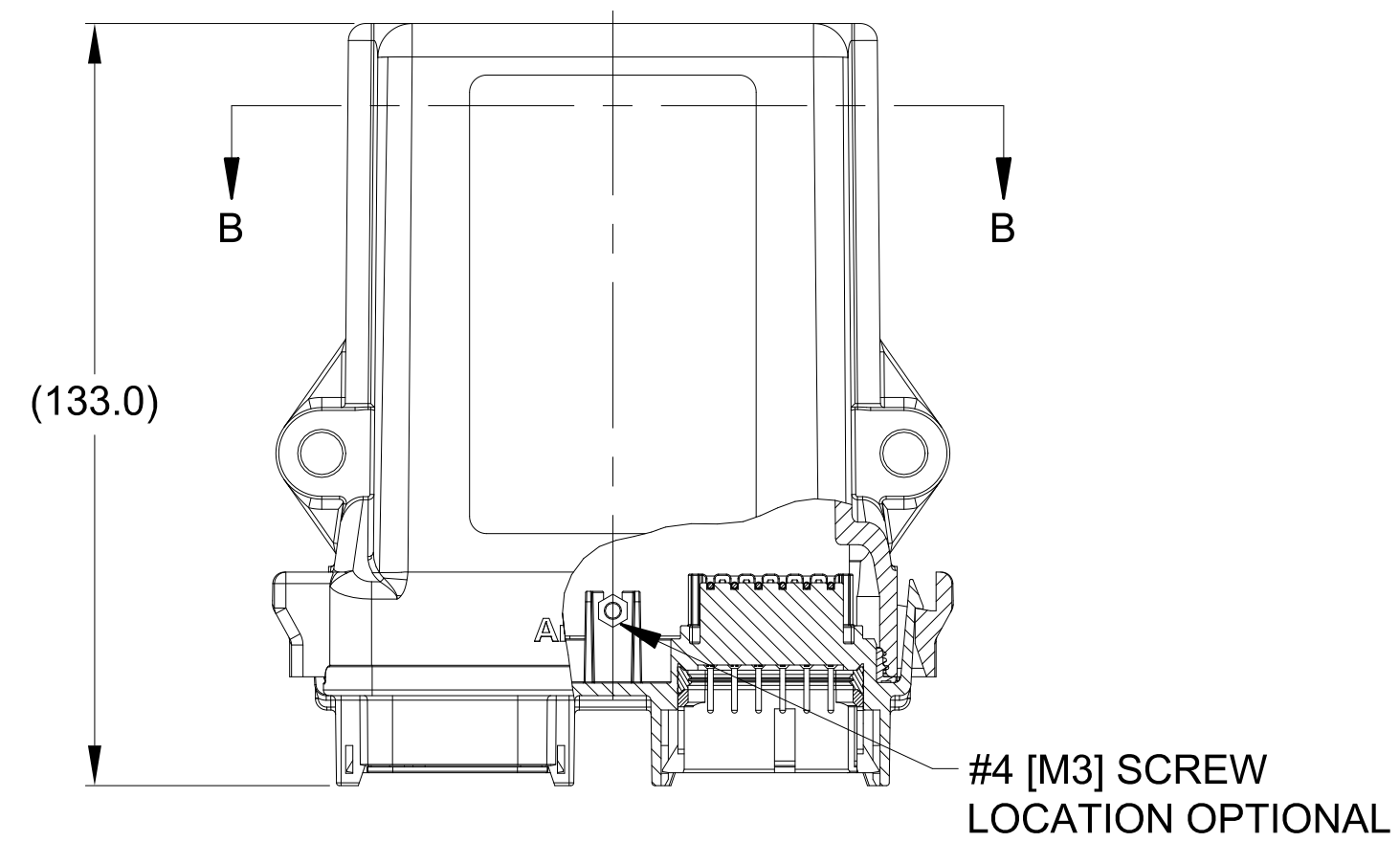
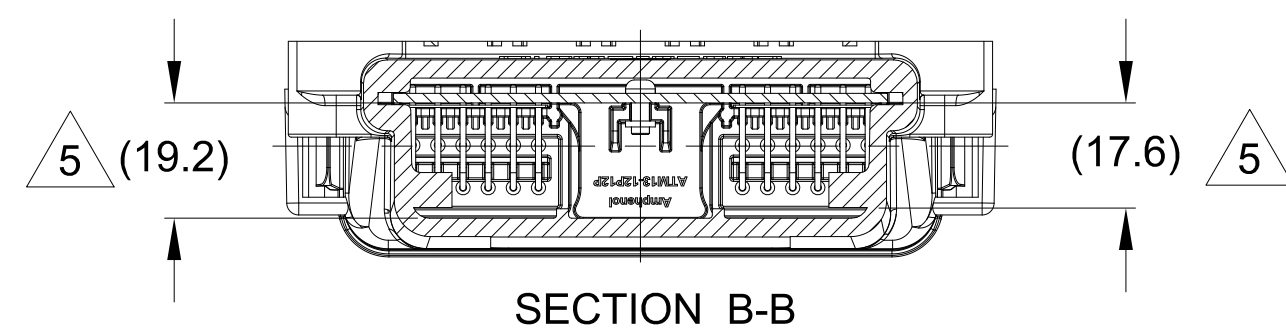

3D VIEW
ATM13-12Px-12Px-BM01 AND
ATM13-12Px-12Px-BM03 HEADER AND MOUNTING
HARDWARE SHOWN FOR REFERENCE

NOTES: UNLESS OTHERWISE SPECIFIED

- MATERIAL:NATURAL ULTEM
- THIS ENCLOSURE MATES WITH ATM13-12Px-12Px-BM0* & ATM13-12Px-GR01 / R008 HEADER AND AIPXE-325XBP-01. (x= A,B,C,D KEYS, *=ALL MODIFICATIONS)
- RoHS COMPLIANT
- ALL DIMENSIONS ARE FOR REFERENCE USE ONLY.
- MAXIMUM COMPONENT HEIGHT DEPENDS ON LOCATION DUE TO PART DRAFT AND RIBS.

REVISIONS

REV	ECO	DESCRIPTION	DATE	BY	APPR
A1	-	RELEASE NEW DRAWING	06NOV18	SULLEN	TOMMY
A2	-	UPDATED DRAWING	18FEB19	SULLEN	TOMMY
A3	-	ADD AMPHENOL LOGO	08APR19	SULLEN	TOMMY
A4	-	UPDATED DRAWING	10DEC19	SULLEN	TOMMY
A5	-	UPDATED SPACE LIMIT DIMENSION	15JAN20	SULLEN	TOMMY
A6	-	UPDATED DIMENSIONS	15NOV21	MILO	TOMMY

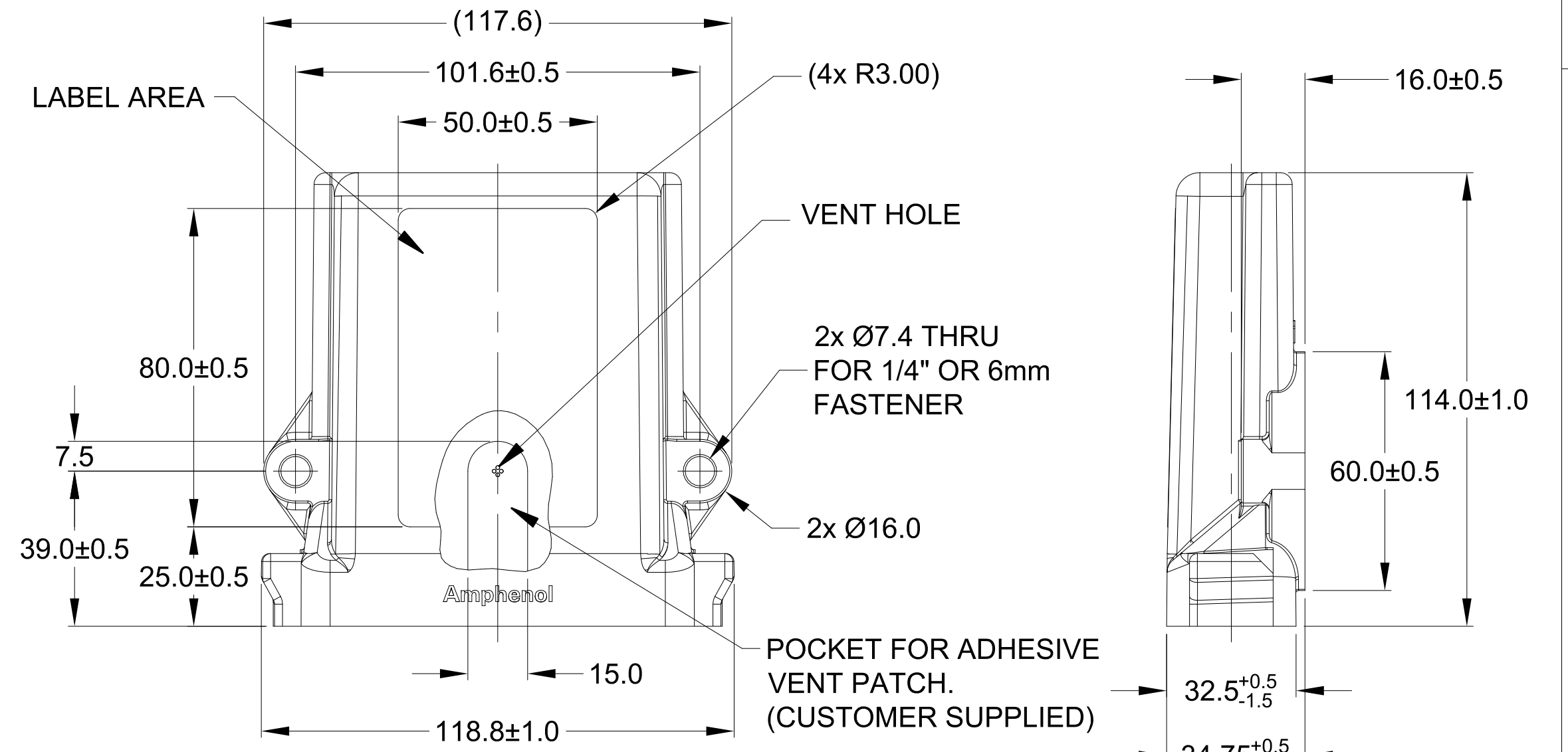

PART NUMBER CHART			
LABEL	VENT HOLE	PART NUMBER	
A	WITH VENT HOLES	AIPXE-325X4A-E016	EEC-325X4A-E016
B	WITHOUT VENT HOLES	AIPXE-325X4B-E016	EEC-325X4B-E016

QUANTITY	PART NUMBER	DESCRIPTION	ITEM
MATERIALS LIST			

UNLESS OTHERWISE SPECIFIED
1) All dimensions are in metric (mm).
2) Tolerances are as follows:
1 PL DEC ±0.30
2 PL DEC ±0.15
3 PL DEC ±0.08
Fractions ±1/64
Angles ±1°
3) Note reference = X

SIGNATURES DATE
DRAWN: MILO.DONG 15NOV21
CHECKED: SULLEN.ZHANG 16NOV21
ENGINEER: VITO.LI 17NOV21
APPROVAL: TOMMY.XIE 18NOV21

MATERIAL SPECIFICATIONS:
PROCESS SPECIFICATIONS:
NEXT ASSY:

Amphenol
Sine Systems - www.amphenol-sine.com
44724 Morley Drive
Clinton Township, MI 48036

ARMOR IPX PCB ENCLOSURE, AMBER,
SHOWN WITH 24 PIN HEADER
SIZE TYPE DWG NO: REVISION
B C- AIPXE-325X4x-E016 A6
SCALE: NONE SHEET 1 OF 1

TITLE: ARMOR IPX PCB ENCLOSURE, AMBER SHOWN WITH 24 PIN HEADER

DWG NO: AIPXE-325X4x-E016

REV: A6

SH: 1

OF: 1