

LOC	DIST	P	F	ZONE	LTR	DESCRIPTION	DATE	APPD
AR	39				J	REV&REDRAWN ECN 2275	-	-
					K	REACTIVATE 3-1 PER ECN BD3808	4-3-90	GDM
					L	REV PER ECN BD4149	8-15-90	-
					M	REV PER EC BD6679	03/04/93	GDM
					N	OBsolete -38 PER EC 0020-0943-93	11/18/93	DK
					P	SUPSD -4,-6,-8,-16,-18,-24, -26,-28,-30,-32,-34,-36 PER EC 0020-0700-94	04/24/95	DK
					R	OBS -2,-10,-14 PER EC 0020-0680-94	04/24/95	DK
					RI	REVISED PER ECO-09-020774	21AUG09	AEG

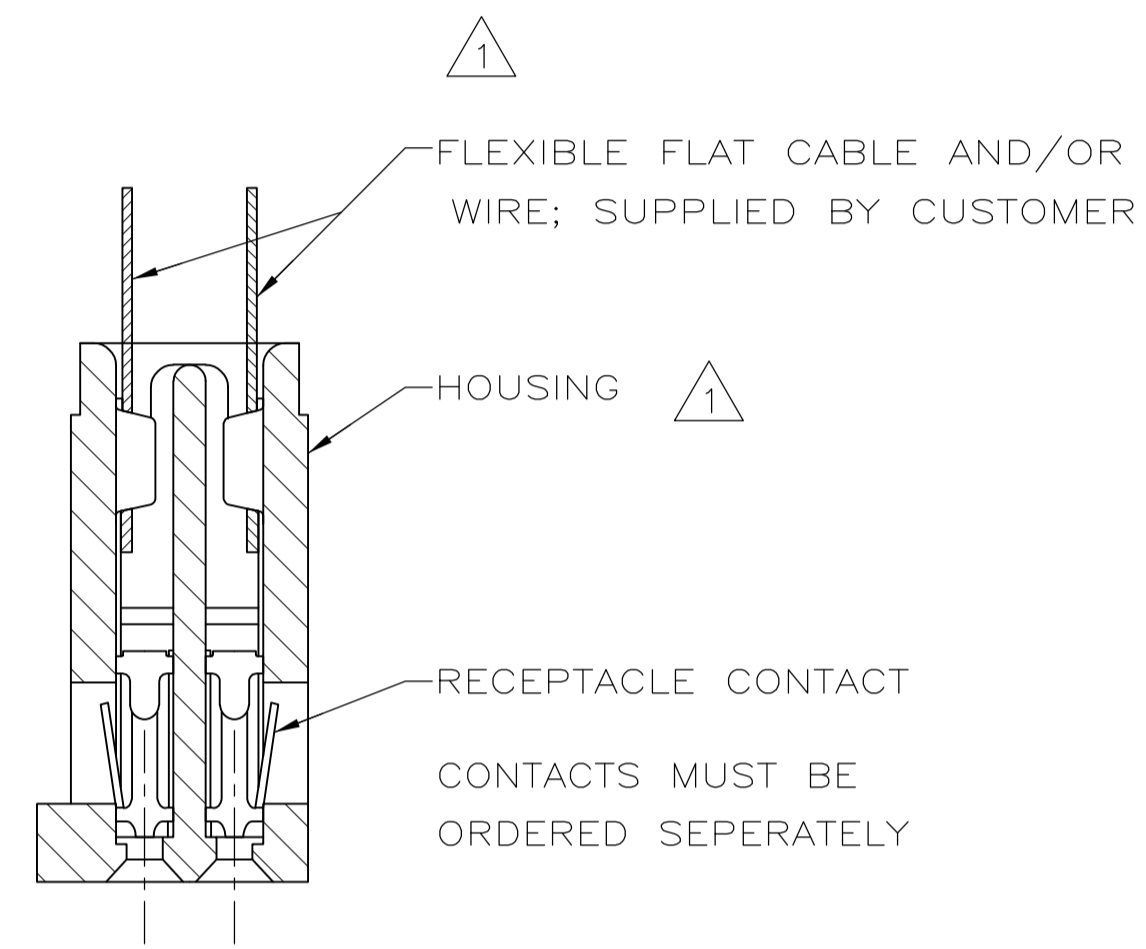
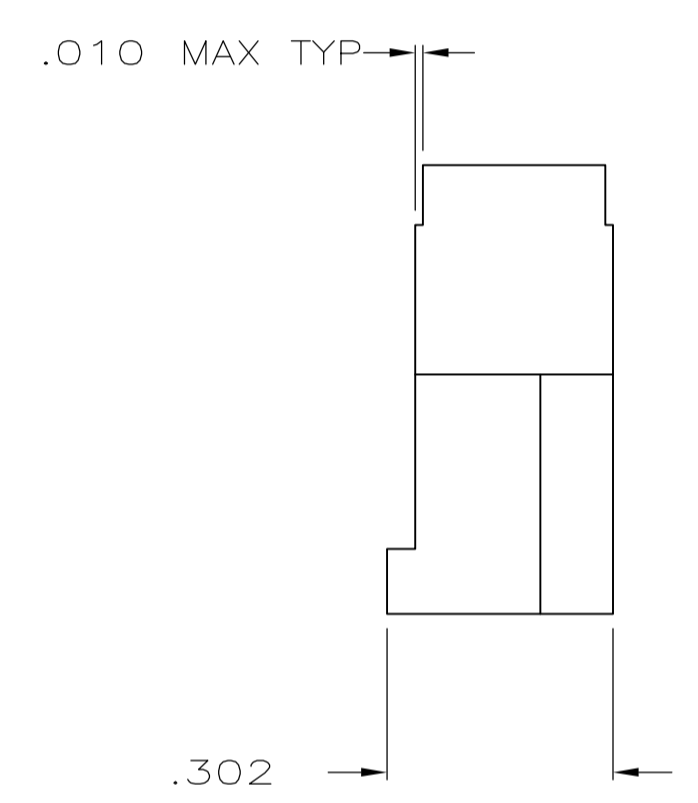
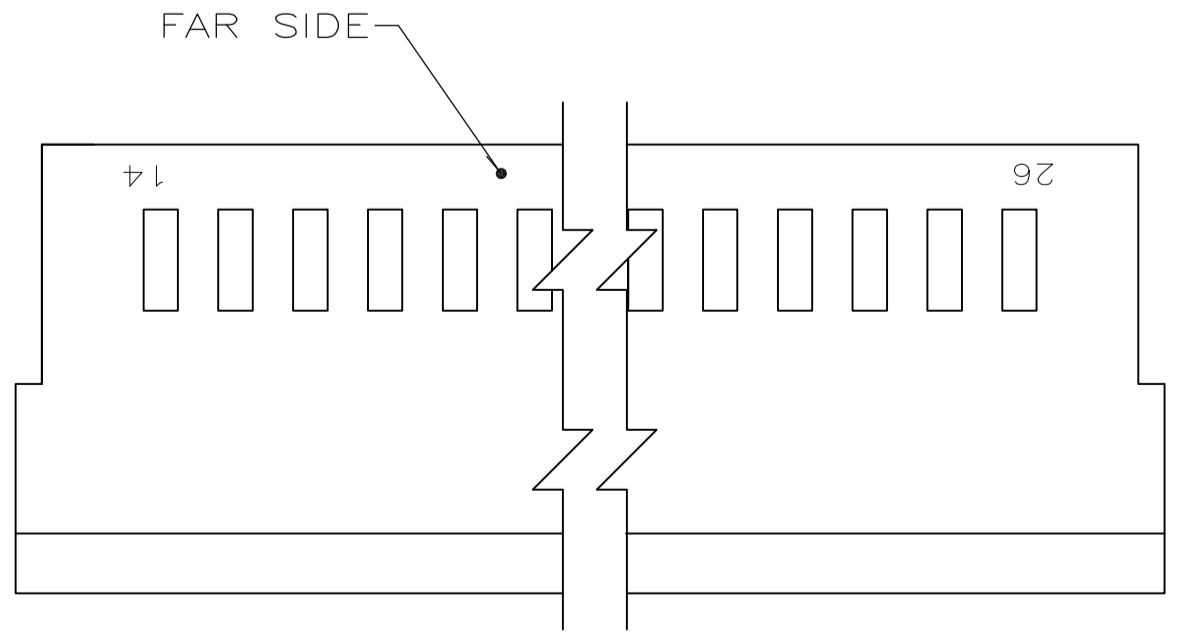
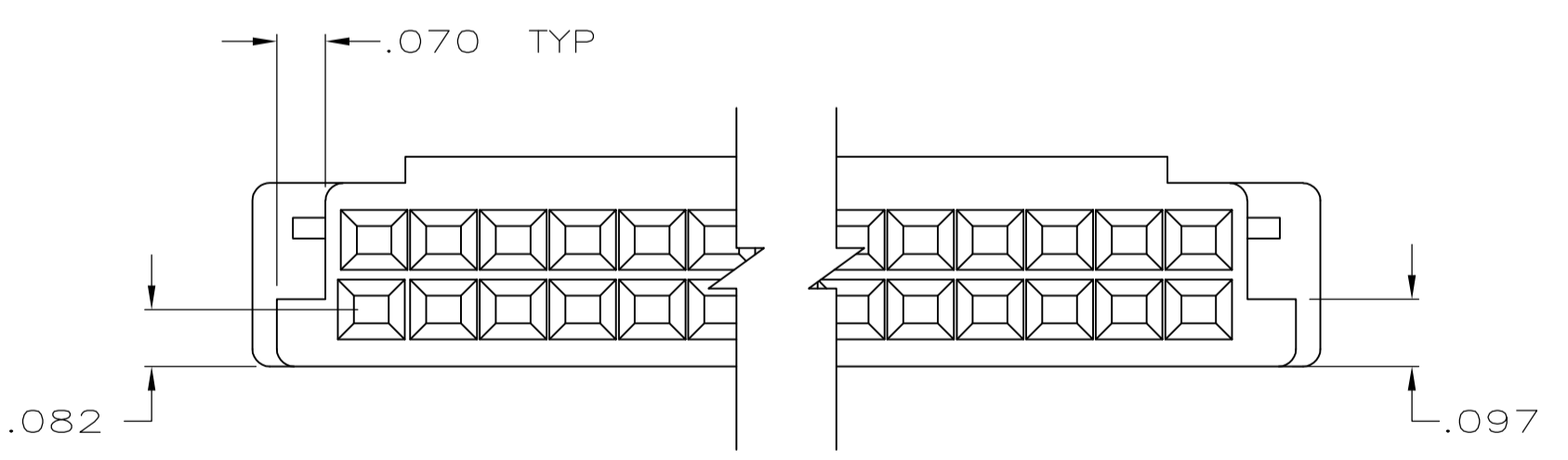
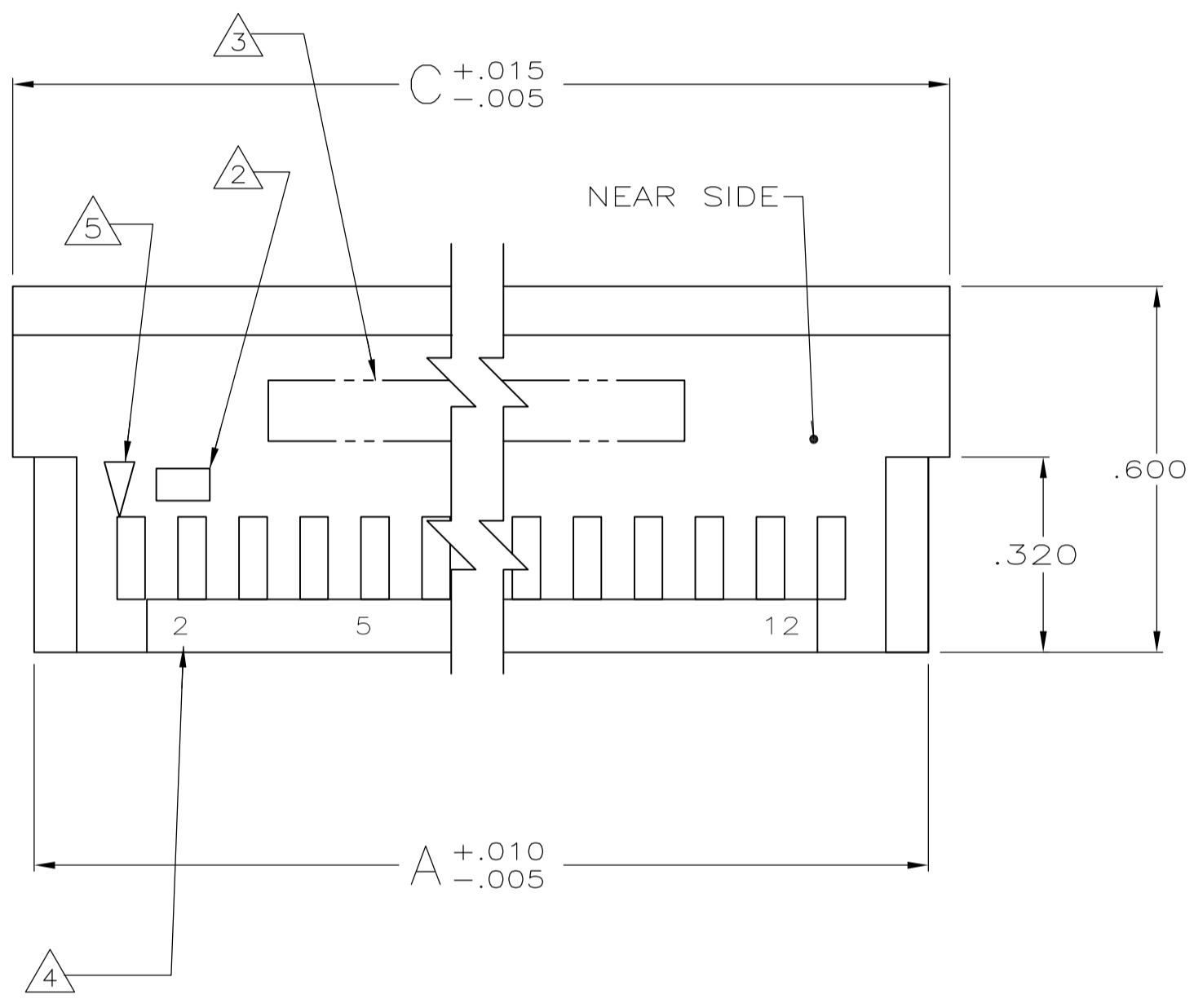
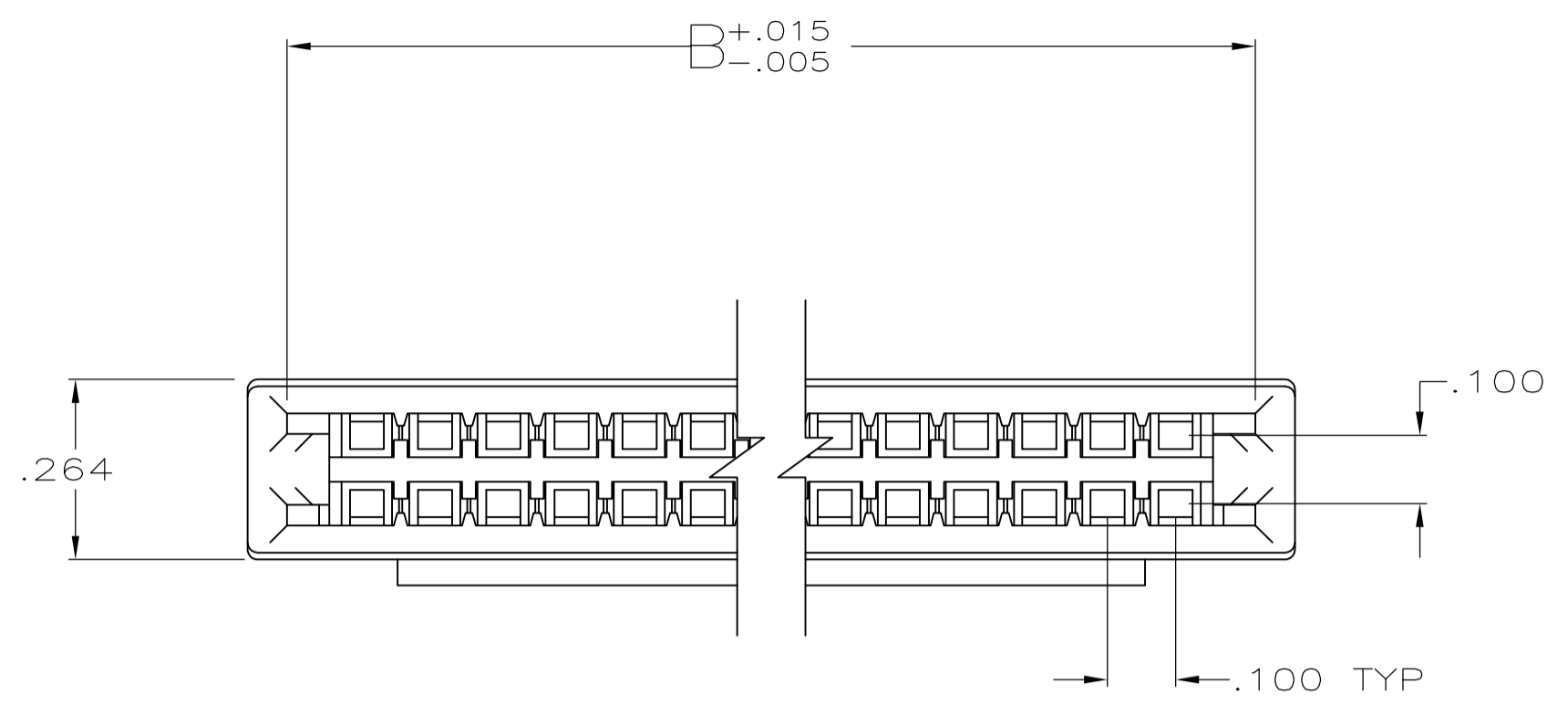

CRIMPED CONTACTS INSERTED FOR REFERENCE ONLY

- ① HOUSING WILL ACCOMMODATE FLEXIBLE FLAT CABLE .050 OR .062 WIDE CONDUCTORS ON .100 CENTERS AND/OR #22-32 AWG WIRE WITH INSULATION RANGE OF .025 TO .056
- ② AMP TRADEMARK MOLDED IN THIS AREA
- ③ PART NO. AND DATE CODE INK STAMPED, WHITE.
- ④ CONTACT POSITION NOS. INK STAMPED, WHITE, BOTH SIDES (SEE TABLE)
- ⑤ INDICATES POSITION 1
- ⑥ PART NO. SUPERSEDED BY AS MOLDED PART NO.
- ⑦ OBSOLETE PART NO.

⑧ PART NUMBER	SUPERSEDED BY
86673-4	88179-6
86673-6	88179-5
86673-8	2-88179-2
1-86673-6	2-88179-4
1-86673-8	1-88179-4
2-86673-4	3-88179-0
2-86673-6	2-88179-0
2-86673-8	1-88179-2
3-86673-0	3-88179-2
3-86673-2	88179-4
3-86673-4	3-88179-4
3-86673-6	3-88179-6

⑨ OBSOLETE PARTS: OBSOLETE CIS STREAMLINING PER D.RENAUD/D.SINISI

⑩ 3-86673-7	2,5,10	12,15,22	1.350	1.234	1.280	22	⑩ 3-86673-8
⑩ 3-86673-5	2,5,10,16	18,25,30,34	1.950	1.834	1.880	34	⑩ 3-86673-6
⑩ 3-86673-3	2,5	7,12	.850	.734	.780	12	⑩ 3-86673-4
⑩ 3-86673-1	2,5,10,15,20,25,29	31,35,40,45,50,55,60	3.250	3.134	3.180	60	⑩ 3-86673-2
⑩ 2-86673-9	2		.550	.434	.480	6	⑩ 3-86673-0
⑩ 2-86673-7	2,5,10,15,20,24	26,30,35,40,45,50	2.750	2.634	2.680	50	⑩ 2-86673-8
⑩ 2-86673-5	2,5,10,17	19,25,30,36	2.050	1.934	1.980	36	⑩ 2-86673-6
⑩ 2-86673-3	2,4	6,10	.750	.634	.680	10	⑩ 2-86673-4
⑩ 2-86673-1	2,5,10,13	15,20,25,28	1.650	1.534	1.580	28	⑩ 2-86673-2
⑩ 1-86673-9	2,5,12	14,20,26	1.550	1.434	1.480	26	⑩ 2-86673-0
⑩ 1-86673-7	2,5,11	13,20,24	1.450	1.334	1.380	24	⑩ 1-86673-8
⑩ 1-86673-5	2,5,10,15,21	23,30,35,40,44	2.450	2.334	2.380	44	⑩ 1-86673-6
⑩ 1-86673-3	2,5,10,15,20,25,28	30,35,40,45,50,55,58	3.150	3.034	3.080	58	⑩ 1-86673-4
⑩ 1-86673-1	2,5,8	10,15,18	1.150	1.034	1.080	18	⑩ 1-86673-2
⑩ 86673-9	2,5,10,15,20,25,32	34,40,45,50,55,60,66	3.550	3.434	3.480	66	⑩ 1-86673-0
⑩ 86673-7	2,5,10,15,19	21,25,30,35,40	2.250	2.134	2.180	40	⑩ 86673-8
⑩ 86673-5	2,5,9	11,15,20	1.250	1.134	1.180	20	⑩ 86673-6
⑩ 86673-3	2,5,10,15,18	20,25,30,35,38	2.150	2.034	2.080	38	⑩ 86673-4
⑩ 86673-1	2,5,10,15,20,25,30,34	36,40,45,50,55,60,65,70	3.750	3.634	3.680	70	⑩ 86673-2

INK STAMPED PART NO.	NEAR SIDE	FAR SIDE	C	B	A	NO OF POSN	AS MOLDED PART NO.
	CAVITY POSN NO. STAMPED						

DO NOT SCALE PRINT. UNLESS SPECIFIED DIMENSIONS IN INCHES TOLERANCES - ON : 2 PLC DEC ± .005 ANGLES ± -	DR 2/16/89 J. GALLUCCI CHK 3-3-89 D.ROCKER APPD 3-3-89 G.D.MILLER APPD 3-3-89 W.PARKER	AMP INCORPORATED Harrisburg, Pa. 17105
MATERIAL NYLON, GLASS FILLED COLOR: BLACK	PRODUCT SPEC -	NAME HOUSING, RCPT, DBL ROW, .100 , FFC
FINISH -	APPLICATION SPEC -	SIZE D 00779
WEIGHT -		DRAWING NO 86673
		SCALE 4:1
		SHEET 1 OF 1