

REVISIONS			
REV	DESCRIPTION, ECN, EAR NO.	DATE	APP'D
B	UPDATE SHIELD WITH NOTCH	APR12/17	L.CHAN
C	REVISE DRAWING	SEP26/21	L.CHAN

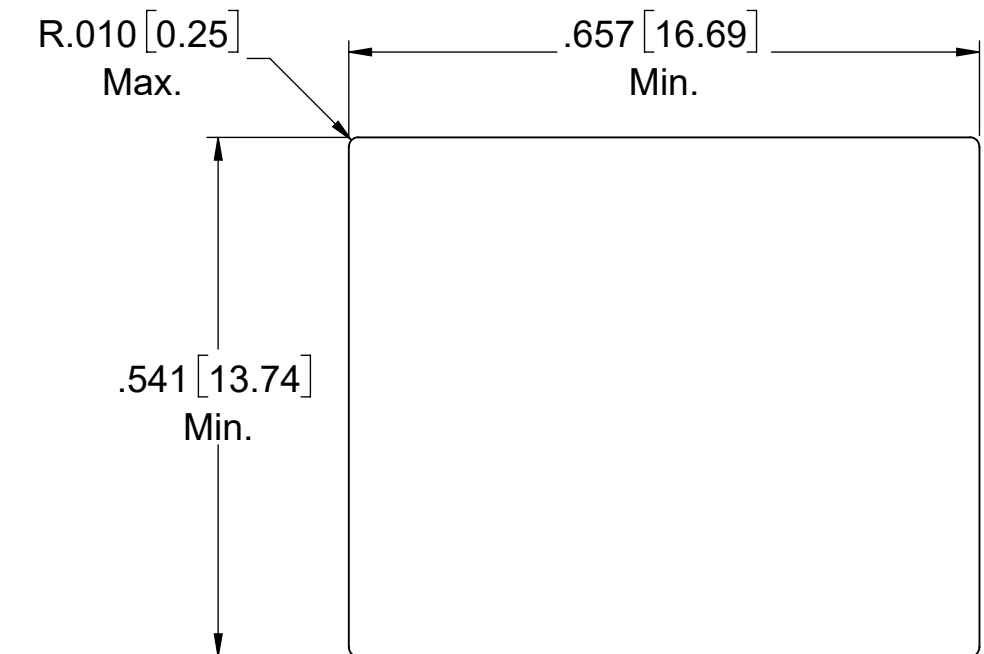

RECOMMEND PANEL CUTOUT

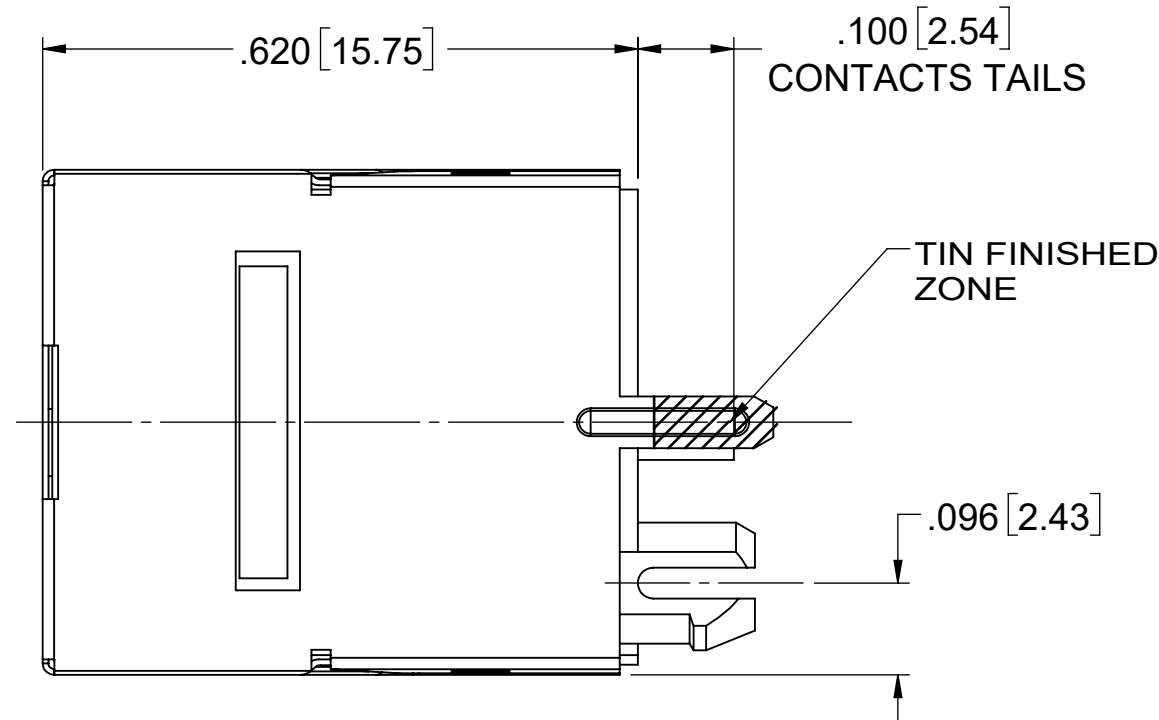
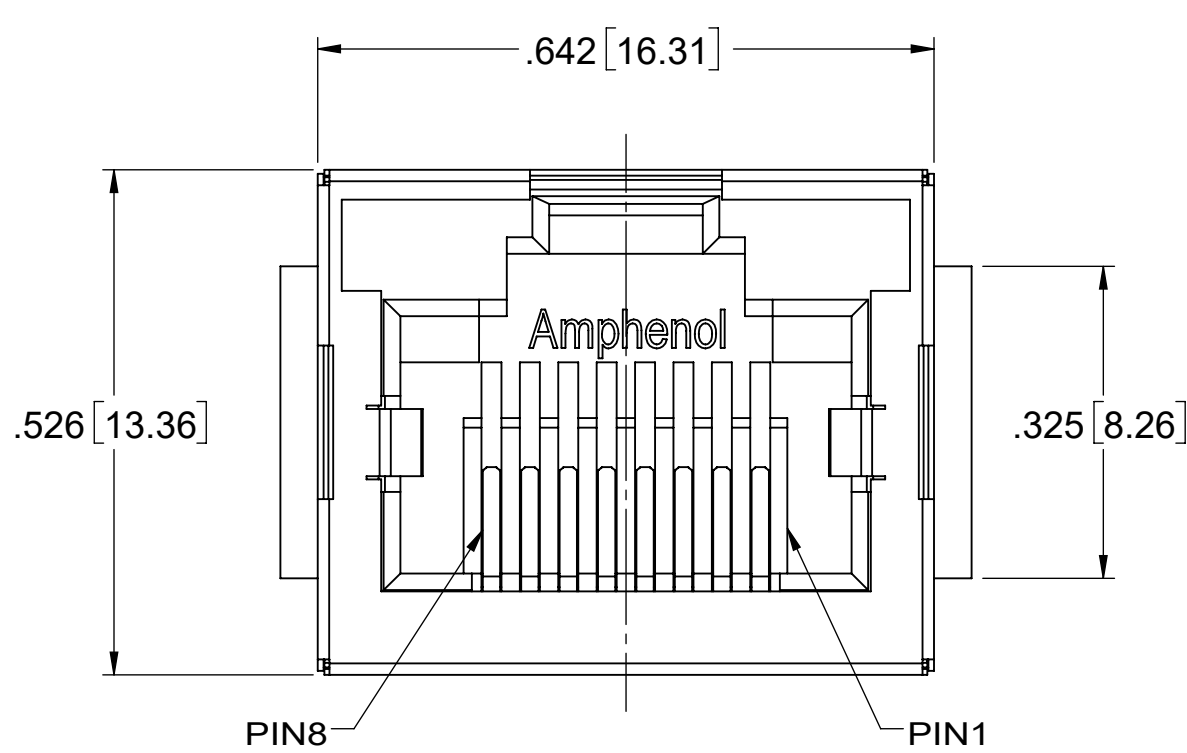
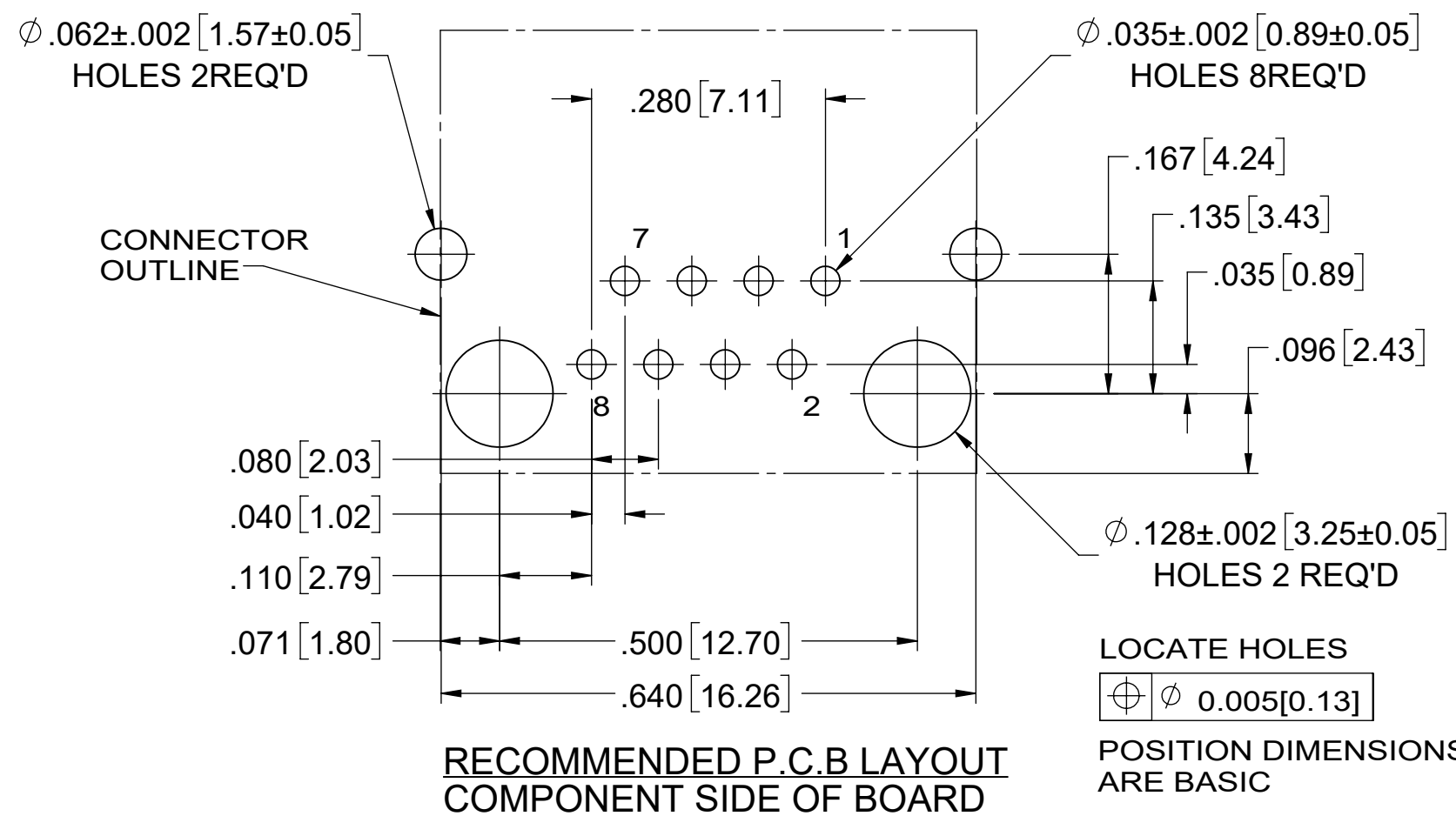
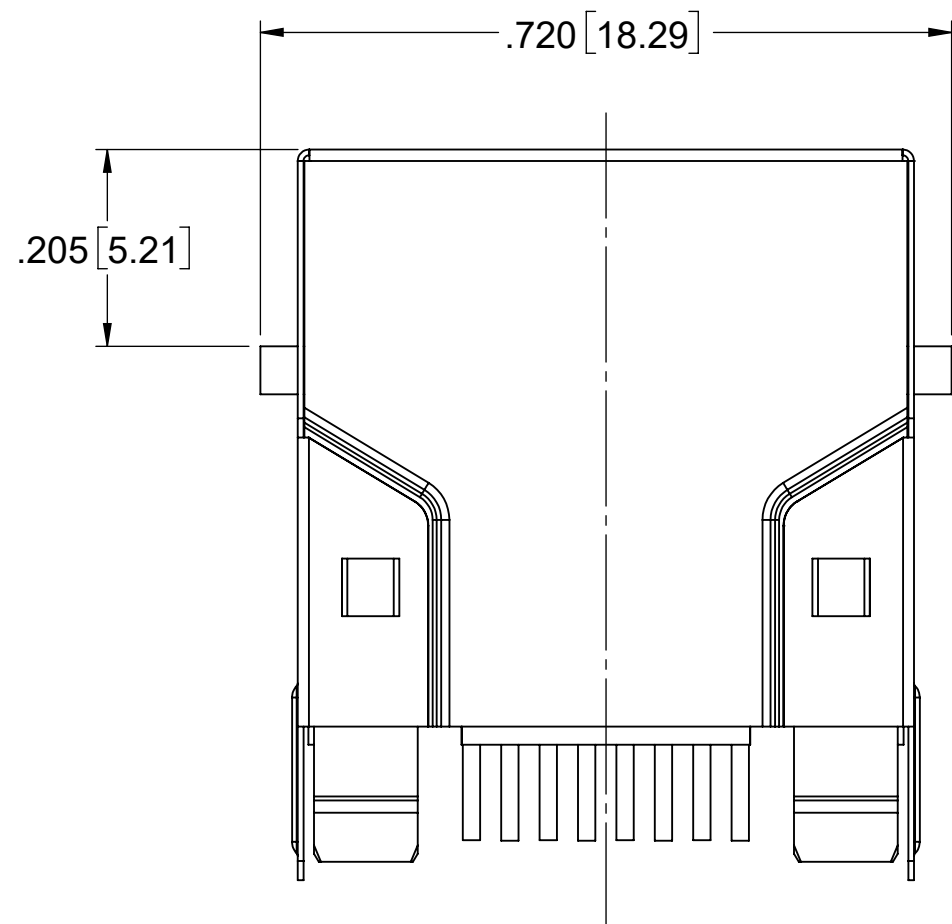

MATERIALS:

PLASTIC HOUSING: HIGH TEMPERATURE THERMOPLASTIC
 FLAMMABILITY RATING UL 94V-0, COLOR: BLACK

CONTACTS: PHOSPHOR BRONZE
 PLATING: 30 u" [0.76 MICRONS]
 MIN. GOLD ON MATING SURFACES.
 50 u" [1.27 MICRONS]
 MIN. NICKEL UNDERPLATE
 100 u" [2.54 MICRONS]
 MIN. MATTE TIN ON CONTACT TAILS.

SHIELD: STAINLESS STEEL WITH TIN FINISHED ON SOLDER TAILS.

RECOMMENDED SOLDERING TEMPERATURE:
 WAVE SOLDERING TEMPERATURE AT 260 °C MAXIMUM
 FOR 5 SEC MAXIMUM.

AMPHENOL PART NUMBER: RJHSE-3380

UNLESS SPECIFIED OTHERWISE	DRAWN	W.QIU	SEP26/21
PRIMARY UNITS INCHES	CHECKED	KELVIN.T	SEP26/21
SECONDARY MILLIMETERS	M.E. APP'D		
REFERENCE IN PARENTHESES	Q.A. APP'D		
GENERAL TOLERANCES	DWG APPR.	L.CHAN	SEP26/21
1 DECIMAL PLACE ±0.025	ENG. REL. NO.		
2 DECIMAL PLACES ±0.020	REF.		
3 DECIMAL PLACES ±0.015	THIRD ANGLE PROJECTION		
ANGULAR DEGREES ±1.5°	DO NOT SCALE DRAWING		

Amphenol Canada Corp.
 Commercial Products

MODULAR JACK, RJ45, SINGLE PORT, VERTICAL MOUNT, 8P8C, WITHOUT LEDS- RoHS COMPLIANT

DWG. NO. **P-RJHSE-3380** REV **C**

CODE ID NO. 03554 DWG SIZE: X SCALE: 5:1 SHEET 1 OF 1