

# TL170C SILICON HALL-EFFECT SWITCH

D2408, DECEMBER 1977, REVISED APRIL 1988

- Magnetic-Field Sensing Hall-Effect Input
- On-Off Hysteresis
- Small Size
- Solid-State Technology
- Open-Collector Output

## description

The TL170C is a low-cost magnetically operated electronic switch that utilizes the Hall Effect to sense steady-state magnetic fields. Each circuit consists of a Hall-Effect sensor, signal conditioning and hysteresis functions, and an output transistor integrated into a monolithic chip. The outputs of these circuits can be directly connected to many different types of electronic components.

The TL170C is characterized for operation over the temperature range of 0°C to 70°C.

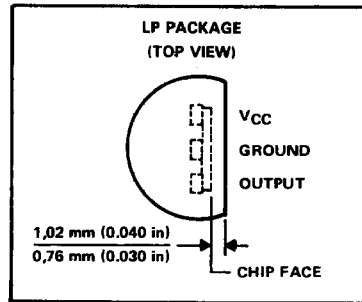

FUNCTION TABLE ( $T_A = 25^\circ\text{C}$ )

FLUX DENSITY	OUTPUT
$\leq -25 \text{ mT}$	Off
$-25 \text{ mT} < B < 25 \text{ mT}$	Undefined
$\geq 25 \text{ mT}$	On

## functional block diagram

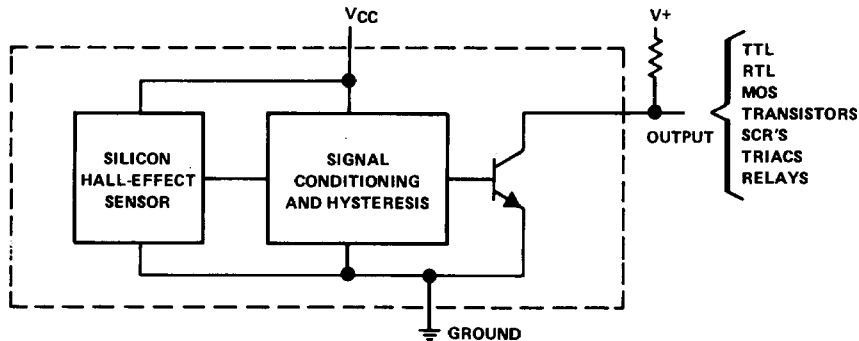

## absolute maximum ratings over operating free-air temperature range (unless otherwise noted)

Supply voltage, $V_{CC}$ (see Note 1)	7 V
Output voltage	30 V
Output current	20 mA
Operating free-air temperature range	0°C to 70°C
Storage temperature range	-65°C to 150°C
Lead temperature 1.6 mm (1/16 inch) from case for 10 seconds	260°C
Magnetic flux density	unlimited

NOTE 1. Voltage values are with respect to network ground terminal.

4

Special Functions

PRODUCTION DATA documents contain information current as of publication date. Products conform to specifications per the terms of Texas Instruments standard warranty. Production processing does not necessarily include testing of all parameters.

TEXAS  
INSTRUMENTS

POST OFFICE BOX 855012 • DALLAS, TEXAS 75265

Copyright © 1979, Texas Instruments Incorporated

4-121

# TL170C SILICON HALL-EFFECT SWITCH

electrical characteristics at specified free-air temperature,  $V_{CC} = 5\text{ V} \pm 5\%$  (unless otherwise noted)

PARAMETER	TEST CONDITIONS	MIN	TYP	MAX	UNIT	
$B_{T+}$	Threshold of positive-going magnetic flux density <sup>1</sup>	25 °C		25	mT <sup>‡</sup>	
		0 °C to 70 °C		35		
$B_{T-}$	Threshold of negative-going magnetic flux density <sup>1</sup>	25 °C		-25 <sup>§</sup>	mT <sup>‡</sup>	
		0 °C to 70 °C		-35 <sup>§</sup>		
$B_{T+} - B_{T-}$	Hysteresis		20		mT <sup>‡</sup>	
$I_{OH}$	High-level output current	$V_{OH} = 20\text{ V}$		100	$\mu\text{A}$	
$V_{OL}$	Low-level output voltage	$V_{CC} = 4.75\text{ V}$ , $I_{OL} = 16\text{ mA}$		0.4	V	
$I_{CC}$	Supply current	$V_{CC} = 5.25\text{ V}$	Output low		6	mA
			Output high		4	

<sup>1</sup> Threshold values are those levels of magnetic flux density at which the output changes state. For the TL170C, a level more positive than  $B_{T+}$  causes the output to go to a low level and a level more negative than  $B_{T-}$  causes the output to go to a high level. See Figures 1 and 2.

<sup>‡</sup> The unit of magnetic flux density in the International System of Units (SI) is the tesla (T). The tesla is equal to one weber per square meter. Values expressed in milliteslas may be converted to gauss by multiplying by ten.

<sup>§</sup> The algebraic convention, where the most negative limit is designated as minimum, is used in this data sheet for flux-density threshold levels only.

The north pole of a magnet is the pole that is attracted by the geographical north pole. The north pole of a magnet repels the north-seeking pole of a compass. By accepted magnetic convention, lines of flux emanate from the north pole of a magnet and enter the south pole.

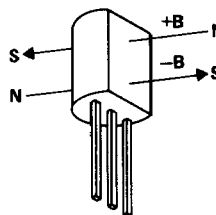
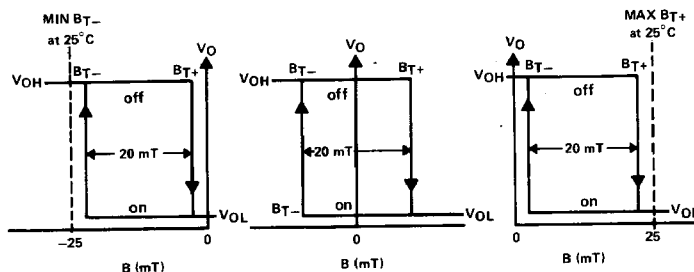

FIGURE 1. DEFINITION OF MAGNETIC FLUX POLARITY

4

Special Functions



The positive-going threshold ( $B_{T+}$ ) may be a negative or positive B level at which a positive-going (decreasing negative or increasing positive) flux density results in the TL170 output turn-on. The negative-going threshold is a positive or negative B level at which a negative-going (decreasing positive or increasing negative) flux density results in the TL170 turning off.

FIGURE 2. REPRESENTATIVE CURVES OF  $V_O$  vs B