

11 mm Square Encoders with Push-lock

Japan
Malaysia

Type: **EVQWEB/EVQWEG**

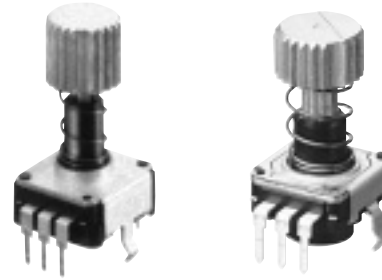

■ Features

- Encoder with a push-lock switch
(Normally: ON, When push-locked: OFF)
- Travel: 9.0 mm–8.0 mm
- 15 pulses, 30 detents

■ Recommended Applications

- Volume control or mode switches for car audio equipment
- Signal input for monitors and audio/visual equipment

■ Explanation Part Numbers

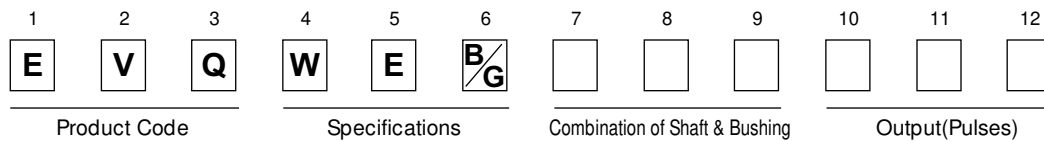

■ Specifications

Mechanical	Rotation Angle	360 ° (Endless)
	Shaft Pull/Push Strength	100 N min.
	Shaft Wobble	1.4×L/30 (mm) max.
	Rotation Torque	3 mN·m to 20 mN·m
	Detents	30 points
Electrical	Output Signal	A and B (2 phases)
	Resolution	15 pulses/360 °
	Rating	20 mA 16 Vdc
	Contact Resistance	1 mΩ max.
	Insulation Resistance	50 MΩ min. (at 250 Vdc)
	Dielectric Withstanding Voltage	300 Vac for 1 minute
	Bouncing	5 ms max.
Endurance	Rotation Life (Encoder)	30000 cycles min.
	Operating Life (Push-lock)	30000 cycles min.
Minimum Quantity/Packing Unit		100 pcs. (Tray Pack)
Quantity/Carton		500 pcs.

■ Dimensions in mm (not to scale)

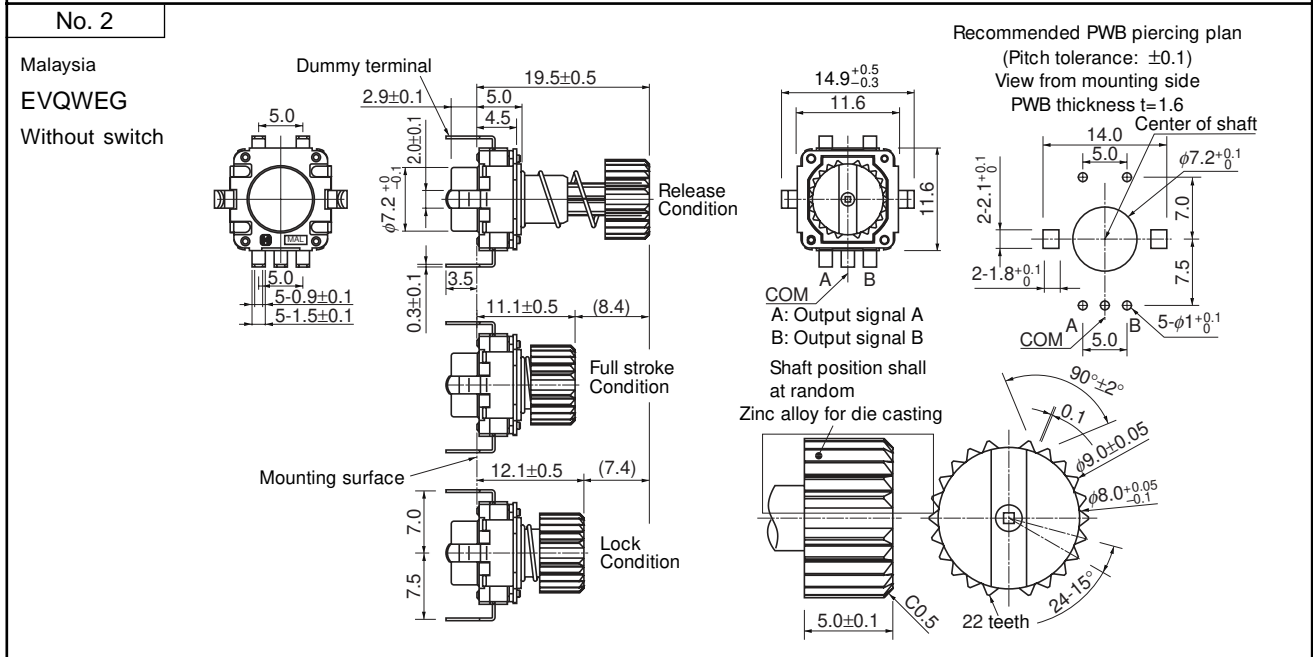
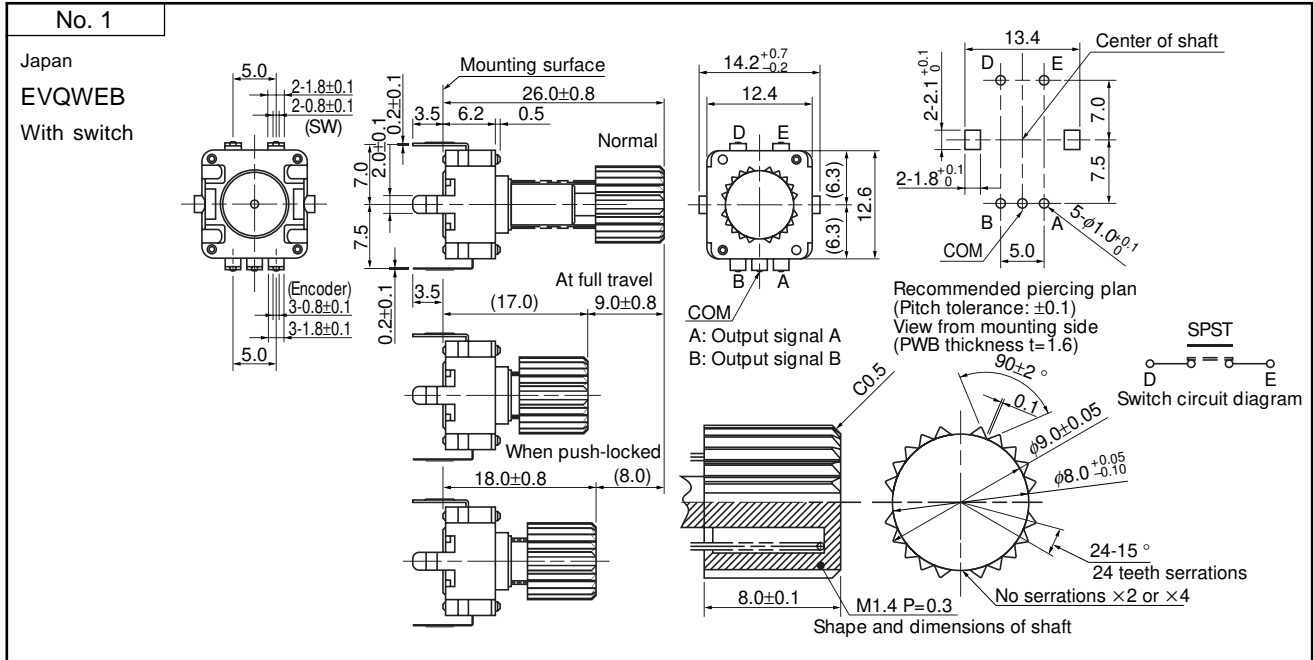

■ Phase Difference

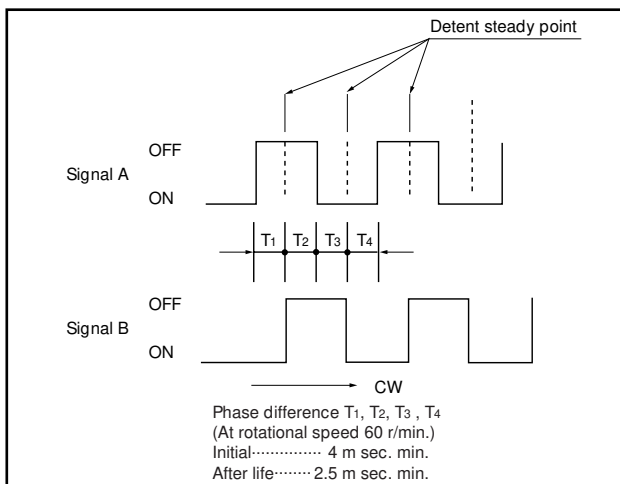

■ Test Circuit Diagram

