

4-bit dual supply level translator without direction control pin

Features

- 42 MHz: 84 Mbps (max) data rate at $V_L = 1.8\text{ V}$, $V_{CC} = 3.3\text{ V}$
- Bidirectional level translation without direction control pin
- Wide voltage range ($V_{CC} \geq V_L$):
 - V_L ranges from 1.65 to 3.6 V
 - V_{CC} ranges from 1.65 to 5.5 V
- Power down mode feature - when V_{CC} supply is off, all I/Os are in high impedance
- Totem-pole driving
- 5.5 V tolerant enable pin
- ESD performance on all pins : $\pm 2\text{ kv HBM}$
- Small package and footprint QFN16 (2.6 x 1.8 mm) package

Applications

- Low voltage system level translation
- Mobile phone and other mobile devices

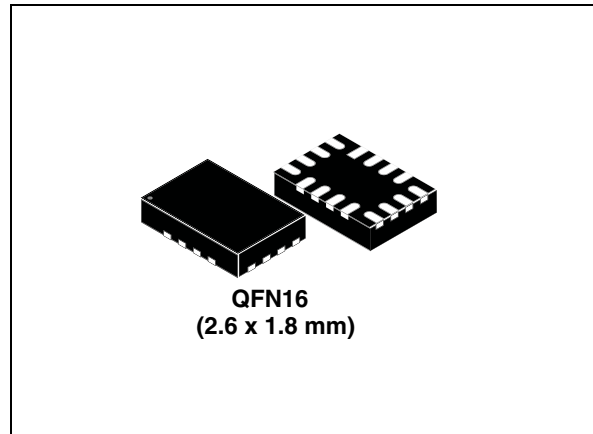

Description

The ST2149 is a 4-bit dual supply level translator which provides the level shifting capability to allow data transfer in a multi-voltage system. Externally applied voltages, V_{CC} and V_L , set the logic levels on either side of the device. Its architecture allows bidirectional level translation without a control pin.

The ST2149 accepts V_L from 1.65 to 3.6 V and V_{CC} from 1.65 to 5.5V, making it ideal for data transfer between low-voltage ASICs/PLD and higher voltage systems. This device has a tri-state output mode which can be used to disable all I/Os.

The ST2149 supports power-down mode when V_{CC} is grounded/floating or when the device is disabled via the OE pin.

Table 1. Device summary

Order code	Package	Packaging
ST2149QTR	QFN16 (2.6 x 1.8 mm)	Tape & reel (3000 parts per reel)

1 Pin settings

1.1 Pin connection

Figure 1. Pin connection (top through view)

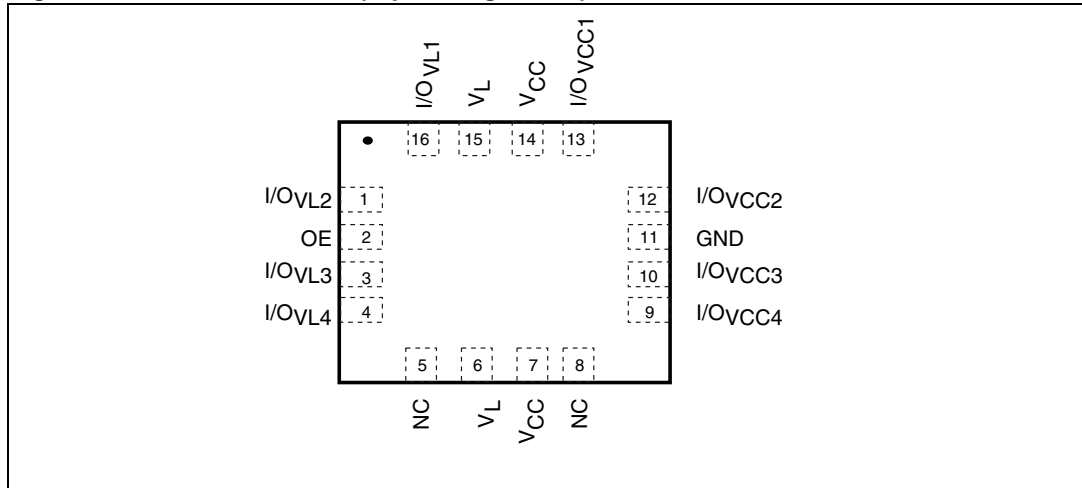

1.2 Pin description

Table 2. Pin description

Pin number	Symbol	Name and function
1	I/O _{VL2}	Data input/output
2	OE	Output enable
3	I/O _{VL3}	Data input/output
4	I/O _{VL4}	Data input/output
5	NC	No connection
6	V _L	Supply voltage
7	V _{CC}	Supply voltage
8	NC	No connection
9	I/O _{VCC4}	Data input/output
10	I/O _{VCC3}	Data input/output
11	GND	Ground
12	I/O _{VCC2}	Data input/output
13	I/O _{VCC1}	Data input/output
14	V _{CC}	Supply voltage
15	V _L	Supply voltage
16	I/O _{VL1}	Data input/output

2 Logic diagram

Figure 2. Logic block diagram

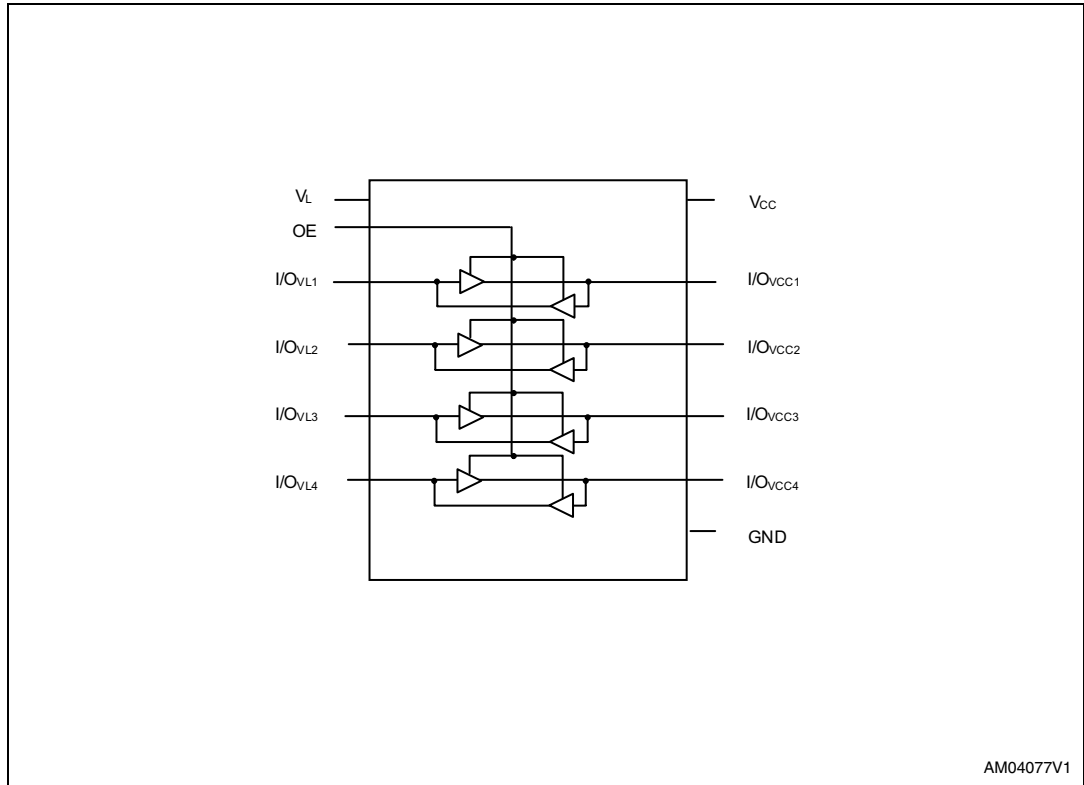

2.1 Device block diagrams

Figure 3. ST2149 block diagram

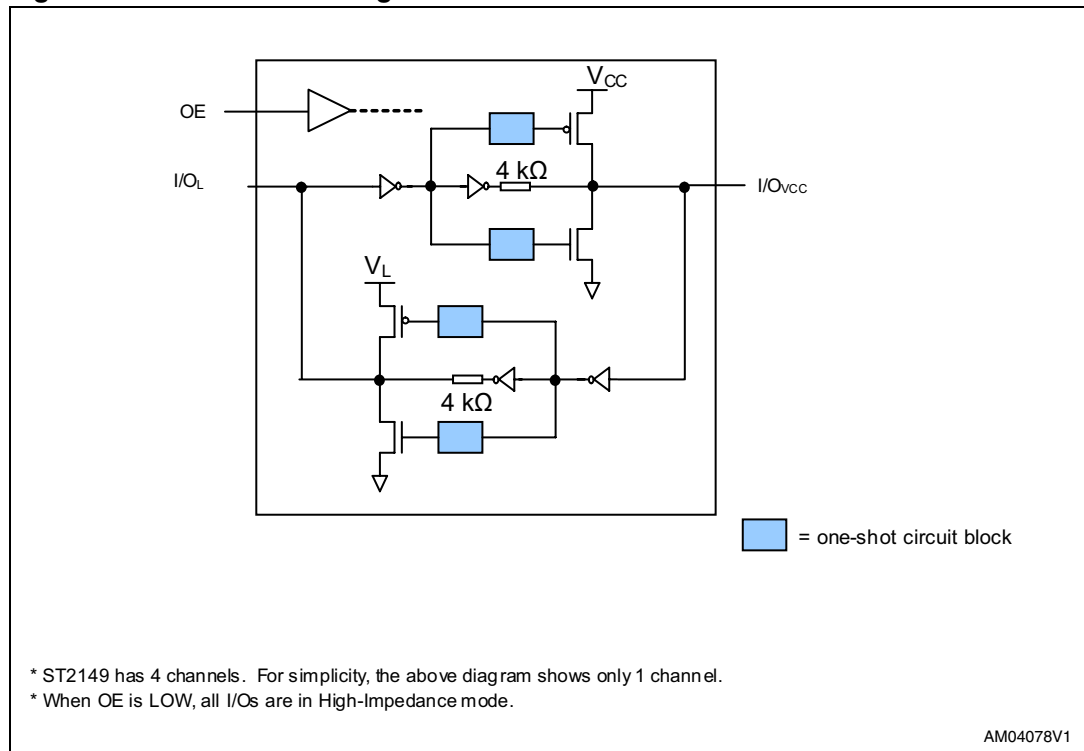
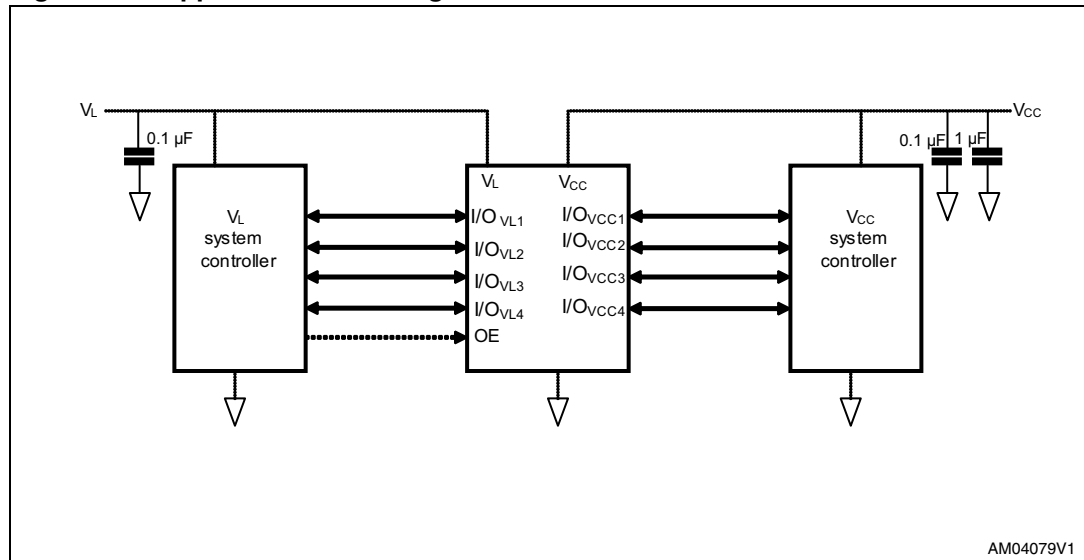

Figure 4. Application block diagram



3 Supplementary notes

3.1 Driver requirement

For proper operation, the driver from each side of the device must have capability to source and sink a minimum of 1 mA current. The device architecture requires the driver to source/sink maximum current of $(V_{CC}/4)$ mA to/from the weak 4 k Ω output buffer.

3.2 Load driving capability

To support the architecture that allows level translation without direction pin, the one-shot transistor is turned ON only during state transition at the output side. After the one-shot transistor is turned OFF, only the 4k Ω resistor will maintain the state. So, resistive load or pull-up resistor less than 50k Ω is not recommended for proper operation.

3.3 Power off feature

In some application where it might be required to turn off one of the power supplies powering up the level translator. The device will be automatically disabled when V_{CC} supply is turned OFF, even if the OE pin is set to HIGH (enabled). In this mode, all I/Os are in high impedance state.

3.4 Truth table

Table 3. Truth table

Enable	Bidirectional Input/Output	
	I/O _{VCC}	I/O _{VL}
H ⁽¹⁾	H ⁽²⁾	H ⁽¹⁾
H ⁽¹⁾	L	L
L	Z ⁽³⁾	Z ⁽³⁾

1. High level V_L power supply referred.
2. High level V_{CC} power supply referred.
3. Z = High impedance.

4 Maximum ratings

Stressing the device above the rating listed in [Table 4](#) may cause permanent damage to the device. These are stress ratings only and operation of the device at these or any other conditions above those indicated in the operating sections of this specification is not implied. Exposure to absolute maximum rating conditions for extended periods may affect device reliability.

Table 4. Absolute maximum ratings

Symbol	Parameter	Value	Unit
V_L	Supply voltage	-0.3 to 4.6	V
V_{CC}	Supply voltage	-0.3 to 6.5	V
V_{OE}	DC control input voltage	-0.3 to 6.5	V
$V_{I/OVL}$	DC I/O _{VL} input voltage (OE = GND or V_L)	-0.3 to $V_L + 0.3$	V
$V_{I/OVCC}$	DC I/O _{VCC} input voltage (OE = GND or V_L)	-0.3 to $V_{CC} + 0.3$	V
I_{IK}	DC input diode current	-20	mA
$I_{I/OVL}$	DC output current	±25	mA
$I_{I/OVCC}$	DC output current	±258	mA
I_{SCTOUT}	Short circuit duration, continuous	40	mA
P_D	Power dissipation	500	mW
T_{STG}	Storage temperature	-65 to 150	°C
T_L	Lead temperature (10 seconds)	300	°C
ESD	Electrostatic discharge protection (HBM)	±2	kV

4.1 Recommended operating conditions

Table 5. Recommended operating conditions

Symbol	Parameter	Min.	Typ.	Max.	Unit
V_L	Supply voltage	1.65	–	3.6	V
V_{CC}	Supply voltage	1.65	–	5.5	V
V_{OE}	Input voltage (OE output enable pin, V_L power supply referred)	0	–	3.6	V
$V_{I/OVL}$	I/O _{VL} voltage	0	–	V_L	V
$V_{I/OVCC}$	I/O _{VCC} voltage	0	–	V_{CC}	V
T_{OP}	Operating temperature	-40	–	85	°C
dt/dV	Input rise and fall time	0	–	1	ns/V

5 Electrical characteristics

Over recommended operating conditions unless otherwise noted. All typical values are at $T_A = 25\text{ }^\circ\text{C}$.

Table 6. DC characteristics

Symbol	Parameter	V_L	V_{CC}	Test conditions	Value					Unit
					$T_A = 25\text{ }^\circ\text{C}$			$-40\text{ to }85\text{ }^\circ\text{C}$		
					Min	Typ	Max	Min	Max	
V_{IHL}	High level input voltage (I/O_{VL})	1.65	1.65 to 5.5		1.16	–	–	1.16	–	V
		1.8			1.26	–	–	1.26	–	
		2.5			1.75	–	–	1.75	–	
		3.0			2.10	–	–	2.10	–	
		3.6			2.52	–	–	2.52	–	
V_{ILL}	Low level input voltage (I/O_{VL})	1.65	1.65 to 5.5		–	–	0.50	–	0.50	V
		1.8			–	–	0.54	–	0.54	
		2.5			–	–	0.75	–	0.75	
		3.0			–	–	0.90	–	0.90	
		3.6			–	–	1.08	–	1.08	
V_{IHC}	High level input voltage (I/O_{VCC})	1.65 to 3.6	1.65		1.16	–	–	1.16	–	V
			1.8		1.26	–	–	1.26	–	
			2.5		1.75	–	–	1.75	–	
			3.0		2.10	–	–	2.10	–	
			3.6		2.52	–	–	2.52	–	
			4.3		3.01	–	–	3.01	–	
			5.5		3.85	–	–	3.85	–	
V_{ILC}	Low level input voltage (I/O_{VCC})	1.65 to 3.6	1.65		–	–	0.50	–	0.50	V
			1.8		–	–	0.54	–	0.54	
			2.5		–	–	0.75	–	0.75	
			3.0		–	–	0.90	–	0.90	
			3.6		–	–	1.08	–	1.08	
			4.3		–	–	1.29	–	1.29	
			5.5		–	–	1.65	–	1.65	

Table 6. DC characteristics (continued)

Symbol	Parameter	V _L	V _{CC}	Test conditions	Value					Unit
					T _A = 25 °C			-40 to 85 °C		
					Min	Typ	Max	Min	Max	
V _{IH-OE}	High level input voltage (OE)	1.65	1.65 to 5.5		1.16	–	–	1.16	–	V
		1.8			1.26	–	–	1.26	–	
		2.5			1.75	–	–	1.75	–	
		3.0			2.10	–	–	2.10	–	
		3.6			2.52	–	–	2.52	–	
V _{IL-OE}	Low level input voltage (OE)	1.65	1.65 to 5.5		–	–	0.50	–	0.50	V
		1.8			–	–	0.54	–	0.54	
		2.5			–	–	0.75	–	0.75	
		3.0			–	–	0.90	–	0.90	
		3.6			–	–	1.08	–	1.08	
V _{OHL}	High level output voltage (I/O _{VL})	1.65 to 3.6	1.65 to 5.5	IO = -60 μA	V _L - 0.4	–	–	V _L - 0.4	–	V
V _{OLL}	Low level output voltage (I/O _{VL})	1.65 to 3.6	1.65 to 5.5	IO = +60 μA	–	–	0.4	–	0.4	V
V _{OHC}	High level output voltage (I/O _{VCC})	1.65 to 3.6	1.65 to 5.5	IO = -60 μA	V _{CC} - 0.4	–	–	V _{CC} - 0.4	–	V
V _{OLC}	Low level output voltage (I/O _{VCC})	1.65 to 3.6	1.65 to 5.5	IO = +60 μA	–	–	0.4	–	0.4	V
I _{OE}	Control input leakage current (OE)	1.65 to 3.6	1.65 to 5.5	V _I = GND or V _L	–	–	0.1	–	1	μA
I _{IO_LKG}	High impedance leakage current (I/O _{VL} , I/O _{VCC})	1.65 to 3.6	1.65 to 5.5	OE = GND I/O _{VL} = High I/O _{VCC} = Low	–	–	0.1	–	1	μA
				OE = GND I/O _{VL} = Low I/O _{VCC} = High	–	–	0.1	–	1	μA

Table 6. DC characteristics (continued)

Symbol	Parameter	V_L	V_{CC}	Test conditions	Value					Unit
					$T_A = 25\text{ }^\circ\text{C}$			$-40\text{ to }85\text{ }^\circ\text{C}$		
					Min	Typ	Max	Min	Max	
I_{OFF}	Partial power down current	1.65 to 3.6	0	OE = V_L or GND I/O $_{VL}$ = High I/O $_{VCC}$ = Low	–	–	0.1	–	1	μA
				OE = V_L or GND I/O $_{VL}$ = Low I/O $_{VCC}$ = High	–	–	0.1	–	1	
I_{QVCC}	Quiescent supply current V_{CC}	1.65 to 3.6	1.65 to 5.5	OE = V_L I/O = Hi-Z	–	–	7	–	9	μA
I_{QVL}	Quiescent supply current V_L	1.65 to 3.6	1.65 to 5.5	OE = V_L I/O = Hi-Z	–	–	0.1	–	1	μA
		1.65 to 3.6	0		–	–	0.1	–	1	
I_{Z-VCC}	High impedance quiescent supply current V_{CC}	1.65 to 3.6	1.65 to 5.5	OE = GND I/O = Hi-Z	–	–	0.1	–	1	μA
I_{Z-VL}	High impedance quiescent supply current V_L	1.65 to 3.6	1.65 to 5.5	OE = GND I/O = Hi-Z	–	–	0.1	–	1	μA
		1.65 to 3.6	0		–	–	0.1	–	1	

5.1 AC characteristics

Load $C_L = 15$ pF; driver $t_r = t_f \leq 2$ ns over temperature range -40 °C to 85 °C.

Table 7. AC characteristics - test conditions: $V_L = 1.65 - 1.95$ V

Symbol	Parameter	$V_{CC} = 1.65 - 1.95$ V		$V_{CC} = 2.3 - 2.7$ V		$V_{CC} = 3.0 - 3.6$ V		$V_{CC} = 4.5 - 5.5$ V		Unit	
		Min	Max	Min	Max	Min	Max	Min	Max		
t_{RVCC}	Rise time I/O_{VCC}	–	5.0	–	3.2	–	2.4	–	1.4	ns	
t_{FVCC}	Fall time I/O_{VCC}	–	1.5	–	1.4	–	1.3	–	1.2	ns	
t_{RVL}	Rise time I/O_{VL}	–	2.8	–	2.7	–	2.6	–	2.6	ns	
t_{FVL}	Fall time I/O_{VL}	–	1.5	–	1.4	–	1.4	–	1.3	ns	
$t_{I/O_{VL-VCC}}$	Propagation delay time I/O_{VL-LH} to I/O_{VCC-LH} I/O_{VL-HL} to I/O_{VCC-HL}	t_{PLH}	–	6.6	–	5.8	–	5.0	–	4.4	ns
		t_{PHL}	–	4.1	–	3.8	–	3.6	–	3.4	ns
$t_{I/O_{VCC-VL}}$	Propagation delay time I/O_{VCC-LH} to I/O_{VL-LH} I/O_{VCC-HL} to I/O_{VL-HL}	t_{PLH}	–	4.9	–	4.4	–	4.1	–	4.4	ns
		t_{PHL}	–	4.6	–	4.2	–	4.0	–	3.6	ns
t_{PZL} t_{PZH}	Output enable time	–	27	–	27	–	27	–	27	ns	
t_{PLZ} t_{PHZ}	Output disable time	–	145	–	145	–	145	–	145		
D_R	Data rate ⁽¹⁾	41	–	66	–	84	–	86	–	Mbps	

1. Data rate is guaranteed based on the condition that output I/O signal rise/fall -time is less than 15% of period of input I/O signal; input I/O signal is at 50% duty-cycle and output I/O signal duty-cycle deviation is less than $50\% \pm 10\%$.

Table 8. AC characteristics - test conditions: $V_L = 2.3 - 2.7 V$

Symbol	Parameter	$V_{CC} = 2.3 - 2.7 V$		$V_{CC} = 3.0 - 3.6 V$		$V_{CC} = 4.5 - 5.5 V$		Unit	
		Min	Max	Min	Max	Min	Max		
t_{RVCC}	Rise time I/O_{VCC}	-	3.3	-	2.2	-	1.6	ns	
t_{FVCC}	Fall time I/O_{VCC}	-	1.7	-	1.6	-	1.4	ns	
t_{RVL}	Rise time I/O_{VL}	-	2.2	-	2.0	-	1.9	ns	
t_{FVL}	Fall time I/O_{VL}	-	1.3	-	1.2	-	1.2	ns	
$t_{I/OVL-VCC}$	Propagation delay time I/O_{VL-LH} to I/O_{VCC-LH}	t_{PLH}	-	4.6	-	4.3	-	3.9	ns
	I/O_{VL-HL} to I/O_{VCC-HL}	t_{PHL}	-	3.6	-	3.3	-	2.9	ns
$t_{I/OVCC-VL}$	Propagation delay time I/O_{VCC-LH} to I/O_{VL-LH}	t_{PLH}	-	3.9	-	3.5	-	3.5	ns
	I/O_{VCC-HL} to I/O_{VL-HL}	t_{PHL}	-	3.6	-	3.0	-	2.5	ns
t_{PZL} t_{PZH}	Output enable time	-	20	-	20	-	20	ns	
t_{PLZ} t_{PHZ}	Output disable time	-	130	-	130	-	130		
D_R	Data rate ⁽¹⁾	84	-	85	-	88	-	Mbps	

1. Data rate is guaranteed based on the condition that output I/O signal rise/fall -time is less than 15% of period of input I/O signal; input I/O signal is at 50% duty-cycle and output I/O signal duty-cycle deviation is less than $50\% \pm 10\%$.

Table 9. AC characteristics - test conditions: $V_L = 3.0 - 3.6 V$

Symbol	Parameter	$V_{CC} = 3.0 - 3.6 V$		$V_{CC} = 4.5 - 5.5 V$		Unit	
		Min	Max	Min	Max		
t_{RVCC}	Rise time I/O_{VCC}	-	1.8	-	1.7	ns	
t_{FVCC}	Fall time I/O_{VCC}	-	1.3	-	1.2	ns	
t_{RVL}	Rise time I/O_{VL}	-	1.6	-	1.5	ns	
t_{FVL}	Fall time I/O_{VL}	-	1.1	-	1.1	ns	
$t_{I/OVL-VCC}$	Propagation delay time I/O_{VL-LH} to I/O_{VCC-LH}	t_{PLH}	-	4.1	-	4.1	ns
	I/O_{VL-HL} to I/O_{VCC-HL}	t_{PHL}	-	2.6	-	2.3	ns
$t_{I/OVCC-VL}$	Propagation delay time I/O_{VCC-LH} to I/O_{VL-LH}	t_{PLH}	-	4.0	-	4.0	ns
	I/O_{VCC-HL} to I/O_{VL-HL}	t_{PHL}	-	2.6	-	2.4	ns
t_{PZL} t_{PZH}	Output enable time	-	15	-	15	ns	
t_{PLZ} t_{PHZ}	Output disable time	-	110	-	110		
D_R	Data rate ⁽¹⁾	86	-	89	-	Mbps	

1. Data rate is guaranteed based on the condition that output I/O signal rise/fall -time is less than 15% of period of input I/O signal; input I/O signal is at 50% duty-cycle and output I/O signal duty-cycle deviation is less than $50\% \pm 10\%$.

6 Test circuit

Figure 5. Test circuit

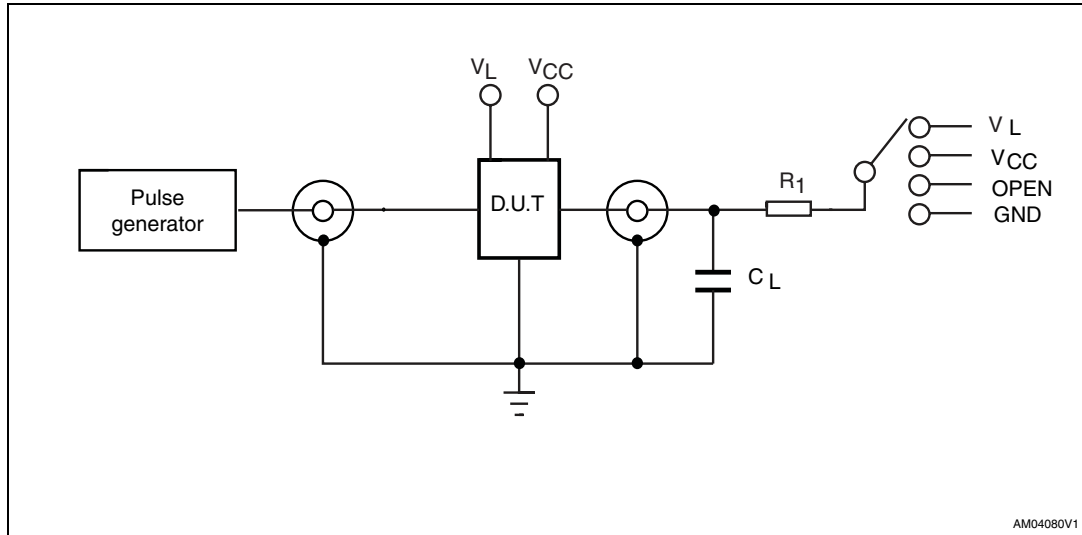

Table 10. Test circuit switches

Test	C_L	R_1	Switch
t_{PLH}, t_{PHL}	15 pF	20 k Ω	Open
t_r, t_f	15 pF	20 k Ω	Open
t_{PZL}, t_{PLZ}	15 pF	20 k Ω	V_L or V_{CC}
t_{PZH}, t_{PHZ}	15 pF	20 k Ω	GND

Table 11. Waveform symbol value

Symbol	Driving I/O V_L		Driving I/O V_{CC}	
	$1.65\text{ V} \leq V_L \leq V_{CC} \leq 2.5\text{ V}$	$3.3\text{ V} \leq V_L \leq V_{CC} \leq 5.5\text{ V}$	$1.65\text{ V} \leq V_L \leq V_{CC} \leq 2.5\text{ V}$	$3.3\text{ V} \leq V_L \leq V_{CC} \leq 5.5\text{ V}$
V_{IH}	V_L	V_L	V_{CC}	V_{CC}
V_{IM}	50% V_L	50% V_L	50% V_{CC}	50% V_{CC}
V_{OM}	50% V_{CC}	50% V_{CC}	50% V_L	50% V_L
V_X	$V_{OL} + 0.15\text{V}$	$V_{OL} + 0.3\text{V}$	$V_{OL} + 0.15\text{V}$	$V_{OL} + 0.3\text{V}$
V_Y	$V_{OH} - 0.15\text{V}$	$V_{OH} - 0.3\text{V}$	$V_{OH} - 0.15\text{V}$	$V_{OH} - 0.3\text{V}$

Figure 6. Waveform - propagation delay (f = 1 MHz, 50% duty cycle)

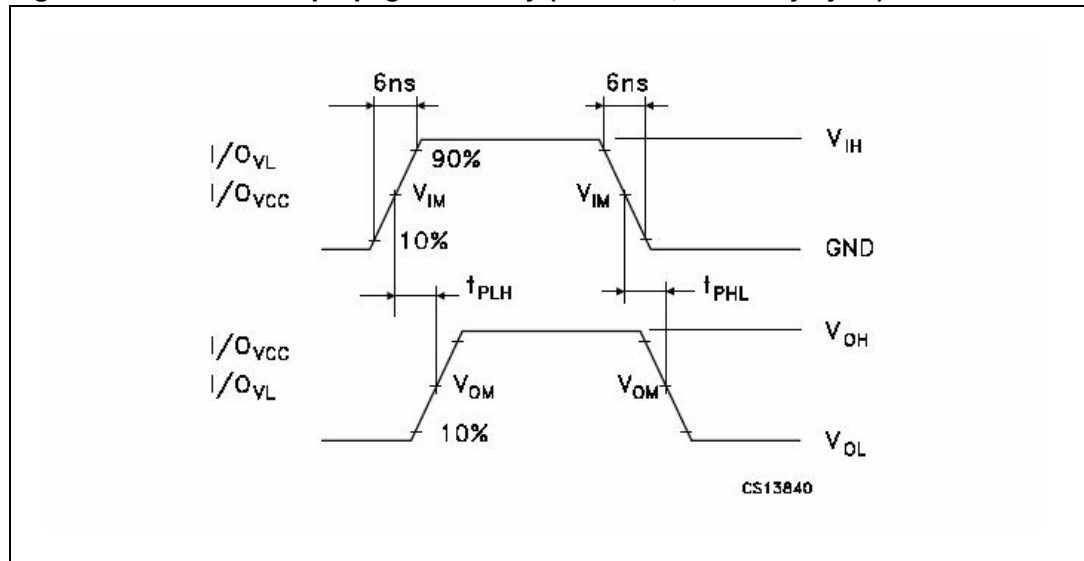
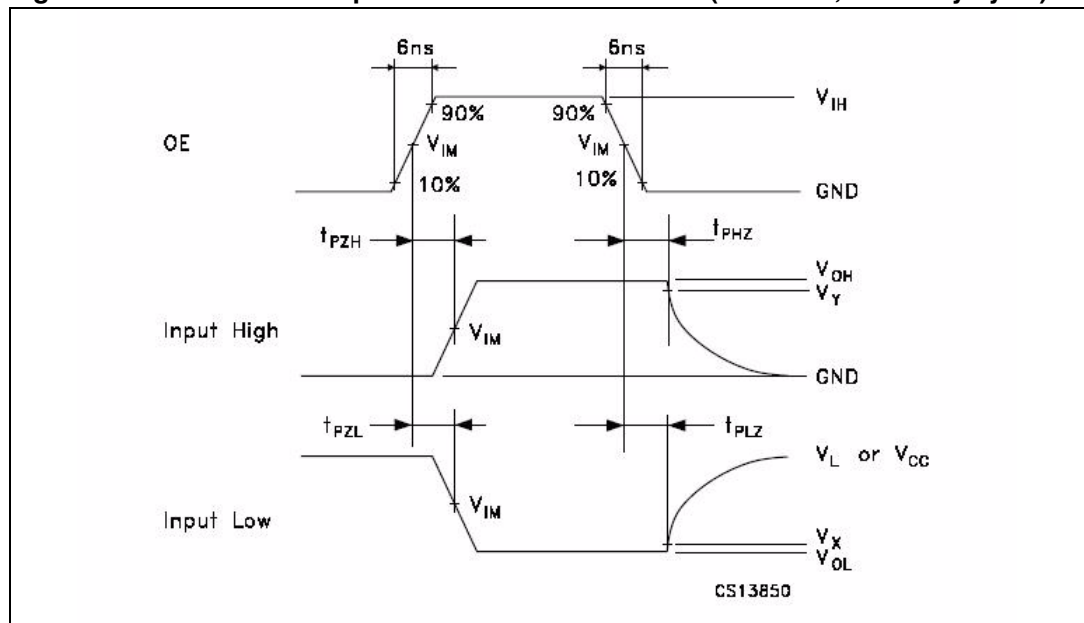

Figure 7. Waveform - output enable and disable time (f = 1 MHz, 50% duty cycle)



7 Package mechanical data

In order to meet environmental requirements, ST offers these devices in different grades of ECOPACK® packages, depending on their level of environmental compliance. ECOPACK® specifications, grade definitions and product status are available at: www.st.com. ECOPACK® is an ST trademark.

Figure 8. Package outline for QFN16 (2.6 x 1.8 x 0.55 mm) - 0.40 mm pitch

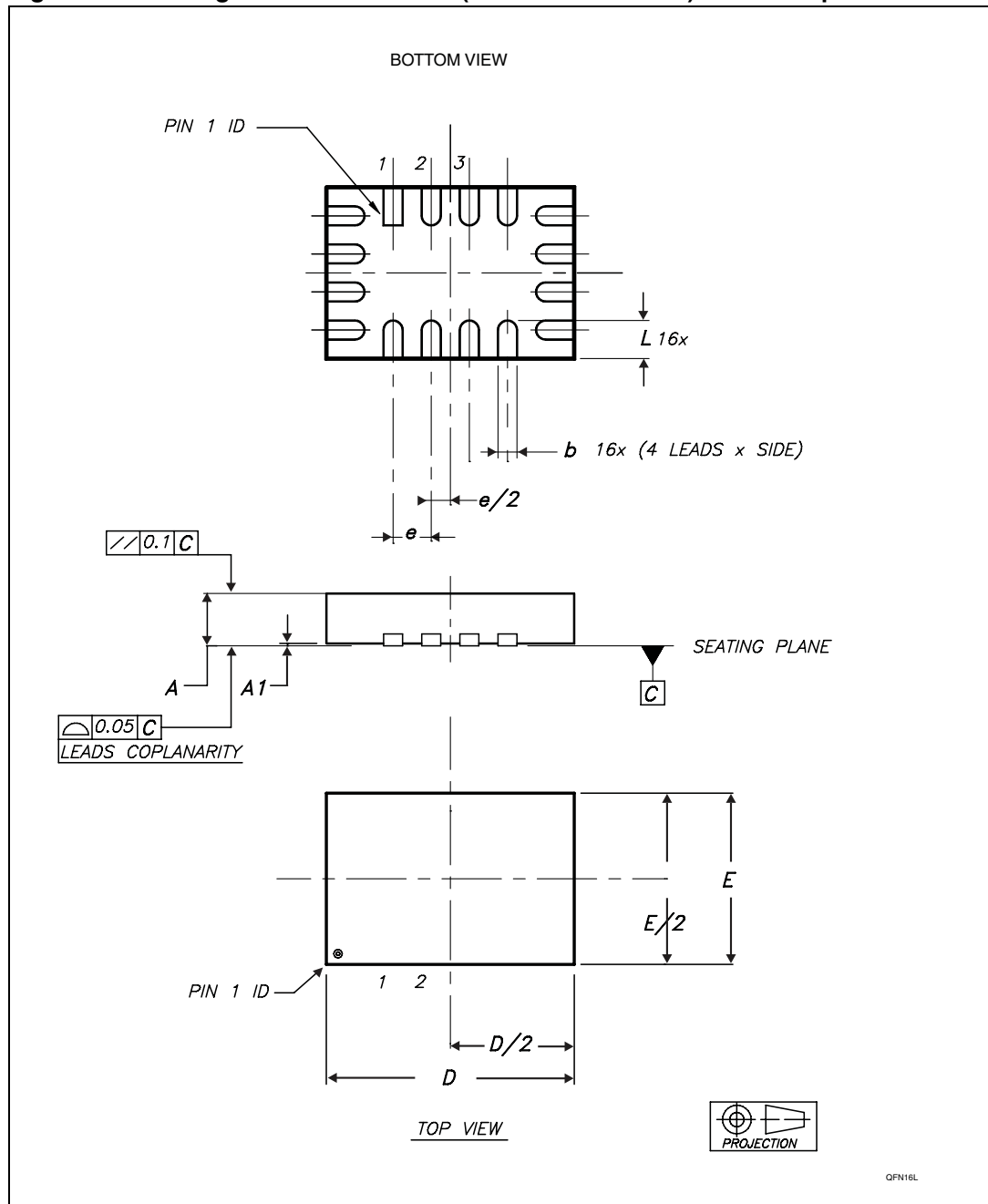

Table 12. Mechanical data for QFN16 (2.6 x 1.8 x 0.55 mm) - 0.40 mm pitch

Symbol	Millimeters		
	Typ	Min	Max
A	0.55	0.45	0.60
A1	0.02	0	0.05
b	0.20	0.15	0.25
D	2.60	2.50	2.70
E	1.80	1.70	1.90
e	0.40	-	-
L	0.40	0.35	0.45

Figure 9. Footprint recommendation for QFN16 (2.6 x 1.8 x 0.55 mm) - 0.40 mm pitch

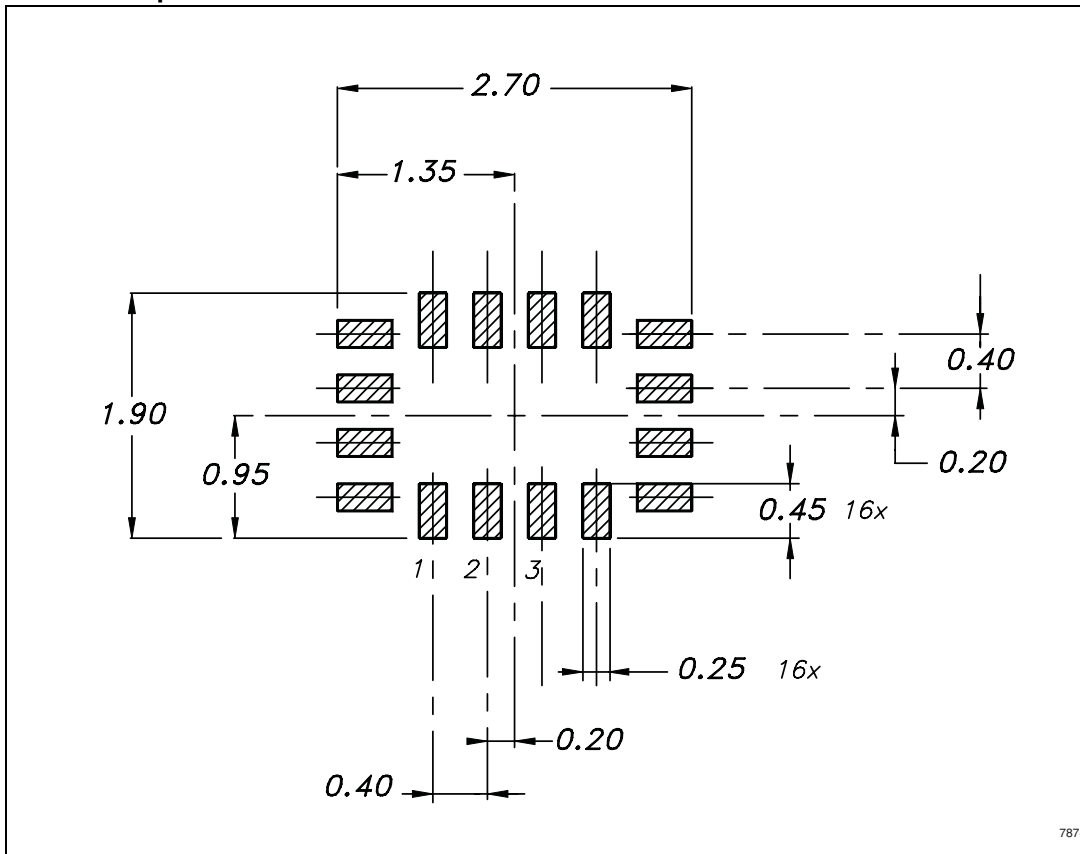

Figure 10. Carrier tape for QFN16 (2.6 x 1.8 x 0.55 mm) - 0.40 mm pitch

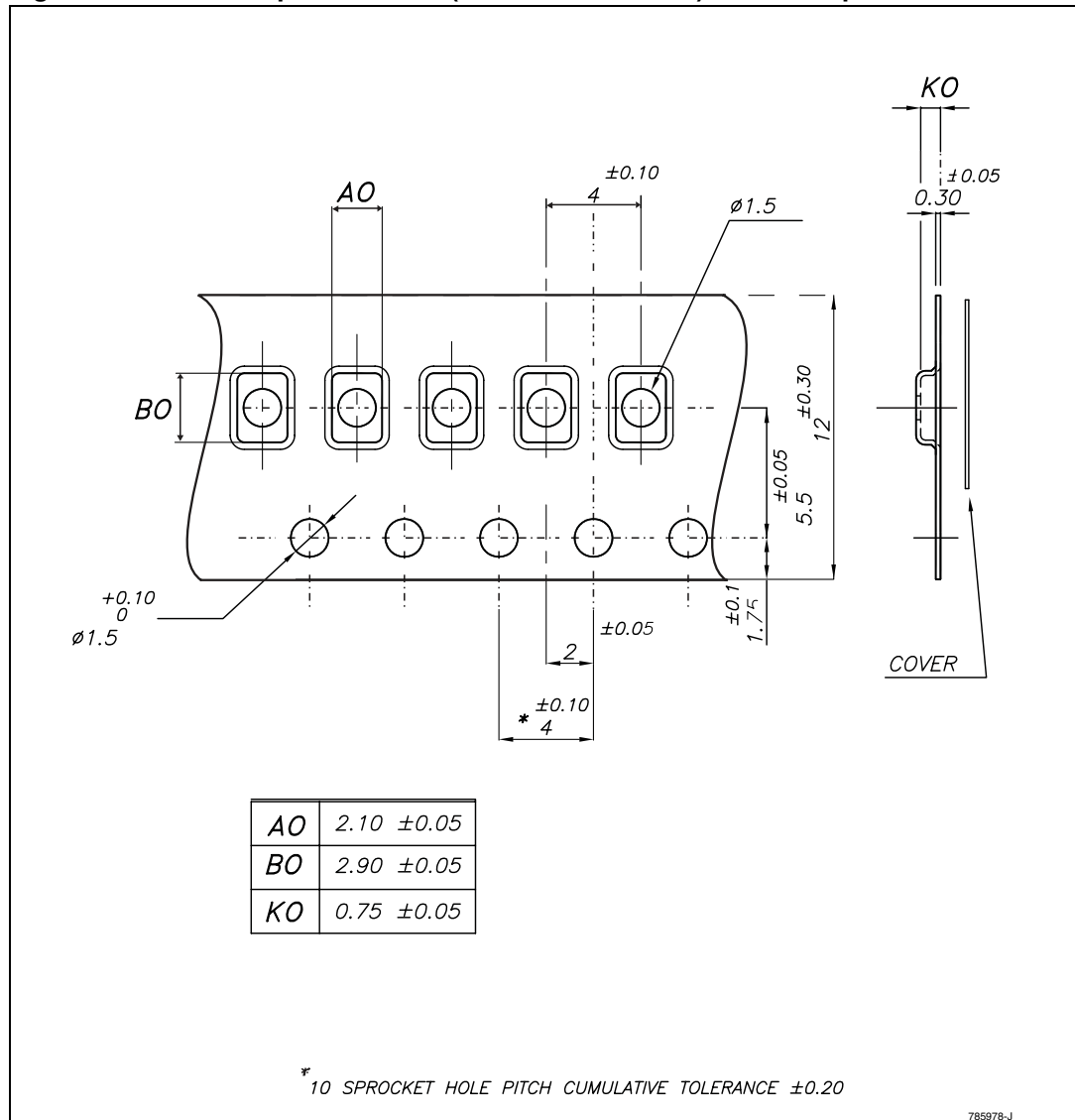
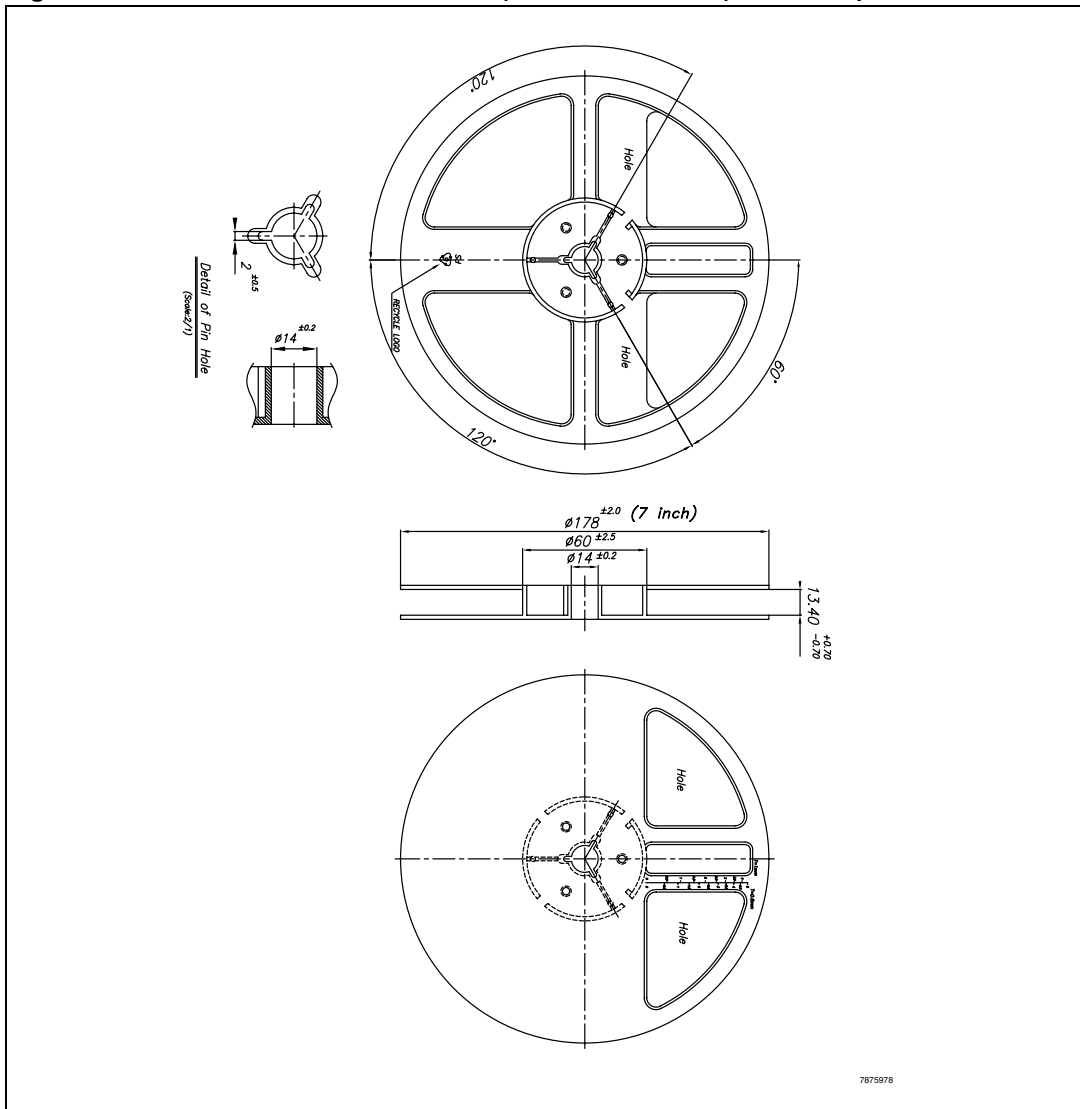

Figure 11. Reel information for QFN16 (2.6 x 1.8 x 0.55 mm) - 0.40 mm pitch



8 Revision history

Table 13. Document revision history

Date	Revision	Changes
07-Sep-2009	1	Initial release.

Please Read Carefully:

Information in this document is provided solely in connection with ST products. STMicroelectronics NV and its subsidiaries ("ST") reserve the right to make changes, corrections, modifications or improvements, to this document, and the products and services described herein at any time, without notice.

All ST products are sold pursuant to ST's terms and conditions of sale.

Purchasers are solely responsible for the choice, selection and use of the ST products and services described herein, and ST assumes no liability whatsoever relating to the choice, selection or use of the ST products and services described herein.

No license, express or implied, by estoppel or otherwise, to any intellectual property rights is granted under this document. If any part of this document refers to any third party products or services it shall not be deemed a license grant by ST for the use of such third party products or services, or any intellectual property contained therein or considered as a warranty covering the use in any manner whatsoever of such third party products or services or any intellectual property contained therein.

UNLESS OTHERWISE SET FORTH IN ST'S TERMS AND CONDITIONS OF SALE ST DISCLAIMS ANY EXPRESS OR IMPLIED WARRANTY WITH RESPECT TO THE USE AND/OR SALE OF ST PRODUCTS INCLUDING WITHOUT LIMITATION IMPLIED WARRANTIES OF MERCHANTABILITY, FITNESS FOR A PARTICULAR PURPOSE (AND THEIR EQUIVALENTS UNDER THE LAWS OF ANY JURISDICTION), OR INFRINGEMENT OF ANY PATENT, COPYRIGHT OR OTHER INTELLECTUAL PROPERTY RIGHT.

UNLESS EXPRESSLY APPROVED IN WRITING BY AN AUTHORIZED ST REPRESENTATIVE, ST PRODUCTS ARE NOT RECOMMENDED, AUTHORIZED OR WARRANTED FOR USE IN MILITARY, AIR CRAFT, SPACE, LIFE SAVING, OR LIFE SUSTAINING APPLICATIONS, NOR IN PRODUCTS OR SYSTEMS WHERE FAILURE OR MALFUNCTION MAY RESULT IN PERSONAL INJURY, DEATH, OR SEVERE PROPERTY OR ENVIRONMENTAL DAMAGE. ST PRODUCTS WHICH ARE NOT SPECIFIED AS "AUTOMOTIVE GRADE" MAY ONLY BE USED IN AUTOMOTIVE APPLICATIONS AT USER'S OWN RISK.

Resale of ST products with provisions different from the statements and/or technical features set forth in this document shall immediately void any warranty granted by ST for the ST product or service described herein and shall not create or extend in any manner whatsoever, any liability of ST.

ST and the ST logo are trademarks or registered trademarks of ST in various countries.

Information in this document supersedes and replaces all information previously supplied.

The ST logo is a registered trademark of STMicroelectronics. All other names are the property of their respective owners.

© 2009 STMicroelectronics - All rights reserved

STMicroelectronics group of companies

Australia - Belgium - Brazil - Canada - China - Czech Republic - Finland - France - Germany - Hong Kong - India - Israel - Italy - Japan - Malaysia - Malta - Morocco - Philippines - Singapore - Spain - Sweden - Switzerland - United Kingdom - United States of America

www.st.com

