

ECS-TXO-20CSMV Clipped Sine Wave SMD TCXO MultiVolt™ capability of 1.7 ~ 3.465V. The 2.0 x 1.6 x 0.8 mm ceramic package is ideal for portable, wireless applications where stability is critical.

[Request a Sample](#)

OPERATING CONDITIONS / ELECTRICAL CHARACTERISTICS



- Clipped Sine Wave TCXO
- 2.0 x 1.6 mm Footprint
- MultiVolt™ (1.7 ~ 3.465V)
- PbFree/RoHS Compliant
- MSL 1
- Lead Finish Au
- Compatible with 1.8V, 2.5V or 3.3V Power Supply

| Parameters | Conditions | ECS-TXO-20CSMV | | | Units |
|-----------------------|--------------------------------|----------------|------|--------|--------|
| | | MIN | TYP | MAX | |
| Frequency Range | | 10.000 | | 52.000 | MHz |
| Frequency Tolerance | @ +25°C ±2°C | | | ±2.0 | PPM |
| Frequency Stability | Vs. Temp (-40 ~ +85°C) BN Opt | | | ±1.0 | PPM |
| | Vs. Supply Change (±5%) | | | ±0.2 | PPM |
| | Vs. Load Change (±10%) | | | ±0.2 | PPM |
| | Vs. Aging 1 st Year | | | ±1.0 | PPM |
| Input Voltage | VDD | +1.7 | | +3.465 | VDC |
| Current Consumption | 10 ~ 26 MHz | | | 2.0 | mA |
| | 26.1 ~ 52 MHz | | | 2.5 | mA |
| Output Level | Clipped Sine Wave | 0.8 | | | V p-p |
| Output Load | | 10KΩ//10 pF | | | |
| Start-up Time | | | | 2 | mS |
| Phase Noise | @ 10 KHz Offset | | -145 | | dBc/Hz |
| Operating Temperature | * N Option | -40 | | +85 | °C |
| Storage Temperature | | -40 | | +90 | °C |

Part Numbering Guide: Example ECS-TXO-20CSMV-320-BN-TR

| ECS | Series | Frequency Abbreviations | Stability | Temperature | Packaging |
|-----|---|-------------------------|---|--|---------------------------------|
| ECS | TXO-20CSMV = Clipped Sine Wave TCXO | 260 = 26.000 MHz | A= ±0.5 ppm B= ±1.0 ppm C= ±1.5 ppm D= ±2.0 ppm E= ±2.5 ppm | L= -10 ~ +70°C M= -20 ~ +70°C Y= -30 ~ +85°C N= -40 ~ +85°C | TR = 1K TR3 = 3K Qty/Reel |

Package Dimensions (mm)

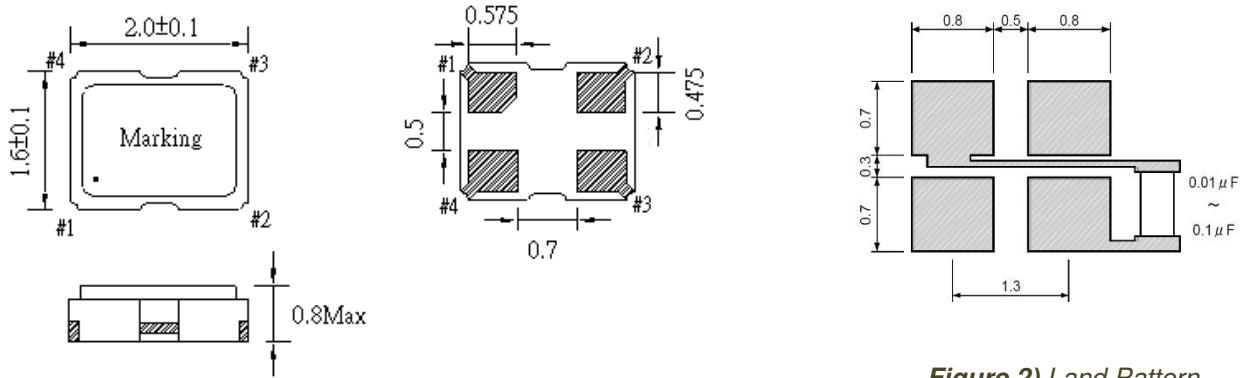

Figure 1) Top, Side, and Bottom views

Figure 2) Land Pattern

| Pin Connections | |
|-----------------|--------|
| #1 | Ground |
| #2 | Ground |
| #3 | Output |
| #4 | VDD |

| Developed Frequencies | |
|-----------------------|-----------------|
| * Abbreviation | Frequency (MHz) |
| 200 | 20.000 |
| 260 | 26.000 |
| 320 | 32.000 |
| 384 | 38.400 |
| 390 | 39.000 |
| 400 | 40.000 |

