

ITEM #	PART #	QTY	DESCRIPTION
1	MAJ-60-07	1	INSERT ASSY, RECEPTACLE
2	MAJ-60-05	1	NUT, (PM-MA)
3	MAJ-60-16	1	O-RING, PANEL MOUNT

B MAJ-60-00

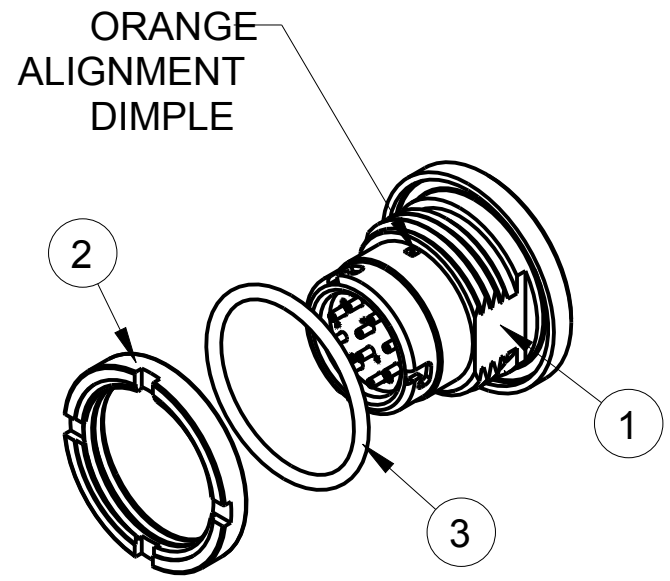
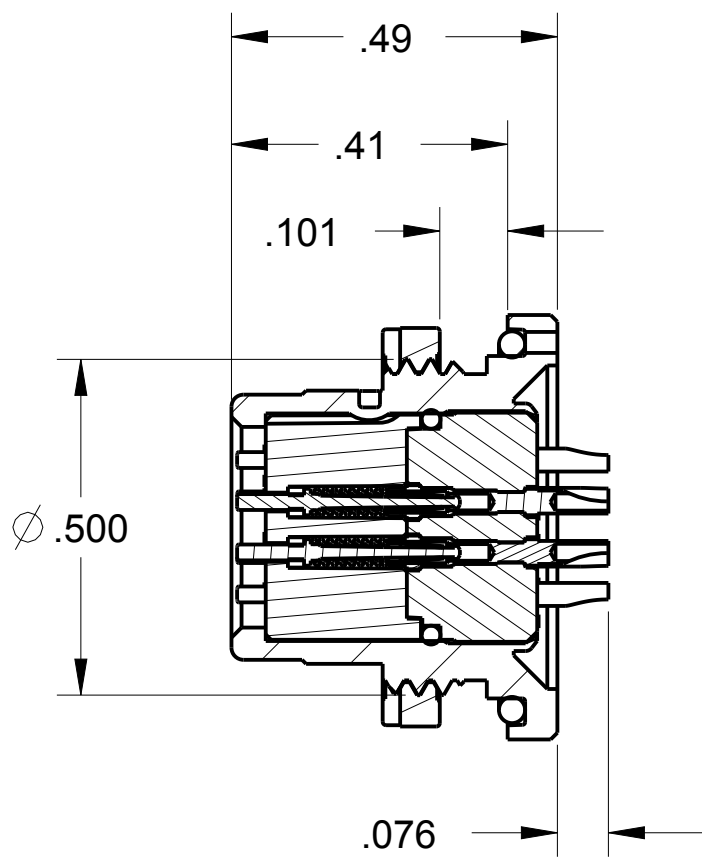
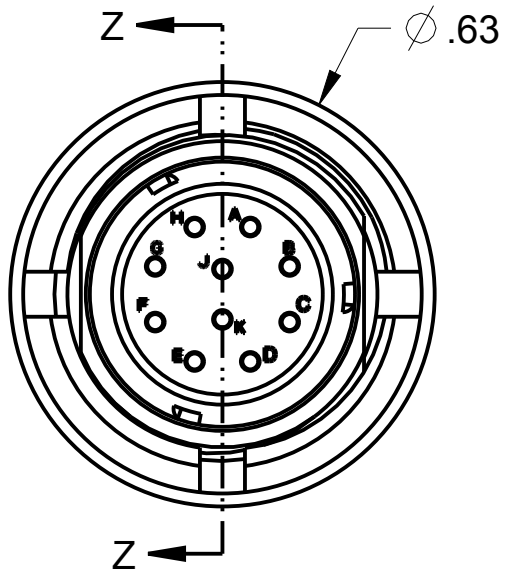
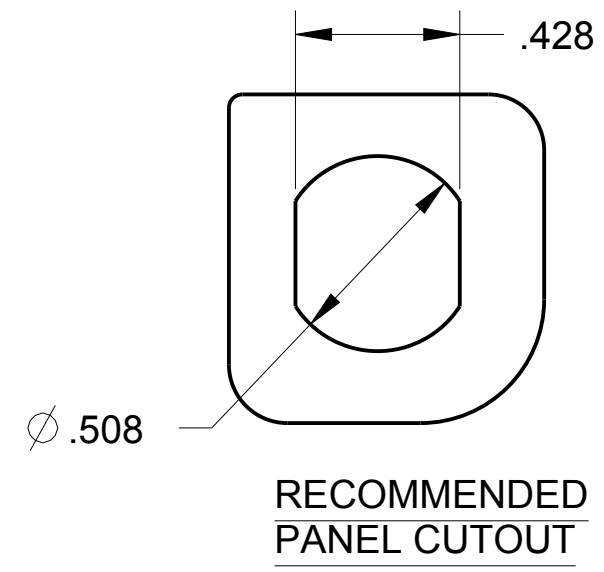

THIS DOCUMENT CONTAINS PROPRIETARY INFORMATION OF NEXUS, INCORPORATED AND SUCH INFORMATION MAY NOT BE DISCLOSED TO OTHERS FOR ANY PURPOSE OR USED FOR ANY PURPOSE WITHOUT THE WRITTEN CONSENT OF NEXUS.

LET.	REVISION	CN #	DATE	CHK.
A	NEW RELEASE		5/2 2012	HR

DWN.BY	HR	DATE	23-May-11
CHECKED BY		DATE	
APPR.BY		DATE	
UNLESS OTHERWISE SPECIFIED: DIMENSIONS ARE IN INCHES &/OR (mm)			
TOLERANCES:			
DECIMAL: .XX[X.X] .XXX[X.XX]		± .01[0.3] ± .003[0.08]	
FRACTION: X/X		ANGLES: X ± .5°	
1/64			

MATERIAL	
FINISH	
WEIGHT —	SCALE = 2.00 :1
TITLE	
10 COND RECEPTACLE PANEL MOUNT	
DO NOT SCALE DWG.	SHEET 1 OF 1

NEXUS STAMFORD, CONN	
B	MAJ-60-00