



mikromedia™

for dsPIC33EP®

Compact development system rich with on-board peripherals for all-round multimedia development on dsPIC33EP512MU810 device.



TO OUR VALUED CUSTOMERS

I want to express my thanks to you for being interested in our products and for having confidence in Mikroelektronika.

The primary aim of our company is to design and produce high quality electronic products and to constantly improve the performance thereof in order to better suit your needs.

A white handwritten signature in cursive script, appearing to read 'NM', set against a dark purple background.

Nebojsa Matic
General Manager

Table of Contents

Introduction to mikromedia for dsPIC33EP®	4	Programming with mikroProg™ programmer	16
Package Contains	5	mikroProg Suite™ for PIC® Software	17
Key Features	6	Programming with ICD2® or ICD3® programmer	18
System Specification	7	4. Reset Button	20
1. Power supply	8	5. Crystal Oscillator	22
USB power supply	8	6. MicroSD Card Slot	23
Battery power supply	8	7. Touch Screen	24
2. dsPIC33EP512MU810 microcontroller	10	8. Audio Module	26
Key microcontroller features	10	9. USB connection	28
3. Programming the microcontroller	11	10. Accelerometer	30
Programming with mikroBootloader	12	11. Flash Memory	31
step 1 - Connecting mikromedia	12	12. Pads	32
step 2 - Browsing for .HEX file	13	13. Pinout	33
step 3 - Selecting .HEX file	13	14. Dimensions	34
step 4 - Uploading .HEX file	14	15. mikromedia Accessories	35
step 5 - Finish upload	15	16. What's Next	36

Introduction to mikromedia for dsPIC33EP®

The **mikromedia for dsPIC33EP®** is a compact development system with lots of on-board peripherals which allow development of devices with multimedia contents. The central part of the system is a 16-bit **dsPIC33EP512MU810** microcontroller. The mikromedia for dsPIC33EP features integrated modules such as stereo MP3 codec, **TFT 320x240 touch screen** display, accelerometer, USB connector, audio connector, MMC/SDcard slot, 8Mbit flash memory, 2x26 connection pads and other. It comes pre-programmed with USB HID bootloader, but can also be programmed with external programmers, such as mikroProg™ or ICD2/3. Mikromedia is compact and slim, and perfectly fits in the palm of the hand, which makes it convenient platform for mobile devices.



Package Contains



- 01 Damage resistant protective box



- 02 mikromedia for dsPIC33EP® development system



- 03 DVD with documentation and examples



- 04 mikromedia for dsPIC33EP® user's guide



- 05 mikromedia for dsPIC33EP® schematic



- 06 USB cable

Key Features

- 01 Connection Pads
- 02 TFT 320x240 display
- 03 USB MINI-B connector
- 04 CHARGE indication LED
- 05 LI-Polymer battery connector
- 06 3.5mm headphone connector
- 07 Power supply regulator
- 08 Serial Flash memory
- 09 RESET button
- 10 VS1053 Stereo mp3 coder/decoder
- 11 dsPIC33EP512MU810 microcontroller
- 12 Accelerometer
- 13 Crystal oscillator
- 14 Power indication LED
- 15 microSD Card Slot
- 16 ICD2/3 connector
- 17 mikroProg connector

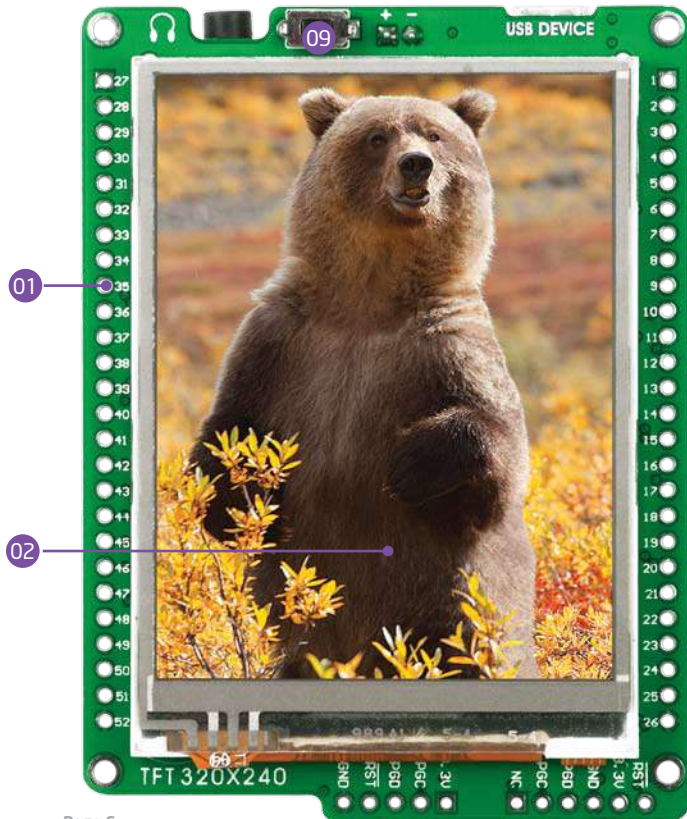

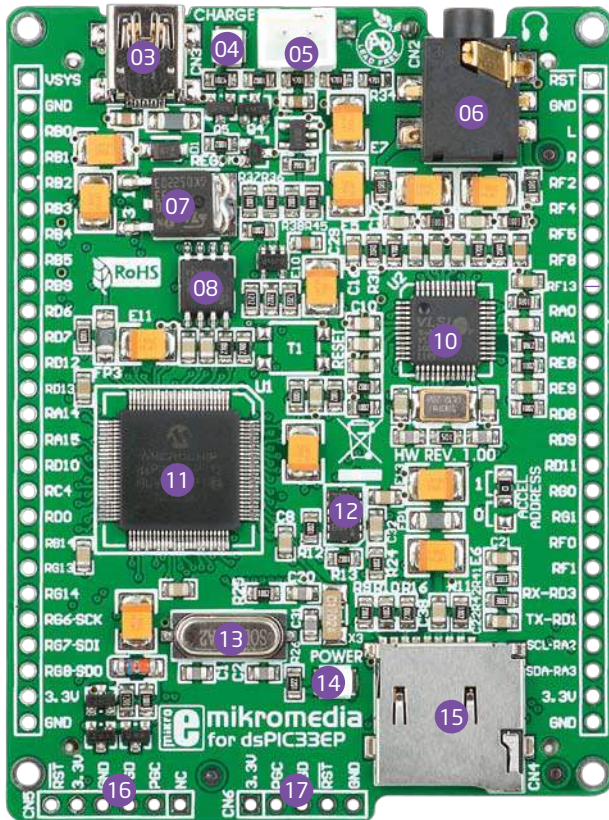

System Specification



power supply

Via USB cable (5V DC)



power consumption

75 mA with erased MCU
(when on-board modules are inactive)

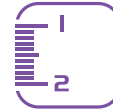

board dimensions

81.2 x 60.5mm (3.19 x 2.38 inch)



weight

~50 g (0.11 lbs)

1. Power supply

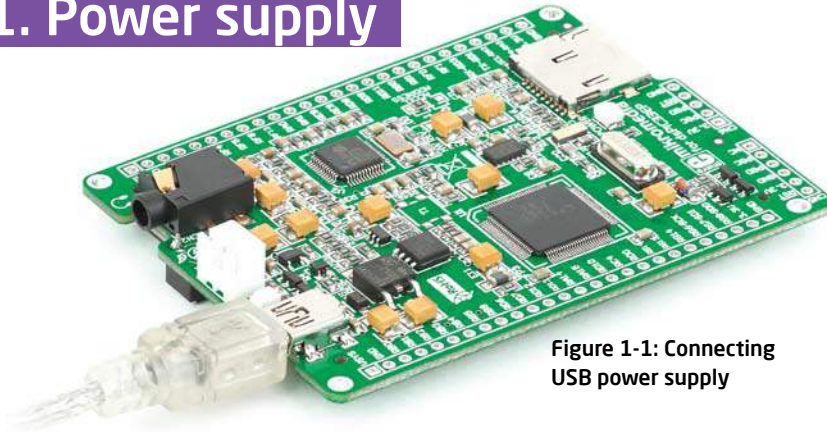

Figure 1-1: Connecting USB power supply

USB power supply

You can apply power supply to the board using **MINI-B USB** cable provided with the board. On-board voltage regulators provide the appropriate voltage levels to each component on the board. **Power LED (GREEN)** will indicate the presence of power supply.

Battery power supply

You can also power the board using **Li-Polymer** battery, via on-board battery connector. On-board battery charger circuit **MCP73832** enables you to charge the battery over USB connection. **LED diode (RED)** will indicate when battery is charging. Charging current is ~250mA and charging voltage is 4.2V DC.

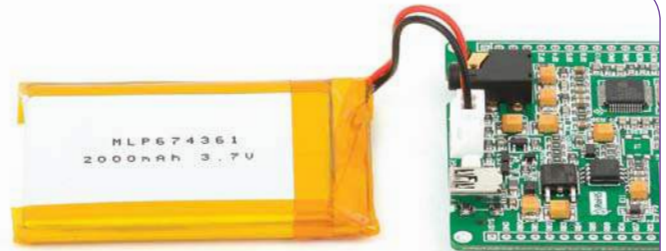

Figure 1-2: Connecting Li-Polymer battery

2. dsPIC33EP512MU810 microcontroller

The **mikromedia for dsPIC33EP®** development system comes with the **dsPIC33EP512MU810** microcontroller. This high-performance 16-bit microcontroller with its integrated modules and in combination with other on-board modules is ideal for multimedia applications.

Key microcontroller features

- Up to **70 MIPS** Operation;
- 16-bit architecture;
- 512KB of program memory, 24KB of auxiliary flash;
- 53.248 Bytes of RAM memory;
- 83 I/O pins;
- Internal Oscillator 7.37 MHz, 32kHz; RTCC
- nanoWatt features: Fast Wake/Fast Control;
- 4-UART, 4-SPI, 2-I2C, 2-CAN, USB 2.0 OTG;
- DAC, ADC, etc.

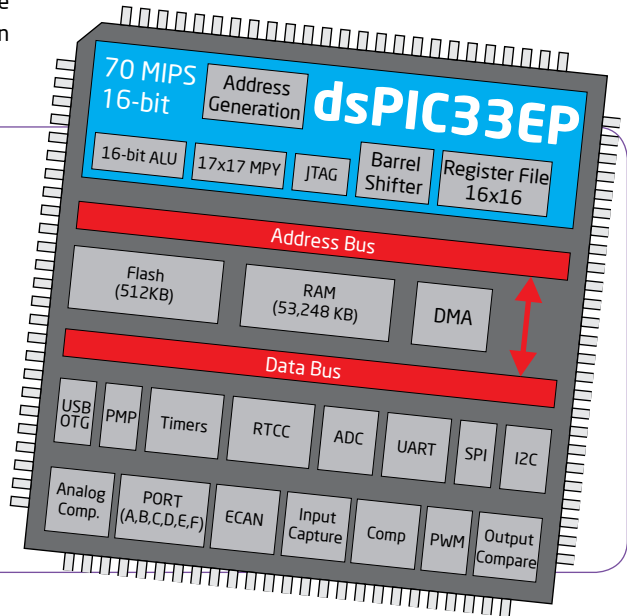

3. Programming the microcontroller

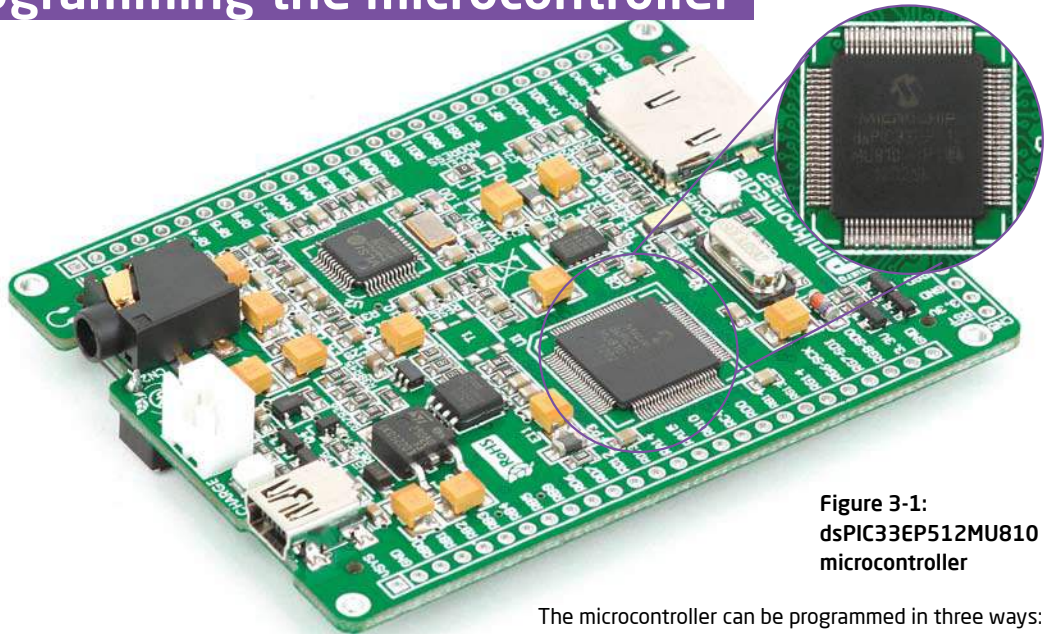

Figure 3-1:
dsPIC33EP512MU810
microcontroller

The microcontroller can be programmed in three ways:

- 01 Over USB HID mikroBootloader
- 02 Using mikroProg™ external programmer
- 03 Using ICD2/3 external programmer

Programming with mikroBootloader

You can program the microcontroller with bootloader which is pre-programmed into the device by default. To transfer .hex file from a PC to MCU you need bootloader software (**mikroBootloader USB HID**) which can be downloaded from:



http://www.mikroe.com/eng/downloads/get/1859/mikrobootloader_dsPIC33ep_usbhid_v200.zip

After software is downloaded unzip it to desired location and start mikroBootloader USB HID software.

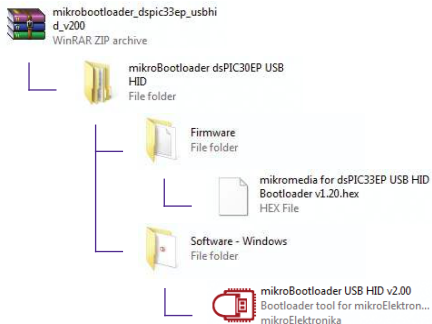

step 1 - Connecting mikromedia



Figure 3-2: USB HID mikroBootloader window

- 01 To start, connect the USB cable, or if already connected press the **Reset** button on your mikromedia board. Click the **"Connect"** button within 5s to enter the bootloader mode, otherwise existing microcontroller program will execute.

step 2 - Browsing for .HEX file



Figure 3-3: Browse for HEX

- 01 Click the **"Browse for HEX"** button and from a pop-up window (**Figure 3.4**) choose the .HEX file which will be uploaded to MCU memory.

step 3 - Selecting .HEX file



Figure 3-4: Selecting HEX

- 01 Select .HEX file using open dialog window.
- 02 Click the **"Open"** button.

step 4 - Uploading .HEX file



Figure 3-5: Begin uploading

- 01 To start .HEX file boot loading click the "Begin uploading" button.



Figure 3-6: Progress bar

- 01 You can monitor .HEX file uploading via progress bar

step 5 - Finish upload



Figure 3-7: Restarting MCU

- 01** Click the **"OK"** button after uploading is finished and wait for 5 seconds. Board will automatically reset and your new program will execute.



Figure 3-8: mikroBootloader ready for next job

Programming with mikroProg™

programmer

The microcontroller can be programmed with **mikroProg™ programmer** and **mikroProg Suite™ for PIC®** software. The mikroProg™ programmer is connected to the development system via the CN6 connector, **Figure 3-9**.



Figure 3-9:
Connecting mikroProg™ to mikroMedia™

mikroProg™ is a fast USB 2.0 programmer with mikroICD™ hardware In-Circuit Debugger. Smart engineering allows mikroProg™ to support PIC10®, PIC12®, PIC16®, PIC18®, dsPIC30/33®, PIC24® and PIC32® devices in a single programmer. It supports over 570 microcontrollers from Microchip®. Outstanding performance, easy operation and elegant design are its key features.

mikroProg Suite™ for PIC® Software



mikroProg™ programmer requires special programming software called **mikroProg Suite™ for PIC®**. This software is used for programming of ALL Microchip® microcontroller families, including PIC10®, PIC12®, PIC16®, PIC18®, dsPIC30/33®, PIC24® and PIC32®. Software has intuitive interface and SingleClick™ programming technology. Just by downloading the latest version of **mikroProg Suite™** your programmer is ready to program new devices. **mikroProg Suite™** is updated regularly, at least four times a year, so your programmer will be more and more powerful with each new release.

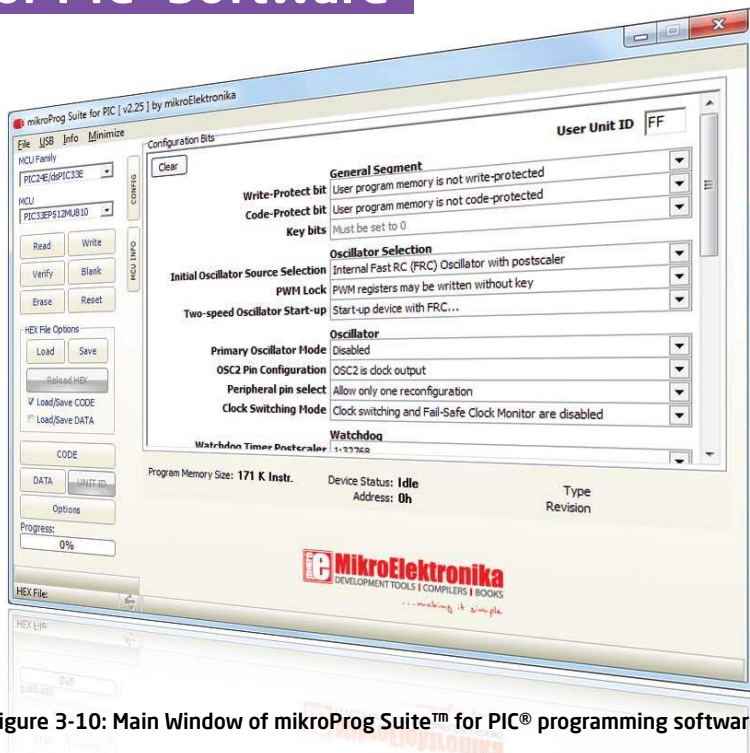

Figure 3-10: Main Window of mikroProg Suite™ for PIC® programming software

Programming with

ICD2® or ICD3® programmer

The microcontroller can be also programmed with **ICD2®** or **ICD3® programmer**. These programmers connects with mikromedia board via **ICD2 CONNECTOR BOARD**.

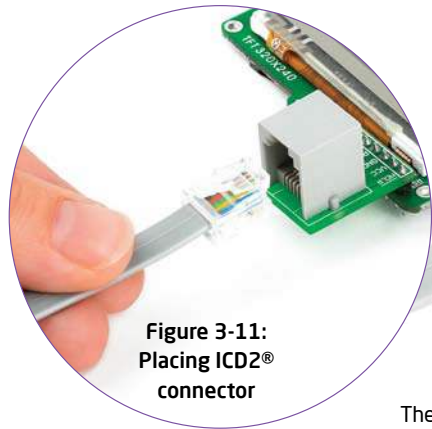

Figure 3-11:
Placing ICD2®
connector

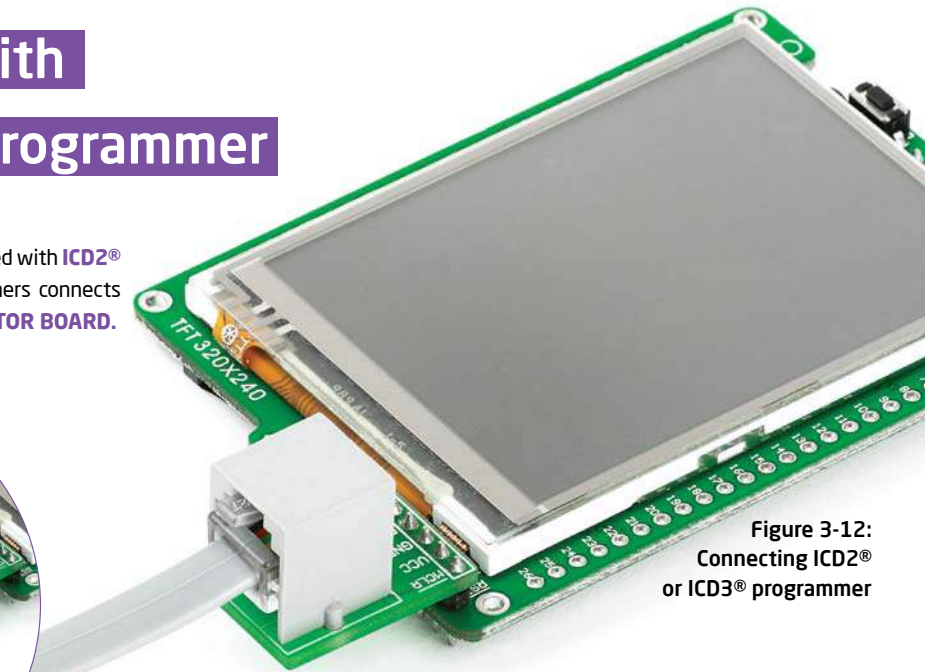
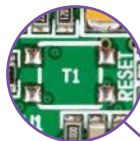

Figure 3-12:
Connecting ICD2®
or ICD3® programmer

In order to enable the ICD2® and ICD3® programmers to be connected to the mikromedia board, it is necessary to provide the appropriate connector such as the **ICD2 CONNECTOR BOARD**. This connector should be first soldered on the CN5 connector. Then you should plug the ICD2® or ICD3® programmer into it, **Figure 3-11**.

4. Reset Button

Board is equipped with reset button, which is located at the top of the front side (**Figure 4-2**). If you want to reset the circuit, press the reset button. It will generate low voltage level on microcontroller reset pin (input). In addition, a reset can be externally provided through **pin 27** on side headers (**Figure 4-3**).



NOTE

*You can also solder additional reset button on the appropriate place at the back side of the board, **Figure 4-1**.*

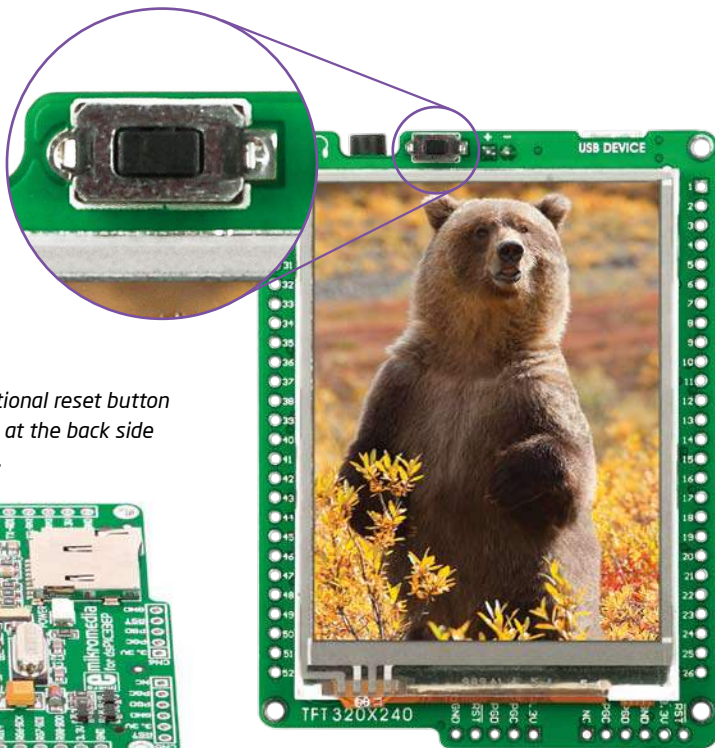
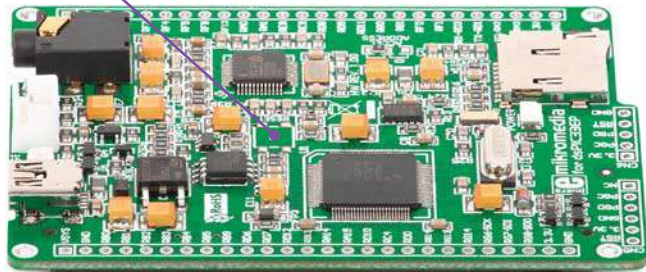

Figure 4-2: Frontal reset button

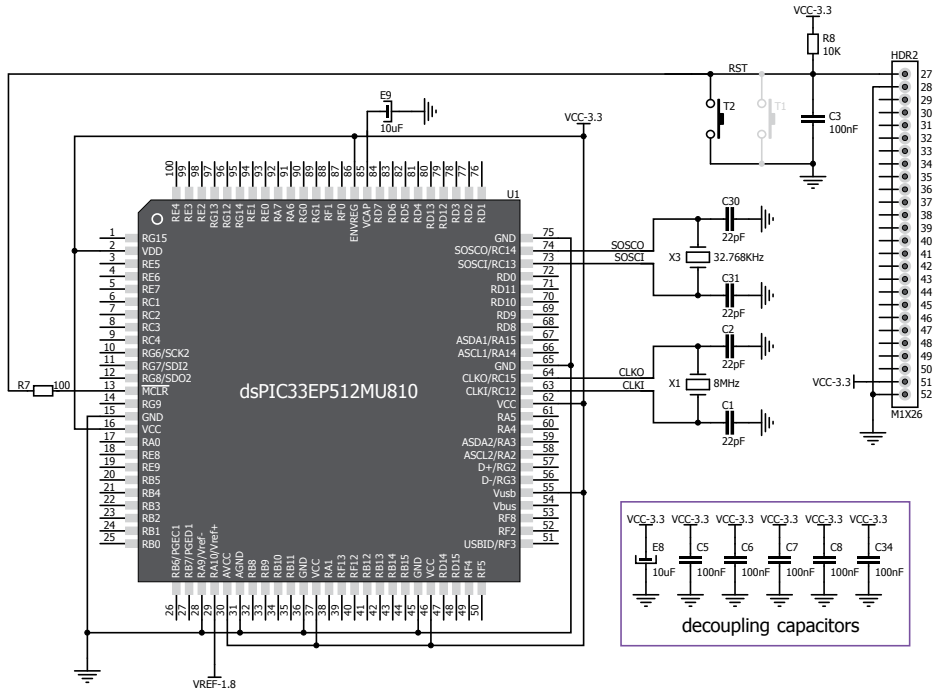

Figure 4-3: Reset circuit schematic

5. Crystal oscillator

Board is equipped with **8MHz crystal oscillator (X1)** circuit that provides external clock waveform to the microcontroller CLKO and CLKI pins. This base frequency is suitable for further clock multipliers and ideal for generation of necessary USB clock, which ensures proper operation of bootloader and your custom USB-based applications. Board also contains **32.768kHz Crystal oscillator (X3)** which provides external clock for internal **RTCC** module.

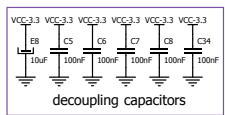
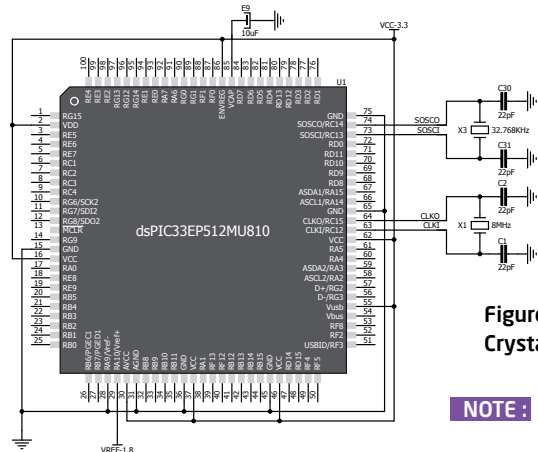

Figure 5-1:
External crystal oscillator (X1)



Figure 5-2:
Crystal oscillator schematic

NOTE: The use of crystal in all other schematics is implied even if it is purposely left out because of the schematics clarity.

7. Touch Screen

The development system features a **TFT 320x240 display** covered with a **resistive** touch panel. Together they form a functional unit called a **touch screen**. It enables data to be entered and displayed at the same time. The TFT display is capable of showing graphics in **262.144** different **colors**.

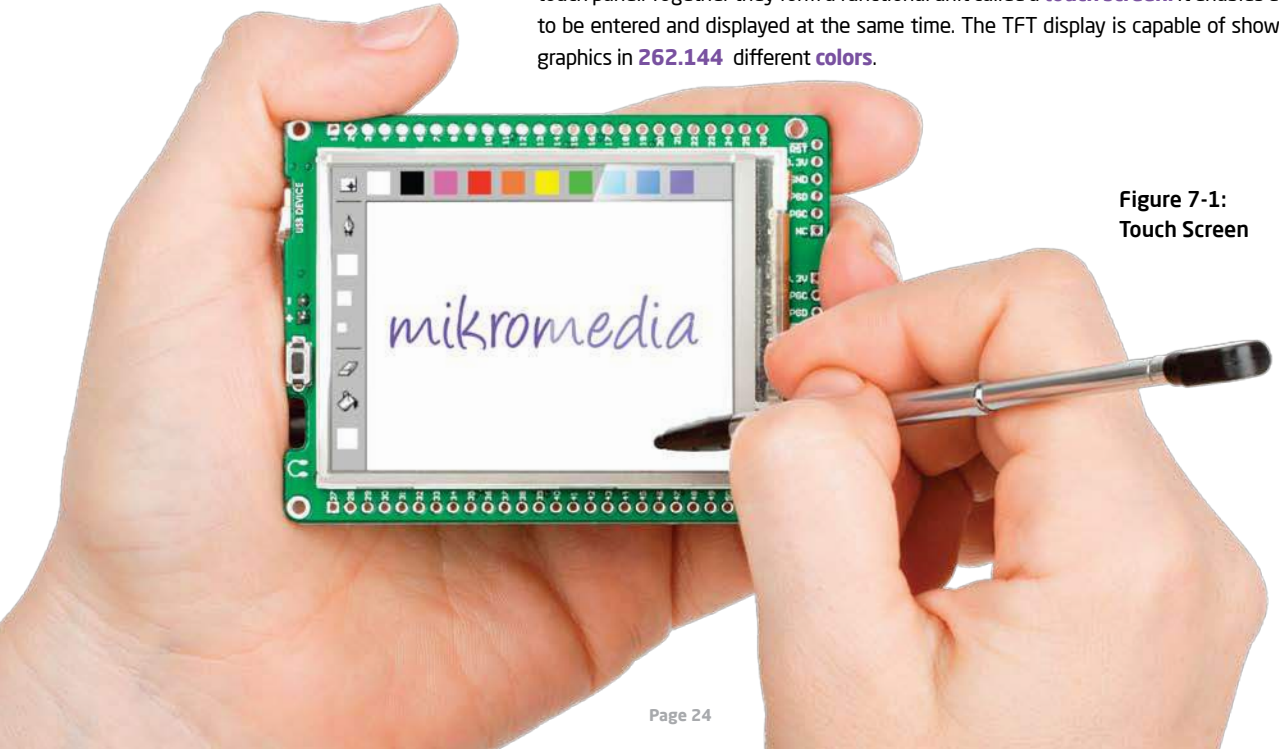

Figure 7-1:
Touch Screen

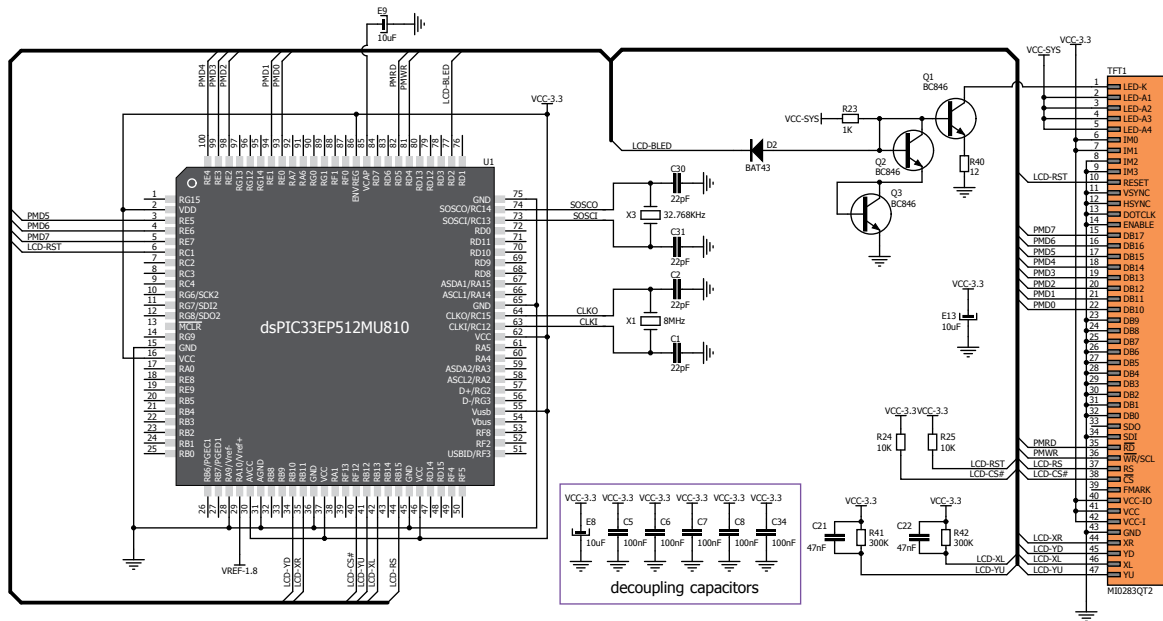

Figure 7-2: Touch Screen connection schematic

8. Audio Module

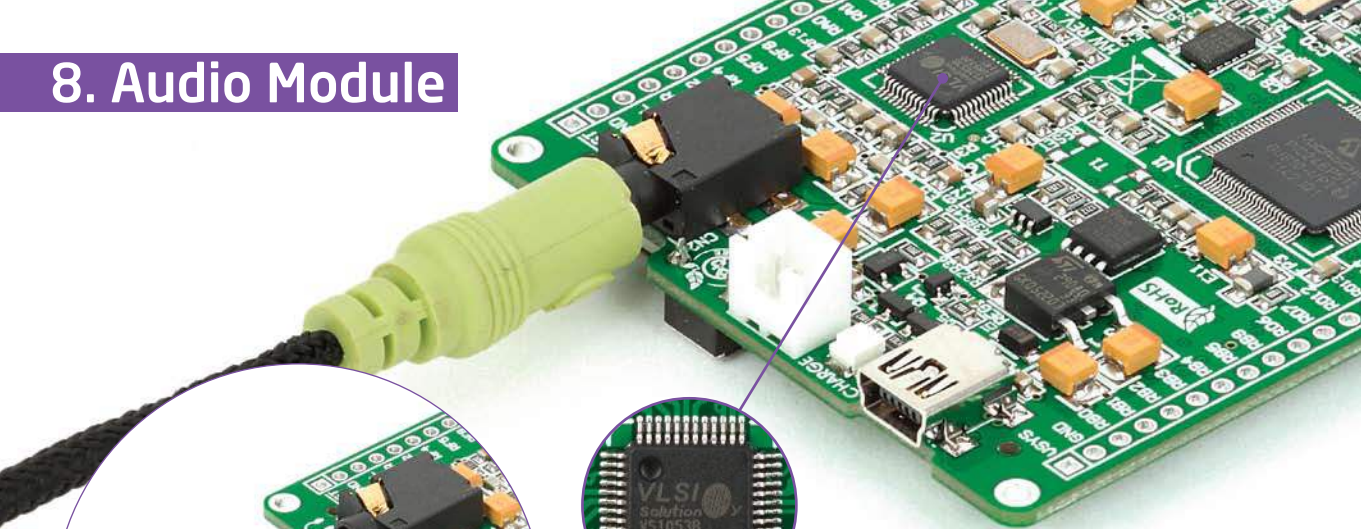

Figure 8-2:
Inserting 3.5mm
headphones jack



Figure 8-1:
On-board VS1053
MP3 codec

The mikromedia for dsPIC33EP® features stereo audio codec **VS1053**. This module enables audio reproduction by using stereo headphones connected to the system via a **3.5mm** connector CN2. All functions of this module are controlled by the microcontroller over Serial Peripheral Interface (**SPI**).

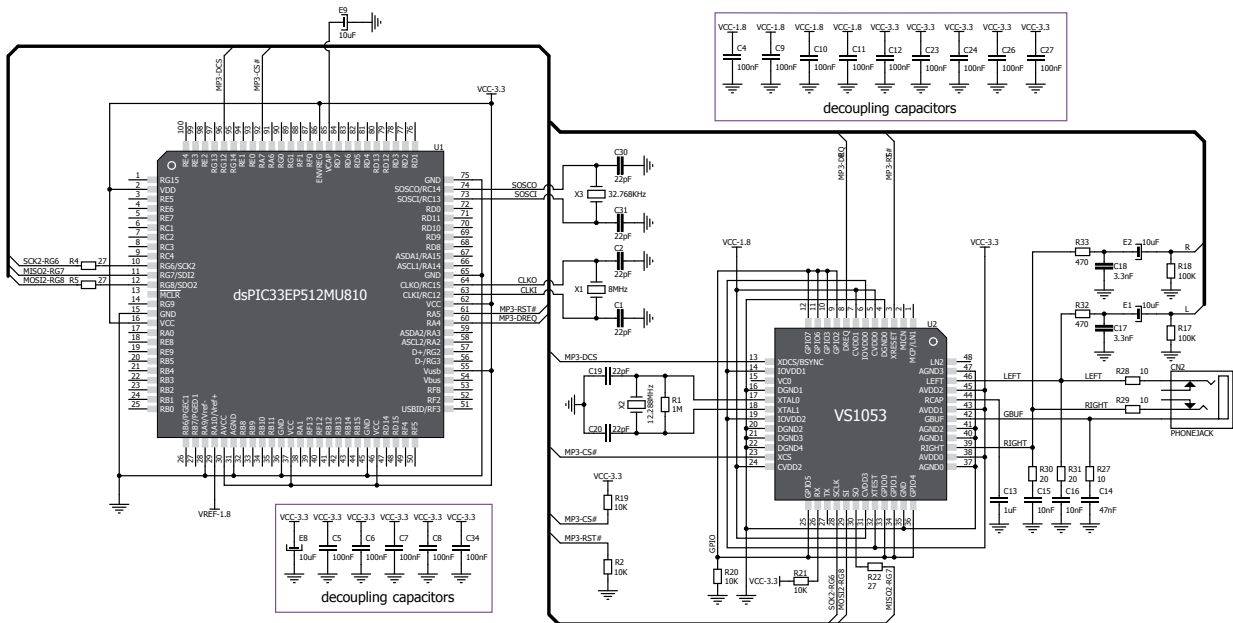
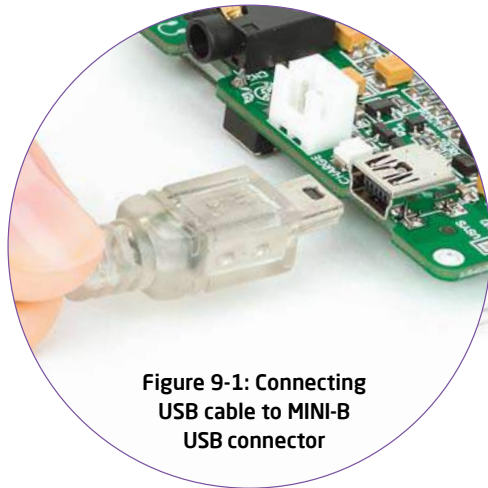

Figure 8-3: Audio module connection schematic

9. USB connection

dsPIC33EP512MU810 microcontroller has integrated USB module, which enables you to implement USB communication functionality to your mikromedia board. Connection with target USB host is done over MINI-B USB connector which is positioned next to the battery connector.



**Figure 9-1: Connecting
USB cable to MINI-B
USB connector**

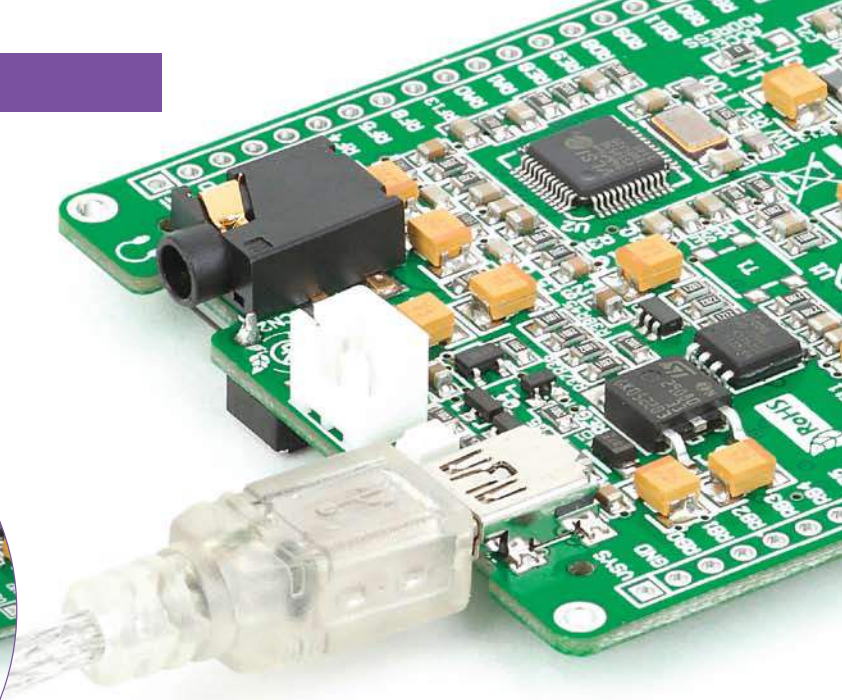

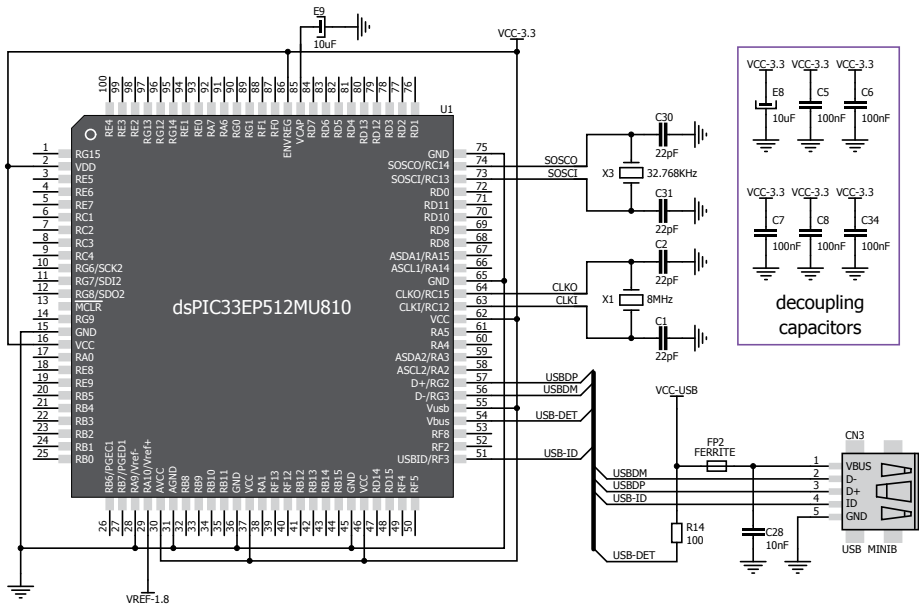

Figure 9-2: USB module connection schematic

10. Accelerometer

On board **ADXL345** accelerometer is used to measure acceleration in three axis: x, y and z. The accelerometer's function is defined by the user in the program loaded into the microcontroller. Communication between the accelerometer and the microcontroller is performed via the **I²C** interface.

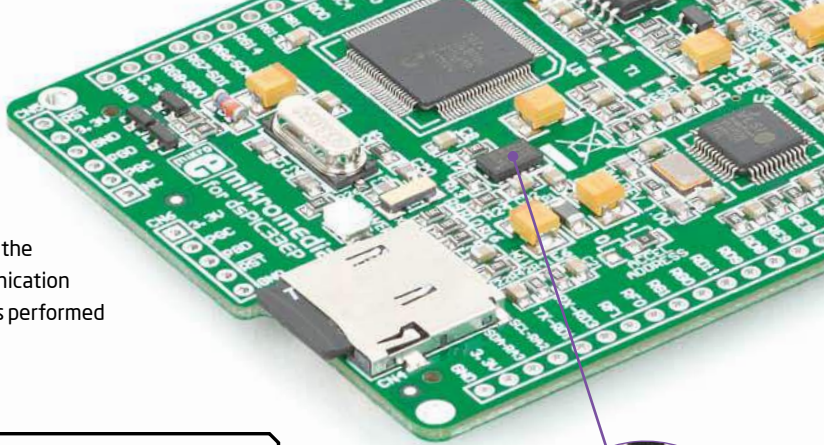

Figure 10-1:
Accelerometer module

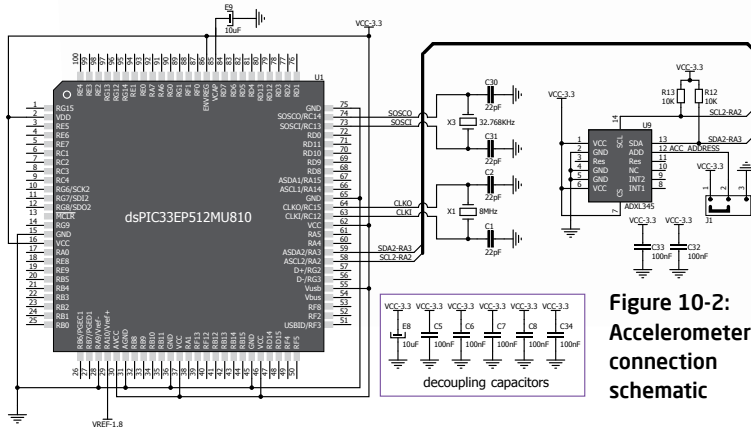
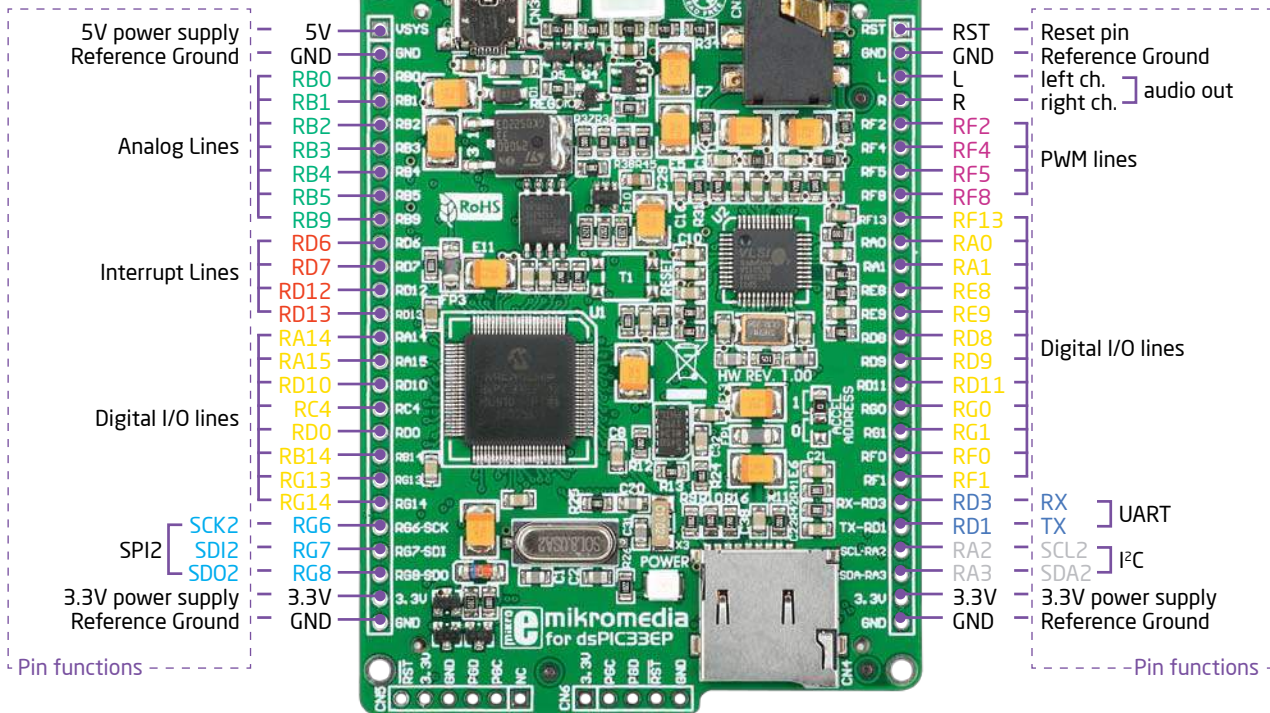

Figure 10-2:
Accelerometer connection schematic



You can set the accelerometer address to 0 or 1 by re-soldering the SMD jumper (zero-ohm resistor) to the appropriate position. Jumper is placed in address 1 position by default.

13. Pinout



■ Digital lines
 ■ Analog Lines
 ■ Interrupt Lines
 ■ SPI Lines
 ■ I2C Lines
 ■ UART lines
 ■ PWM lines

14. Dimensions

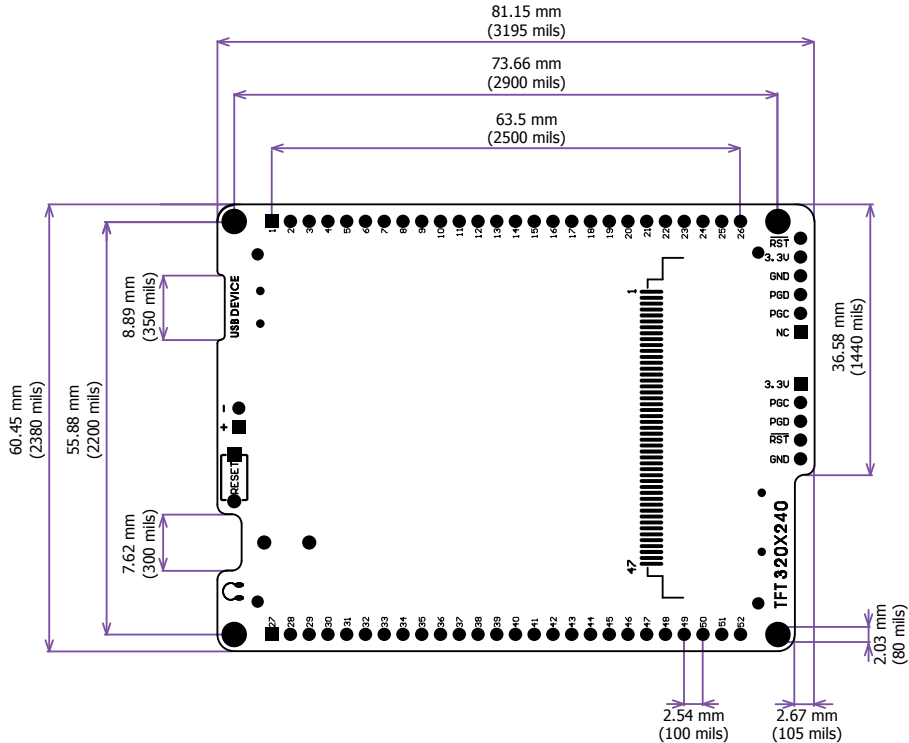

15. mikromedia accessories

We have prepared a set of extension boards pin-compatible with your mikromedia, which enable you to easily expand your board basic functionality. We call them mikromedia shields. But we also offer other accessories, such as Li-polymer battery, stacking headers, wire jumpers and more.



01 Connect shield



02 BatteryBoost shield



03 PROTO shield

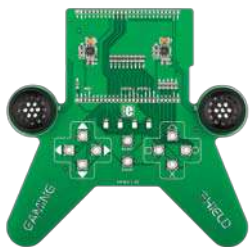

04 Gaming shield



05 mikroBUS shield



06 Li-Polymer battery



07 Wire Jumpers

What's next?

You have now completed the journey through each and every feature of mikromedia for dsPIC33EP board. You got to know its modules and organization. Now you are ready to start using your new board. We are suggesting several steps which are probably the best way to begin. We invite you to join the users of mikromedia™ brand. You will find very useful projects and tutorials and can get help from a large ecosystem of users. Welcome!

Compiler

You still don't have an appropriate compiler? Locate dsPIC® compiler that suits you best on the Product DVD provided with the package:

DVD://download/eng/software/compilers/

Choose between mikroC™, mikroBasic™ and mikroPascal™ and download fully functional demo version, so you can begin building your first applications.



Projects

Once you have chosen your compiler, and since you already got the board, you are ready to start writing your first projects. **Visual TFT software** for rapid development of graphical user interfaces enables you to quickly create your GUI. It will automatically create necessary code which is compatible with mikroElektronika compilers. Visual TFT is rich with examples, which are an excellent starting point for your future projects. Just load the example, read well commented code, and see how it works on hardware. Visual TFT is also available on the Product DVD.

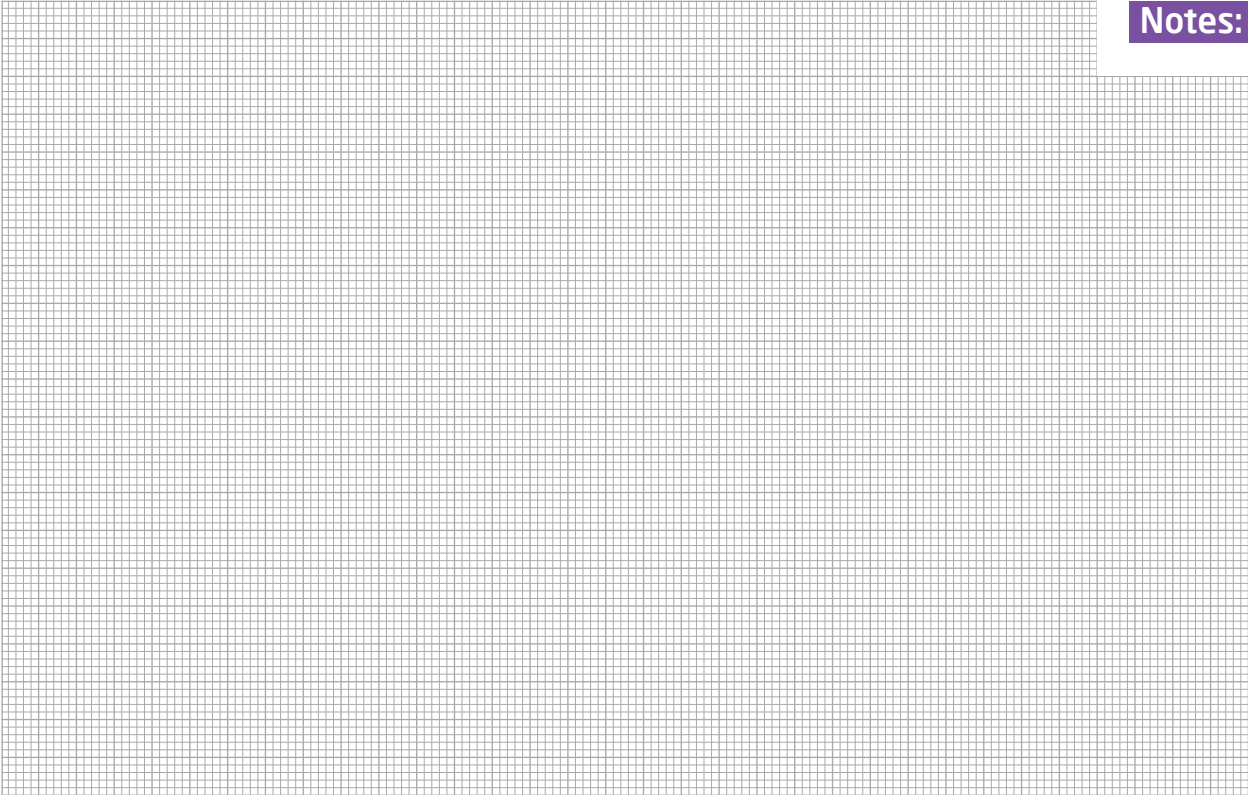

Notes:

DISCLAIMER

All the products owned by MikroElektronika are protected by copyright law and international copyright treaty. Therefore, this manual is to be treated as any other copyright material. No part of this manual, including product and software described herein, may be reproduced, stored in a retrieval system, translated or transmitted in any form or by any means, without the prior written permission of MikroElektronika. The manual PDF edition can be printed for private or local use, but not for distribution. Any modification of this manual is prohibited.

MikroElektronika provides this manual 'as is' without warranty of any kind, either expressed or implied, including, but not limited to, the implied warranties or conditions of merchantability or fitness for a particular purpose.

MikroElektronika shall assume no responsibility or liability for any errors, omissions and inaccuracies that may appear in this manual. In no event shall MikroElektronika, its directors, officers, employees or distributors be liable for any indirect, specific, incidental or consequential damages (including damages for loss of business profits and business information, business interruption or any other pecuniary loss) arising out of the use of this manual or product, even if MikroElektronika has been advised of the possibility of such damages. MikroElektronika reserves the right to change information contained in this manual at any time without prior notice, if necessary.

HIGH RISK ACTIVITIES

The products of MikroElektronika are not fault - tolerant nor designed, manufactured or intended for use or resale as on - line control equipment in hazardous environments requiring fail - safe performance, such as in the operation of nuclear facilities, aircraft navigation or communication systems, air traffic control, direct life support machines or weapons systems in which the failure of Software could lead directly to death, personal injury or severe physical or environmental damage ('High Risk Activities'). MikroElektronika and its suppliers specifically disclaim any expressed or implied warranty of fitness for High Risk Activities.

TRADEMARKS

The MikroElektronika name and logo, the MikroElektronika logo, mikroC™, mikroBasic™, mikroPascal™, mikroProg™, EasyPIC Fusion™, mikroBUS™, Click Boards™, mikroProg™, and mikromedia™ are trademarks of MikroElektronika. All other trademarks mentioned herein are property of their respective companies.

All other product and corporate names appearing in this manual may or may not be registered trademarks or copyrights of their respective companies, and are only used for identification or explanation and to the owners' benefit, with no intent to infringe.



If you want to learn more about our products, please visit our web site at www.mikroe.com

If you are experiencing some problems with any of our products or just need additional information, please place your ticket at www.mikroe.com/esupport

If you have any questions, comments or business proposals,
do not hesitate to contact us at office@mikroe.com

mikromedia for dsPIC33EP Manual
ver. 1.00



0 100000 020432