

**ECONOSEAL J MARK II<sup>+</sup> CONNECTOR  
(EJ-MK II<sup>+</sup>)****Customer Manual**

**NOTE:** This instruction manual may be changed without notices.

CONTENTS

Item No	Description	Page
1.	Harness Assembly Operation: . . . . .	1
1.1	Insertion of Crimped Contacts into Housing: .	1
1.2	Insertion of Cavity Plug into Housing: . . .	1
1.3	Assembly of Double Lock Plate: . . . . .	2
1.4	Correct Direction to Apply Double Lock Plate:	4
1.5	Removal of Double Lock Plate: . . . . .	5
1.6	Extraction of Contacts: . . . . .	6
2.	Repair and Maintenance: . . . . .	8

1. Harness Assembly Operation

1.1 Insertion of Crimped Contacts into Housing:

Before to insert contacts into housing, be sure to confirm their correct placing in housing cavities. Seeing the cross-sectional view of connectors, make sure with which side up, the contacts should be inserted into housing. Keeping correct direction for placing contacts is very important.

After insertion of a contact, pull back the crimped wire lightly to see if the contact is securely locked in position.

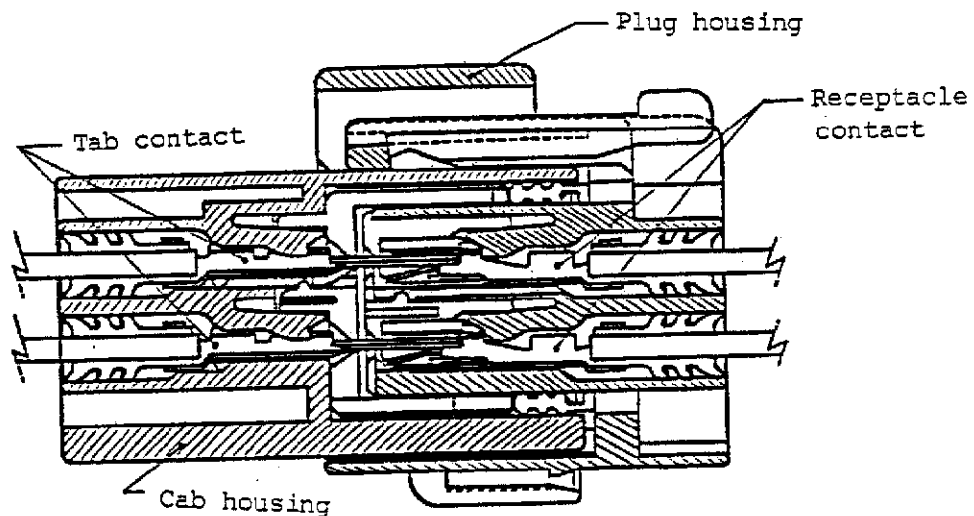
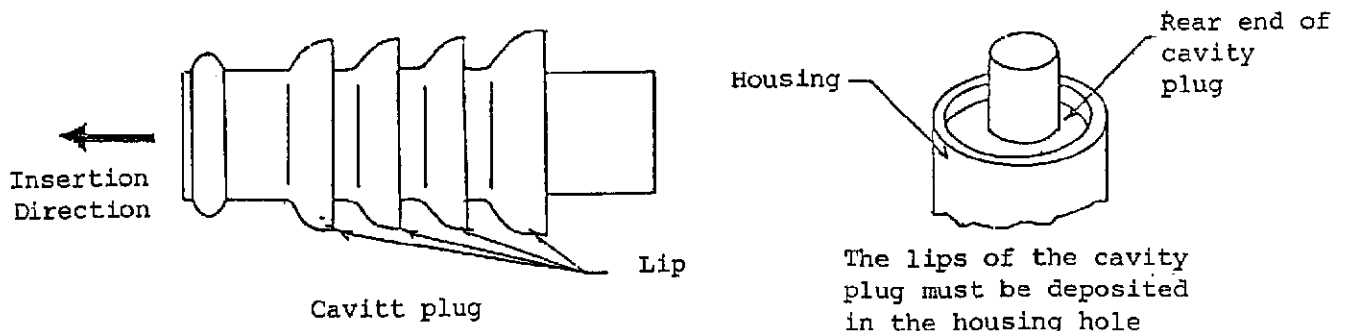

Fig. 1 Cross-sectional view of Mated Connectors

1.2 Insertion Work of Cavity Plug in Housing



Cavity plug is used for filling unloaded contact cavities to prevent water from entering the cavity holes. When to insert cavity plugs, be sure to insert with the round-flanged end first as shown above. After insertion of cavity plug, confirm that all the lips entered and are sinking fully in the hole. Refer to the sketch shown above

### 1.3 Assembly of Double Lock Plate:

A double lock plate is used to assure firm locking of connectors when mated. Insertion of double lock plate makes a complete locking of connectors, in addition to the conventional locking device of connectors.

Two types of double locking plates are available, i.e. one is for use on plug housing, and the other is for cap housing.

See figures below. They should be inserted properly, with correct placing in cavities as shown. Carefully insert them by hand. (Fig. 2)

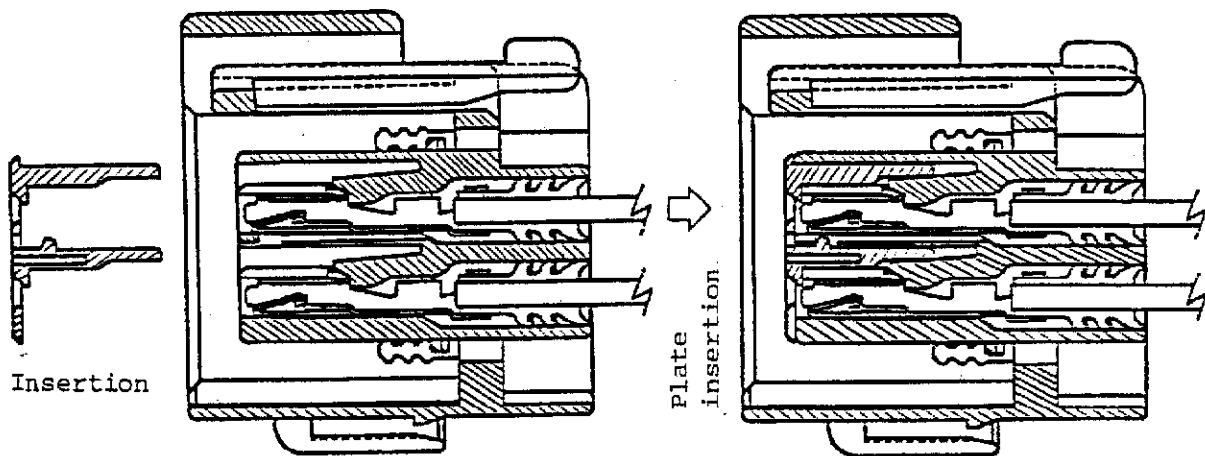

Fig. 2 Insertion of Plug Plate

For inserting locking plate for cap housing, an insertion jig should be used to keep correct placing.

To insert, first, put locking plate into housing entry, and then, push it with the use of jig as shown. For detailed instruction, refer to IS-377J, instruction sheet attached to the product. (Fig. 3 & Fig. 4)

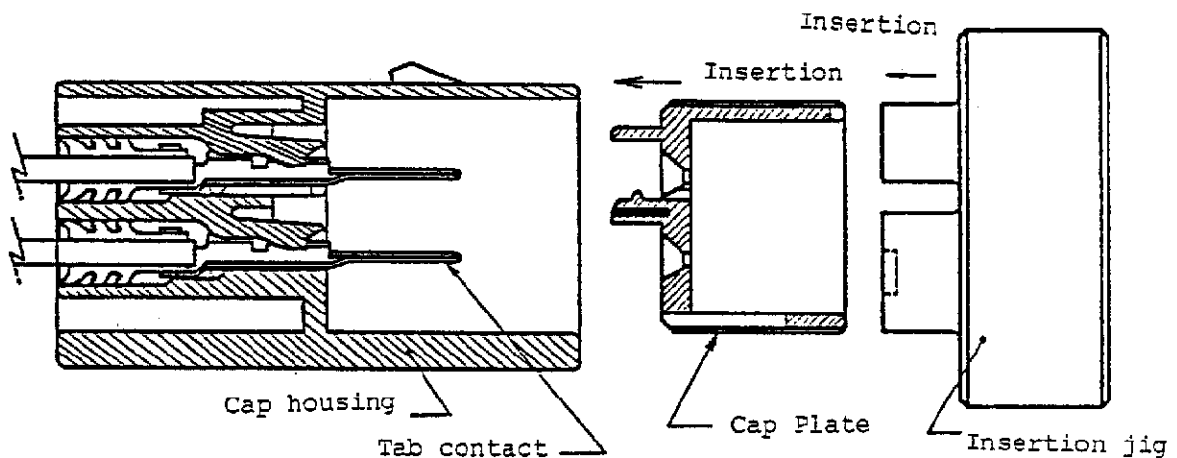

Fig. 3 Insertion of Cap Plate

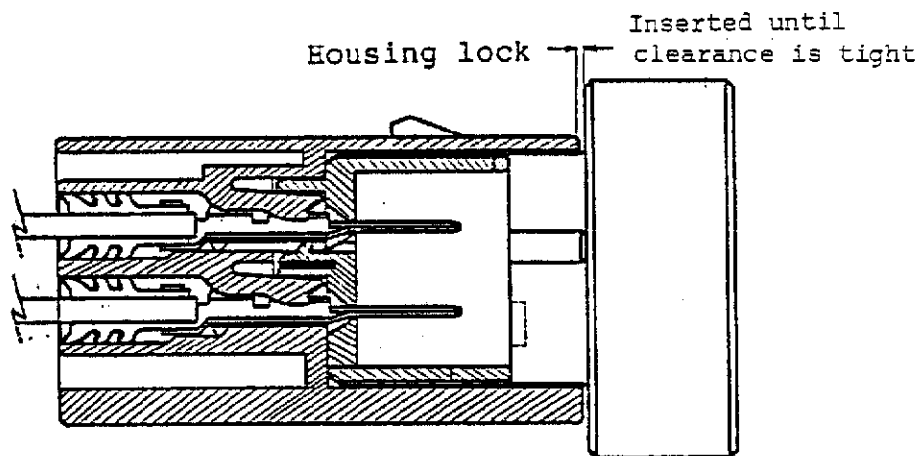

Fig. 4 Insertion Posture of Cap Plate

\* In order to insert plates for the plug housing and cap housing, if insertion cannot be done by pushing slightly the plate, pull back the plate first, avoiding forcing for insertion, and confirm two points as follows;

- (1) To see if the inserting direction is correct (See figure.)
- (2) If the contact is inserted fully and completely to the normal position? (In the condition that the plate is half-inserted, plate insertion cannot be done.)

Thus, after correcting these problems, insert the plate carefully again.

1.4 Correct Direction to Apply Double Lock Plate:

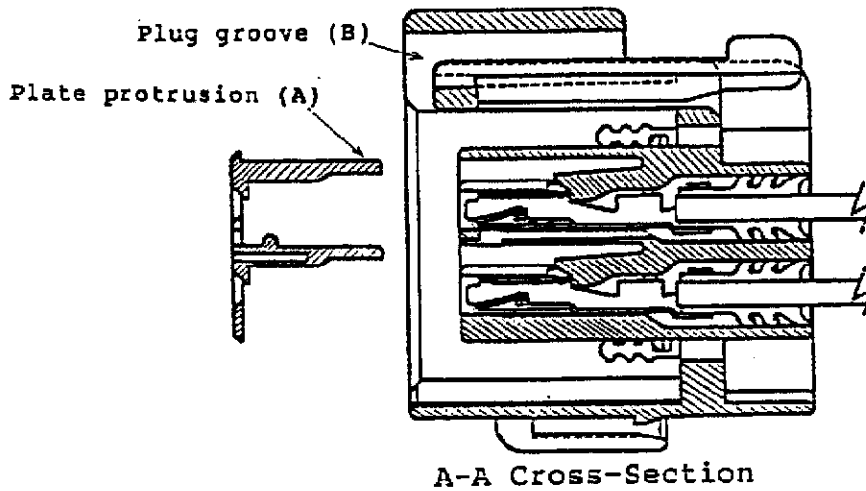

Fig. 5 Application of Double Lock Plate for Plug Housing:

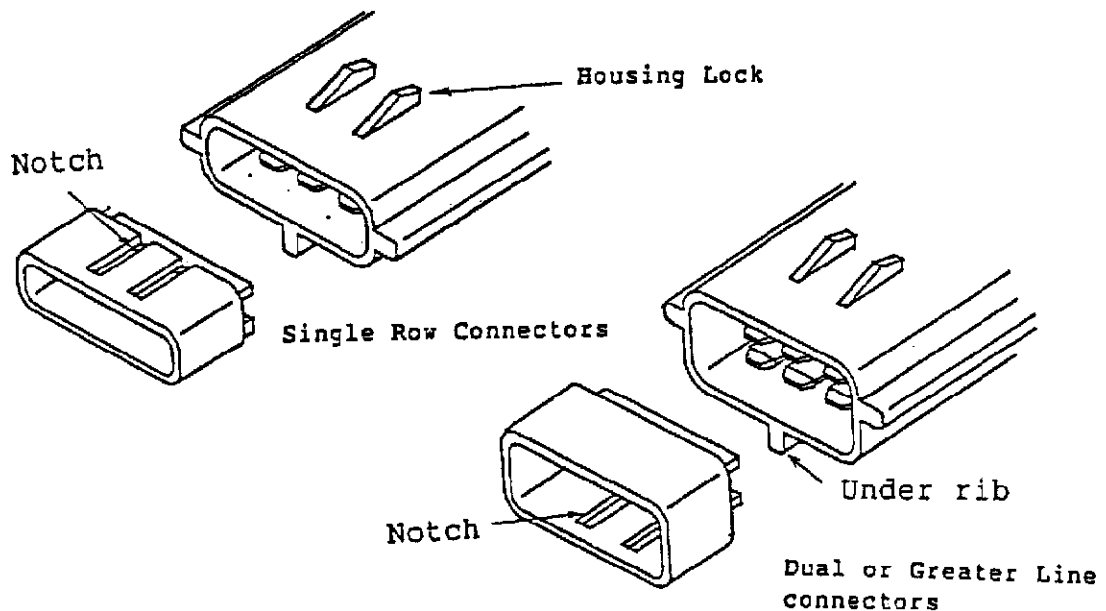

Fig. 6 Directivity of Cap Housing Plate

The plug housing should be inserted so that the plate protrusion (A) is inserted in the groove (B) of the housing as shown in Fig. 5. The cap housing should be inserted so that for single row connectors (i.e. 1, 2 & 3-pos.) the notch of the double lock plate can come to the housing lock side, and for connector of more than 2 lines (4, 6, 8, 10, 12 poles etc.) the notch of the double lock plate comes to the under lib side, as shown in Fig. 6.

1.5 Removal of Double Lock Plate

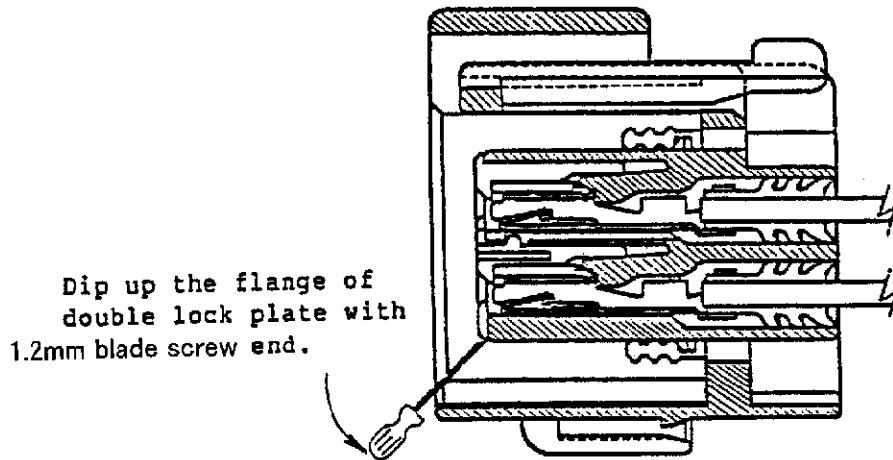

Fig. 7 Removal of Plate

When the plate must be removed owing to mis-wiring etc., Dig up the flange of double lock plate with the use of a screw-driver end, and remove from housing by hand, as shown in Fig. 7.

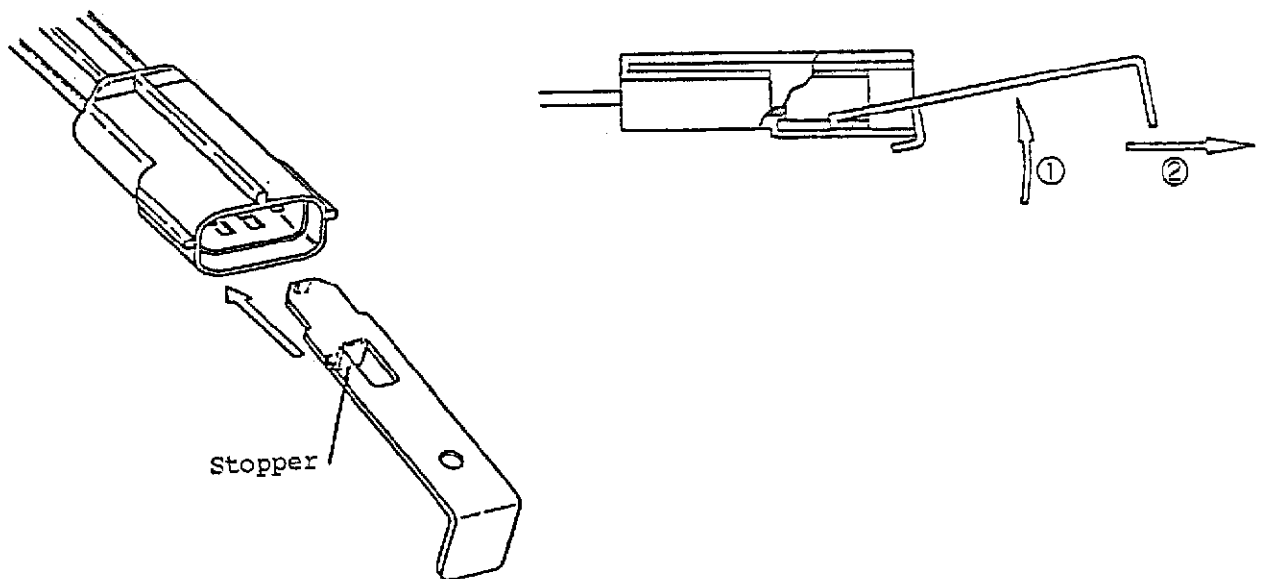

Fig. 8 Removal of Plate by Using Removal Jig.

- a When to remove plate from housing, use removal jig. First, insert the jig in the connector entry along the groove in the direction shown in Fig. 8, until it stops at the end, and remove it by pulling IS-375J, instruction sheet, attached to the product.

\* Cautions

- (1) Do not reuse the double lock plate, after it is once removed.
- (2) In the situation where the plate is mounted, the contact cannot be inserted and extracted.
- (3) In extraction of the plate, be careful so as not to deform the tab and damage the housing surface.

1.6 Extraction of Contact

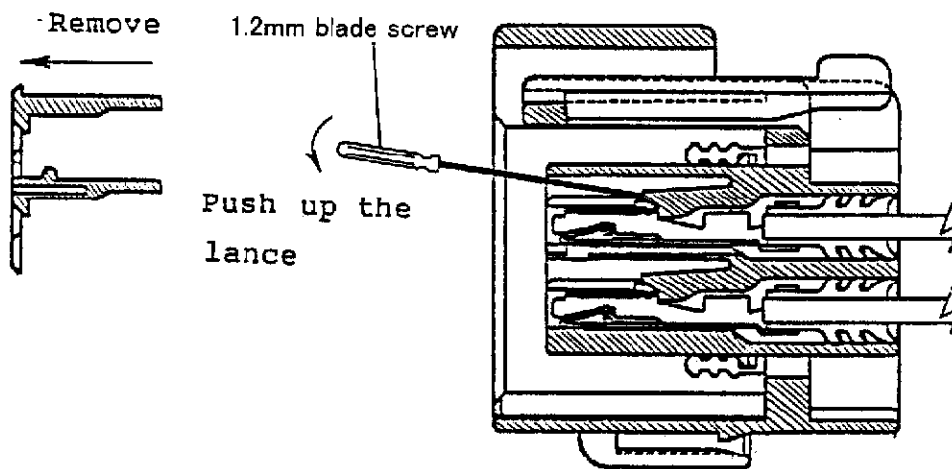

Fig. 9 Extraction of Receptacle Contact



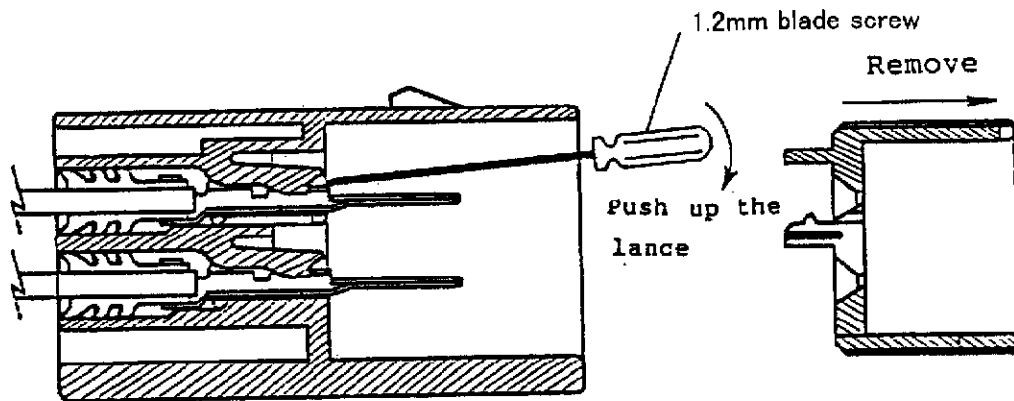
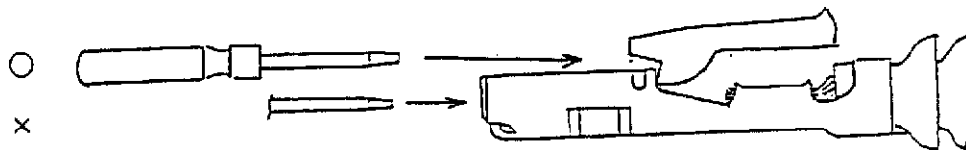

Fig. 10 Extraction of Tab contact

As Shown in Figs. 9 and 10, after the plate is removed, the lance is pushed up and extracted by means of a screwdriver.

\* Cautions

- \* Be careful not to insert the jig in the contacting area of the receptacle.



- \* At extraction of the jig, be careful not to deform the tab.

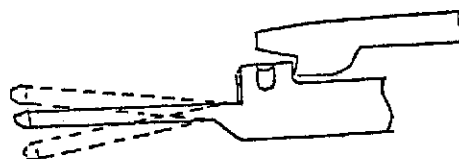

2. Repair and Maintenance.

During repair and maintenance operation of wiring system, replacement and reloading of contacts may occur. In such cases, the following procedure is recommended to be observed.

Proceed as follows:

- (1) Cut off the wire of defective contact which you are to remove from housing.
- (2) Strip the wire insulation to the length of 4 ~ 4.5 mm.
- (3) Slide the new rubber plug over the wire, before starting crimping.

The rubber plug insertion jig is prepared with such kinds as shown in Fig. 11.

	Easy Inserting Jig			Insertion Jig	
	For .070 series (0.2~0.5mm <sup>2</sup> Applicable)	For .070 series (0.5~1.25mm <sup>2</sup> Applicable)	.250 series	.070 series	.250 series
Jig No.	753838-1	753838-3	753838-2	753812-2	753812-1
Illustration					

Fig. 11

(3)-1 Use Method of Easy Inserting Jig

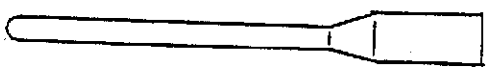
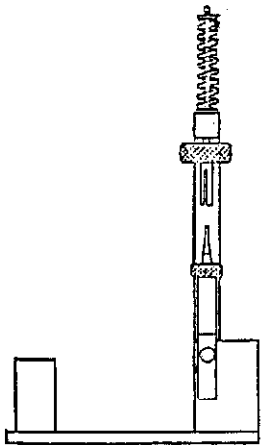
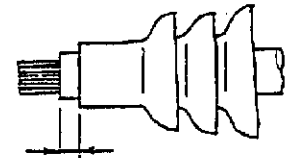
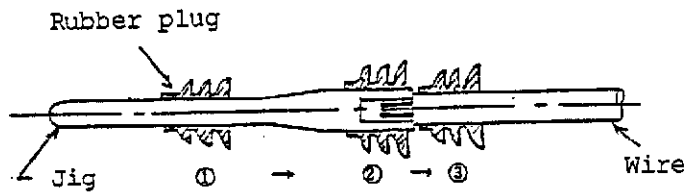

Protrusion length  
of wire: 0 ~ 1 mm

Apply rubber plug to  
the loading jig, in  
the sequence from 1  
to 3 by hand.

Do not allow the rubber  
flanges to be tilting,  
after applying it over  
the wire.

(3)-2 Use Method of Insertion Jig

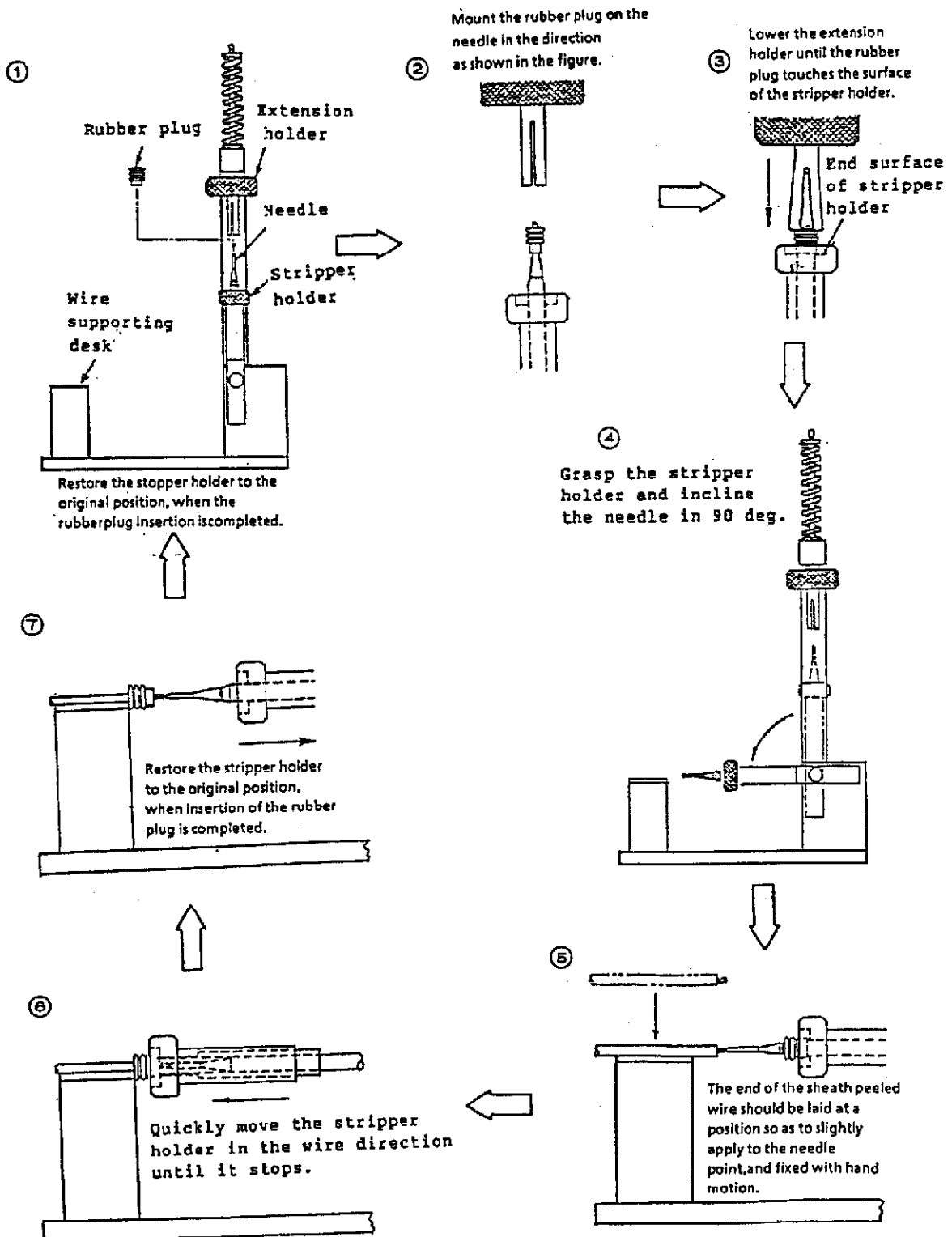

(4) Crimping

The wire insulation can be visually inspected as is crimped, or can see inside of rubber plug.

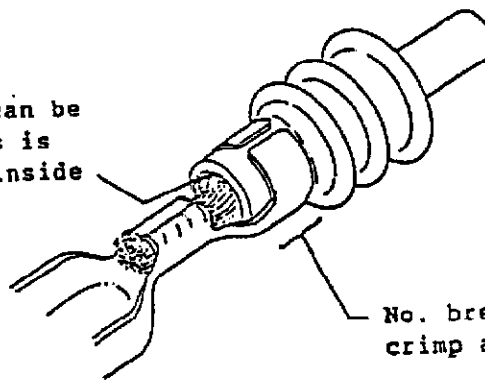

No. breakage nor damage due to crimp action, is allowed.

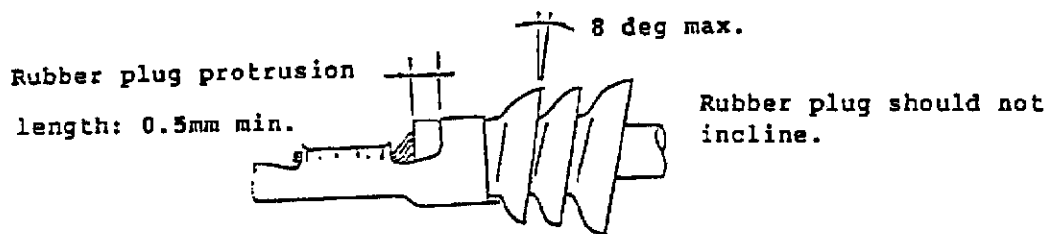

When the contact is deformed owing to crimping, it must be used after correction. In regard to specified details for deformation weight, refer to Specification for Mounting Practice No. 114-5082.

(Example) Bend up (upward) : 1 deg. max.

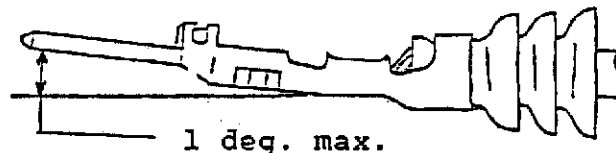

Bend down (downward): 3°max.

(5) Automatic Machine

The SCAT (Sealed Contact Automatic Terminator) is provided for wire sheath peeling, rubber plug mounting, contact crimping for .070 contact. In regard to the SCAT, refer to operation manual No. CM-234J.