



## Low-Noise Bottom Port Piezoelectric MEMS Microphone

Data Sheet

PMM-3738-VM1000-R

PUI Audio, featuring Vesper's exclusive technology, presents the world's first and only piezoelectric MEMS microphone. The PMM-3738-VM1000-R provides superior performance and quality in all environments.

### Features:

- Unique piezoelectric MEMS transducer
- Very-low noise floor
- Low part-to-part variation
- High dynamic range
- Stable performance in all conditions
- Dust and water resistant to IP57



The PMM-3738-VM1000-R is a low noise, low part-to-part variation, high dynamic range, single ended analog output piezoelectric MEMS microphone. This microphone consists of a piezoelectric sensor and circuitry to buffer and amplify the output.

The PMM-3738-VM1000-R has a small 3.76 mm X 2.95 mm X 1.1 mm package. This microphone is reflow solder compatible without sensitivity degradation.



## Specifications

All specifications are at 25°C,  $V_{Supply} = 1.8\text{ V}$  unless otherwise noted.

Parameter	Symbol	Conditions	Min.	Typ.	Max.	Units
Acoustic Specifications						
Sensitivity		1 kHz, 94 dB SPL	-41	-38	-35	dBV
Signal-to-Noise Ratio	SNR	94 dB SPL at 1 kHz signal, 20Hz to 20kHz, A-weighted Noise		62		dB(A)
Signal-to-Noise Ratio Voice Band	SNR	94 dB SPL at 1 kHz signal, 20Hz to 8kHz, A-weighted Noise		64		dB(A)
Total Harmonic Distortion	THD	94 dB SPL		0.1		%
Acoustic Overload Point	AOP	10.0% THD		127		dB SPL
Roll Off Frequency		-3db at 1KHz		85		Hz
Directivity			Omni			
Polarity		Increase in sound pressure	Increase in output voltage			
Electrical Specifications						
Supply Voltage			1.6	1.8	3.6	V
Supply Current		$V_{Supply} \leq 3.6\text{ V}$ (TBR)		165		$\mu\text{A}$
Power Supply Rejection Ratio	PSRR	VDD = 1.8, 1kHz, 200mV <sub>PP</sub> Sine wave		55		dB
Power Supply Rejection	PSR	VDD = 1.8, 217Hz, 100mV <sub>PP</sub> square wave, 20 Hz – 20kHz, A-weighted		-85		dB(A)
Output Impedance	Z <sub>OUT</sub>			400		$\Omega$
Output DC Offset				0.8		V
Startup Time				100		$\mu\text{S}$

## Absolute Maximum Ratings

Parameter	Rating	Units
Supply Voltage	-0.3 to +3.6	V
Sound Pressure Level	160	dB re 20 $\mu$ Pa
Operating Temperature Range	-40 to +85	$^{\circ}$ C
Storage Temperature Range	-55 to +150	$^{\circ}$ C
Mechanical Shock	10,000g per IEC 60028-2-27:2008	
Vibration	Per MIL-STD 883E, 2007.2	

## Typical Performance Characteristics

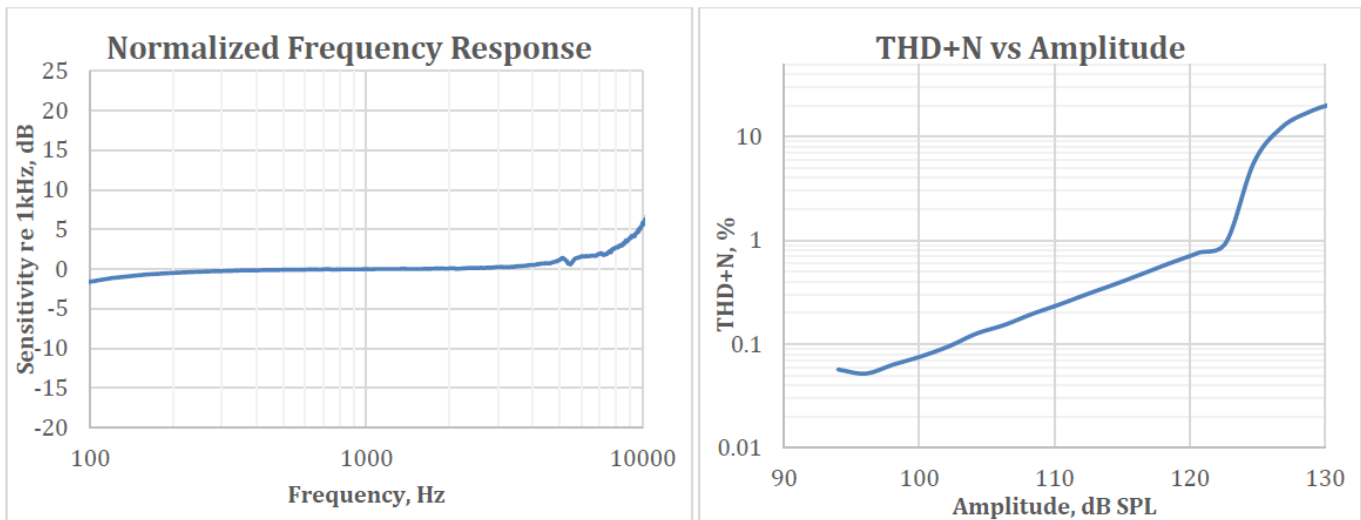

## Environmental Robustness

IP adherence is evaluated by 1 kHz Sensitivity spec post stress

Ingress Protection Type	Description
Dust Resistance	IP5X;
Water Immersion	IPX7; 2 hours drying time, normal dry environment

## Reliability Specifications

Stress Test	Description
Temperature Cycling Test	-40°C to +125°C, 850 cycles
High Temperature Operating Life	+125°C, 1000 hours, biased
High Temperature Storage	+125°C, 1000 hours, unbiased
Temperature Humidity Bias	+85°C, 85% RH, 1000 hours, biased
Reflow	3 reflow cycles with peak temperature of +260°C
ESD-HBM	3 discharges, all pins, ± 2kV
ESD-CDM	3 discharges, all pins, ± 800V
ESD-LID/GND	3 discharges to lid, ± 8kV
ESD-MM	3 discharges, all pins, ± 200V
ESD-Air Discharge	3 discharges, ± 15kV

## Applications Information

Recommended drive circuit and external components.

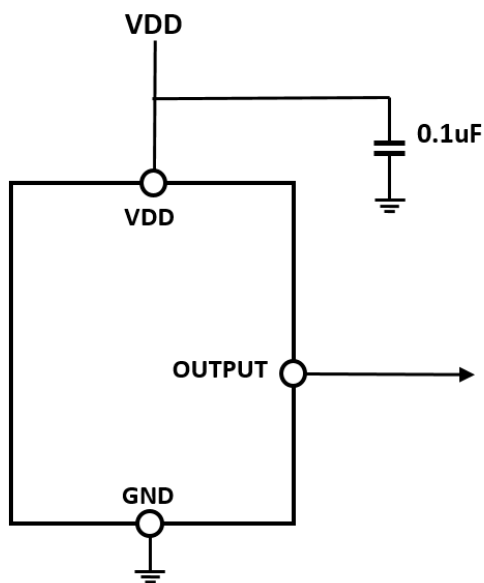

## Solder Reflow Profile

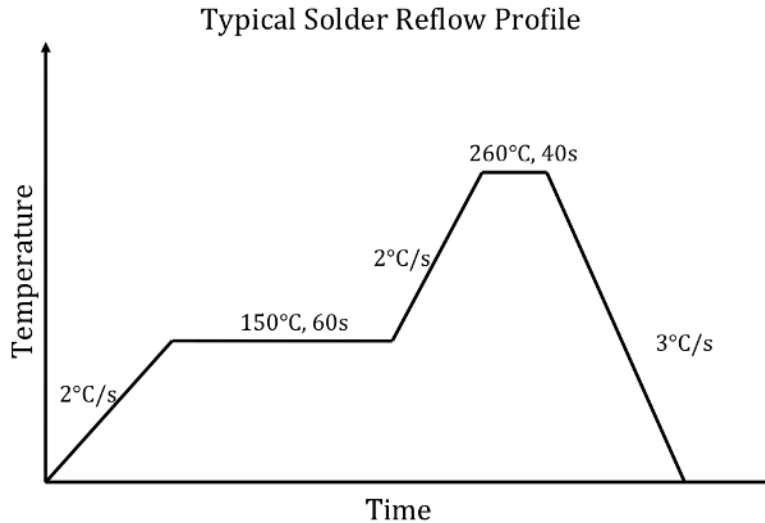

## Handling Instructions

The Piezo MEMS microphone is very robust to harsh environments such as dust and moisture. However, to avoid mechanical damage to the microphone, we recommend using appropriate handling procedures when manually handling the parts, or when using pick-and-place equipment. The following guidelines will help to avoid damage:

- Do not apply a vacuum to the bottom side of the microphone. A vacuum pen may be used with care on the top side only.
- Do not apply very high air pressure over the sound port hole.
- Do not insert any large particles or objects in the sound port hole. The microphone is resistant to small particles per IP5X specification.
- Do not board wash or clean after the reflow process or expose the sound port to harsh chemicals.
- Do not cover the sound port with tape during the solder reflow process.

## Dimensions and Pin Layout

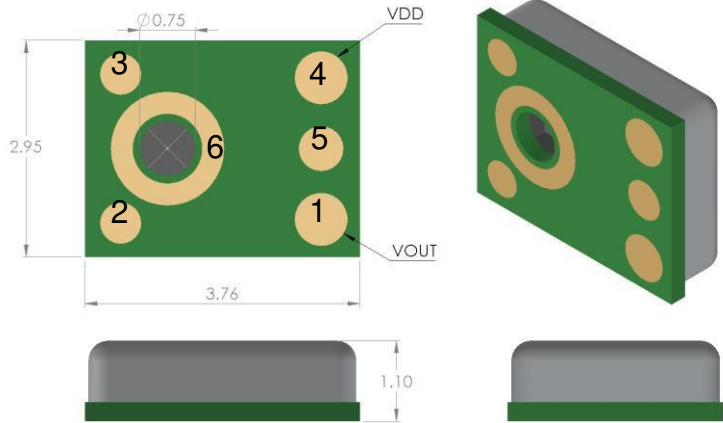

Pin Number	Pin Name	Description
1	V <sub>OUT</sub>	Analog Output Voltage
2	GND	Ground
3	GND	Ground
4	V <sub>DD</sub>	Power Supply
5	GND	Ground
6	GND	Ground

## PCB Design and Land Pattern Layout

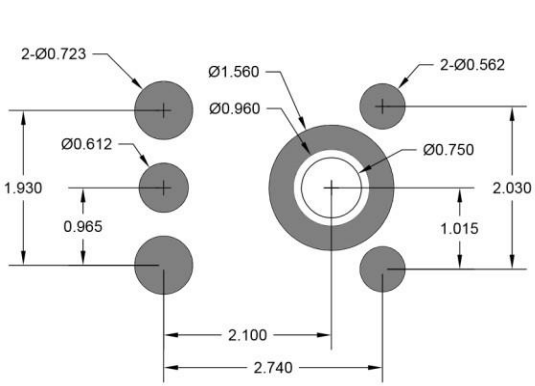

PCB Land Pattern

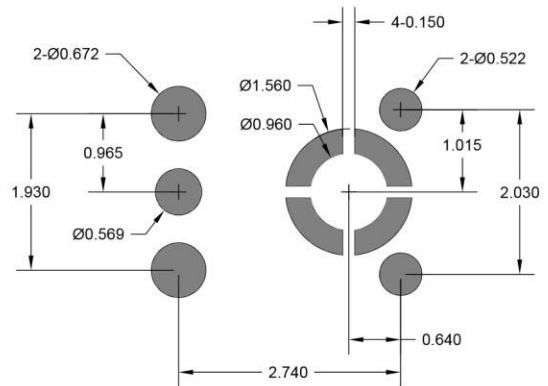

Solder Stencil Pattern

**Specifications Revisions**

<b>Revision</b>	<b>Description</b>	<b>Date</b>
-	Released from Engineering	4/3/2017
A	Revised AOP from 125 to 127 dB	12/7/2017

**Note:**

1. All dimensions are in millimeters.
2. Specifications subject to change or withdrawal without notice.
3. This part is RoHS 2011/65/EU Compliant.