

**NOTES:**

1. ALL DIMENSIONS ARE REFERENCE.

2. MATERIALS:

- C HOUSING: ABS OR PBT, UL-94HB, BLACK
- C COLOR INSERTS: POM OR PBT, UL-94HB
- C INSULATORS: POM OR PBT, UL-94HB
- SHELL & SLEEVE TERMINAL: COPPER ALLOY, NICKEL OR GOLD PLATED
- TIP TERMINALS: COPPER ALLOY, TIN PLATED
- FRONT PLATES: COPPER ALLOY, NICKEL PLATED

3. THIS PART IS RoHS COMPLIANT

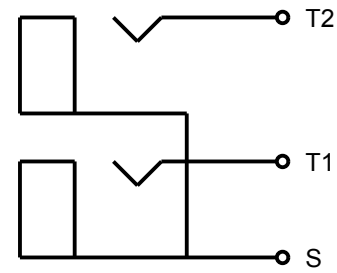

**SCHEMATIC**  
TYP (3) JACKS

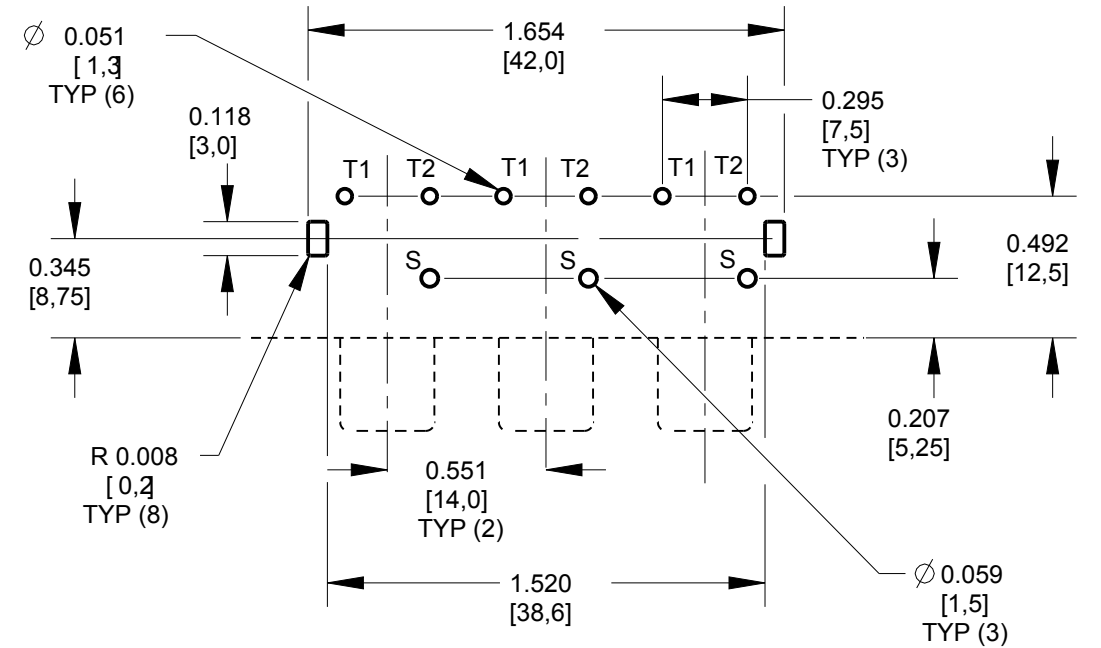

**P.C. BOARD LAYOUT**  
COMPONENT SIDE

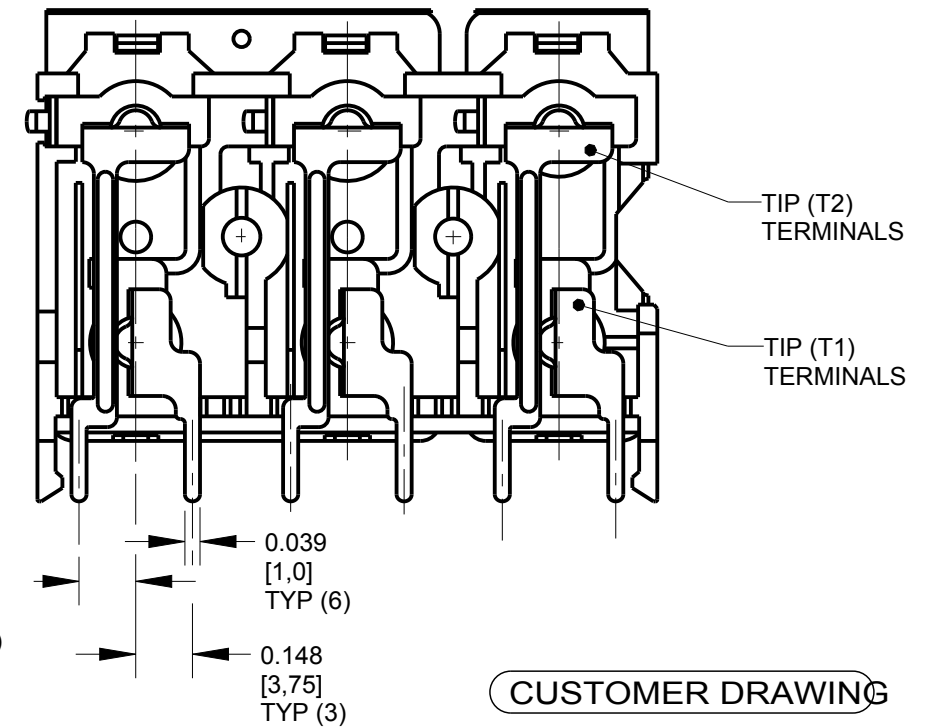
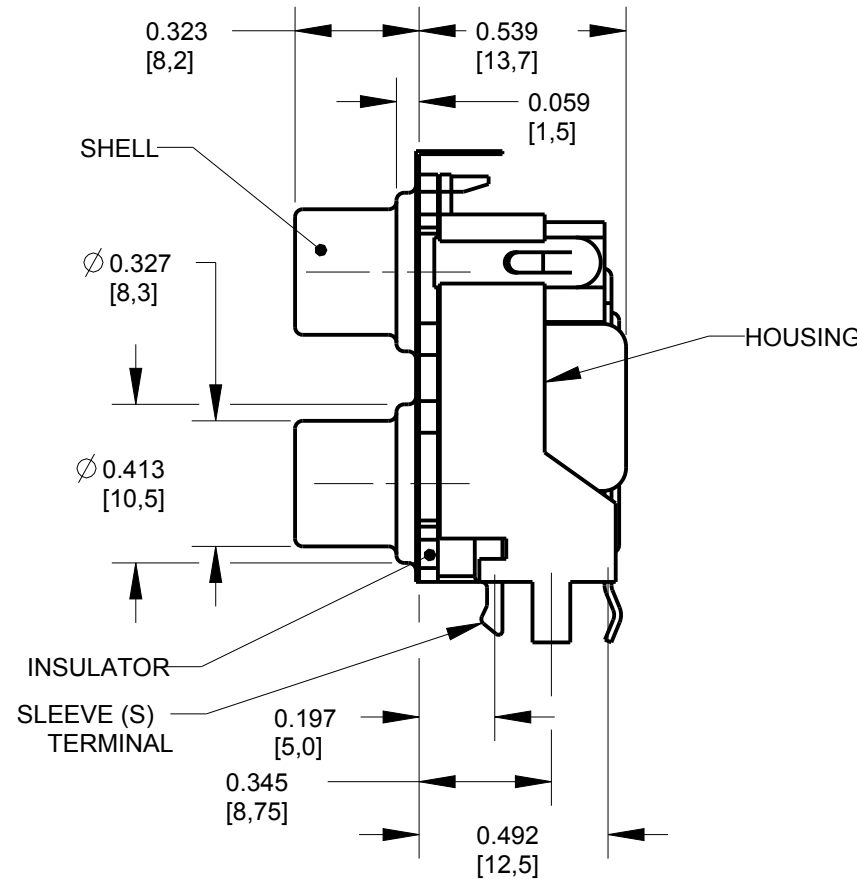
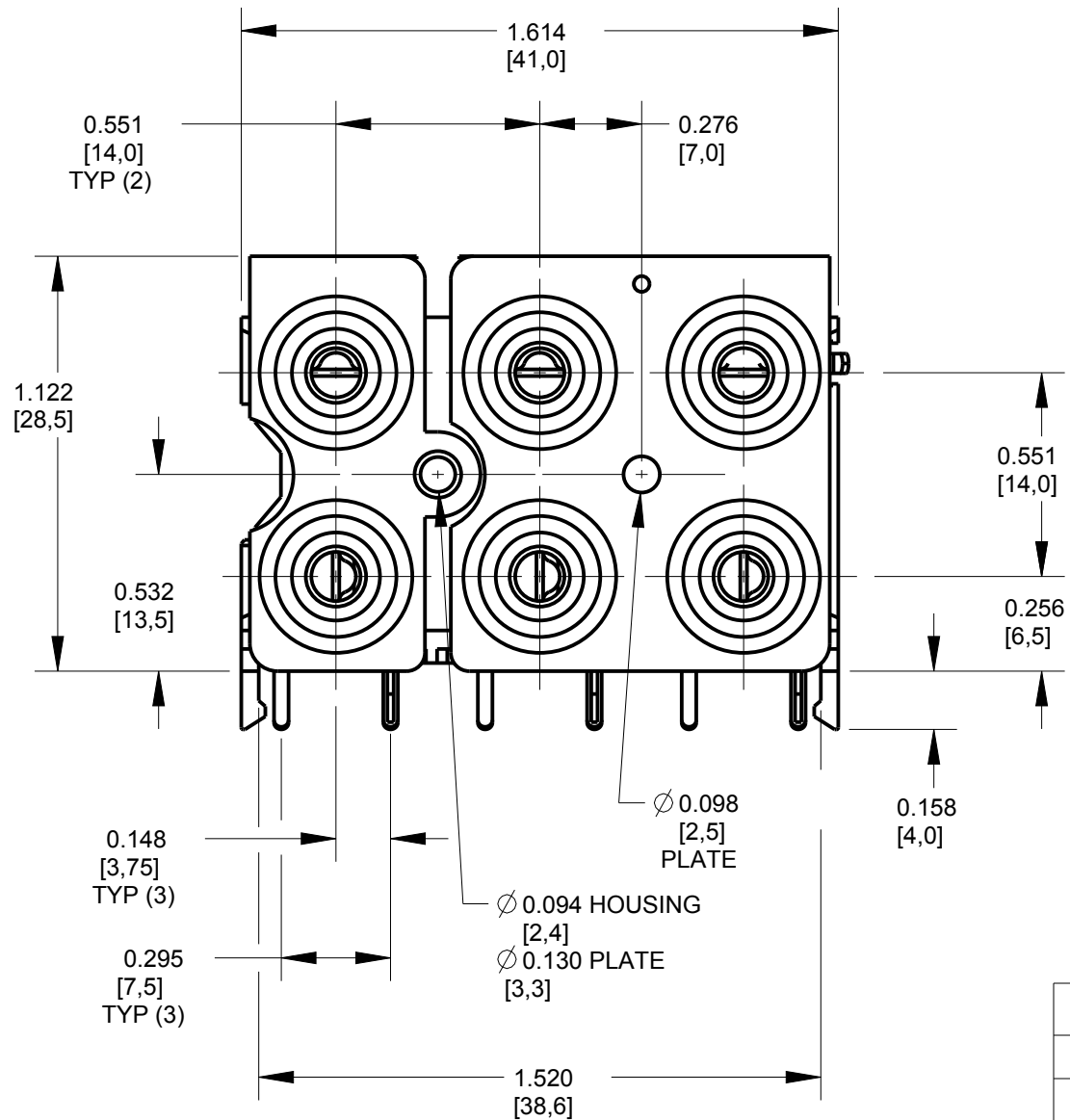

**CUSTOMER DRAWING**

REV	ECO NUMBER	DATE	BY	APVD
C	27929	08-17-17	PC	TJK
B	25610	4-11-07	TJK	TJK
A	25181	1-12-06	JL	TJK

★ STAR SYMBOL DENOTES CRITICAL DIMENSION

**UNLESS OTHERWISE SPECIFIED**

1. ALL DIMENSIONS IN INCHES  
 -TWO PLACE DECIMALS ±0.01  
 -THREE PLACE DECIMALS ±0.005  
 -ANGLES ±1°  
 -ALL DIA. CONCENTRIC WITHIN 0.005 T.I.R.

2. FEATURES ON THE SAME CENTERLINE MUST BE ALIGNED WITHIN ±0.002

3. REMOVE ALL BURRS

**DO NOT SCALE DRAWING**

THIS DRAWING DESCRIBES A DESIGN CONSIDERED PROPRIETARY IN NATURE, DEVELOPED AND MANUFACTURED BY SWITCHCRAFT INC. AND IS RELEASED ON A CONFIDENTIAL BASIS FOR IDENTIFICATION PURPOSES ONLY.				
SIZE	WIDTH	MULT	LBS/M	TEMPER
FINISH		MATERIAL		
SPEC No.		SPEC No.		
FIRST USED ON		SCALE		
		2:1		
DATE DRAWN	BY	CHKD	APVD	
12-Jan-06	JL	TJK	TJK	
		1-12-06	1-12-06	
NAME		PART No.		
PHONO JACK, RIGHT ANGLE, 6 POS. SCREW MOUNT, SHIELDED, RoHS		PJRAS3X2S__X SERIES		
SHEET 1 OF 2				REV
				C

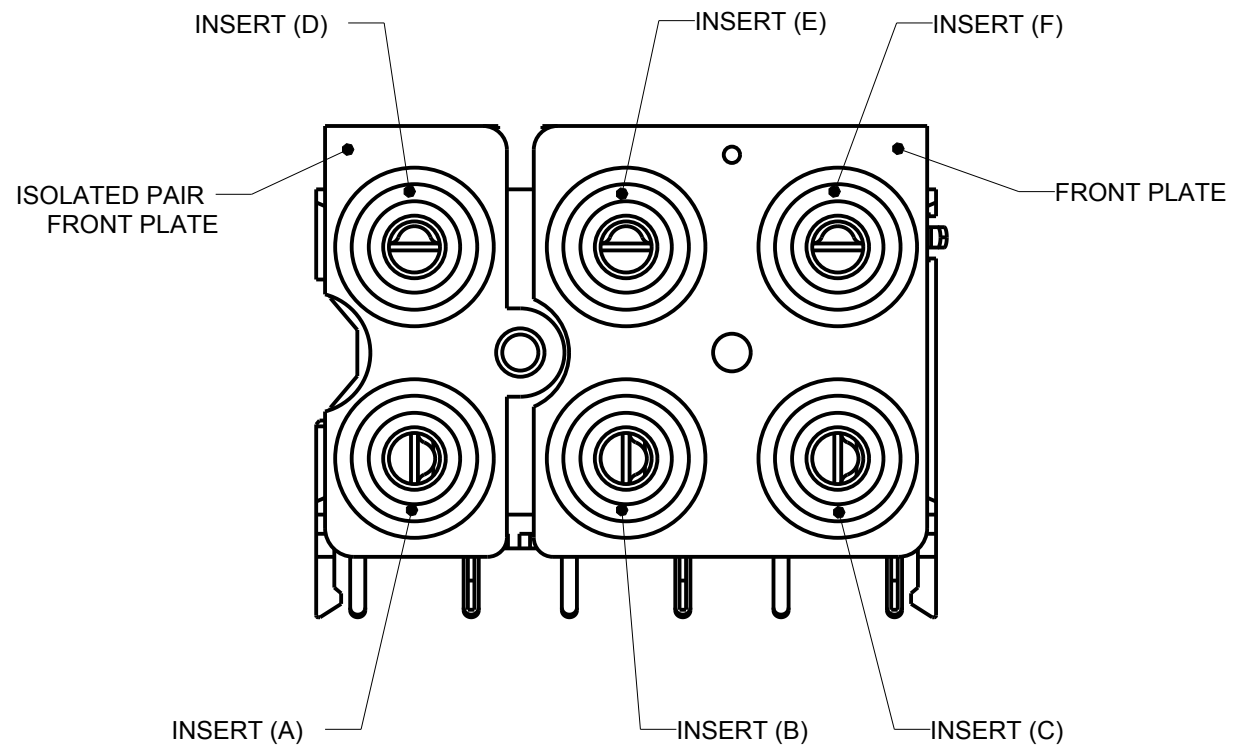

FIGURE 1

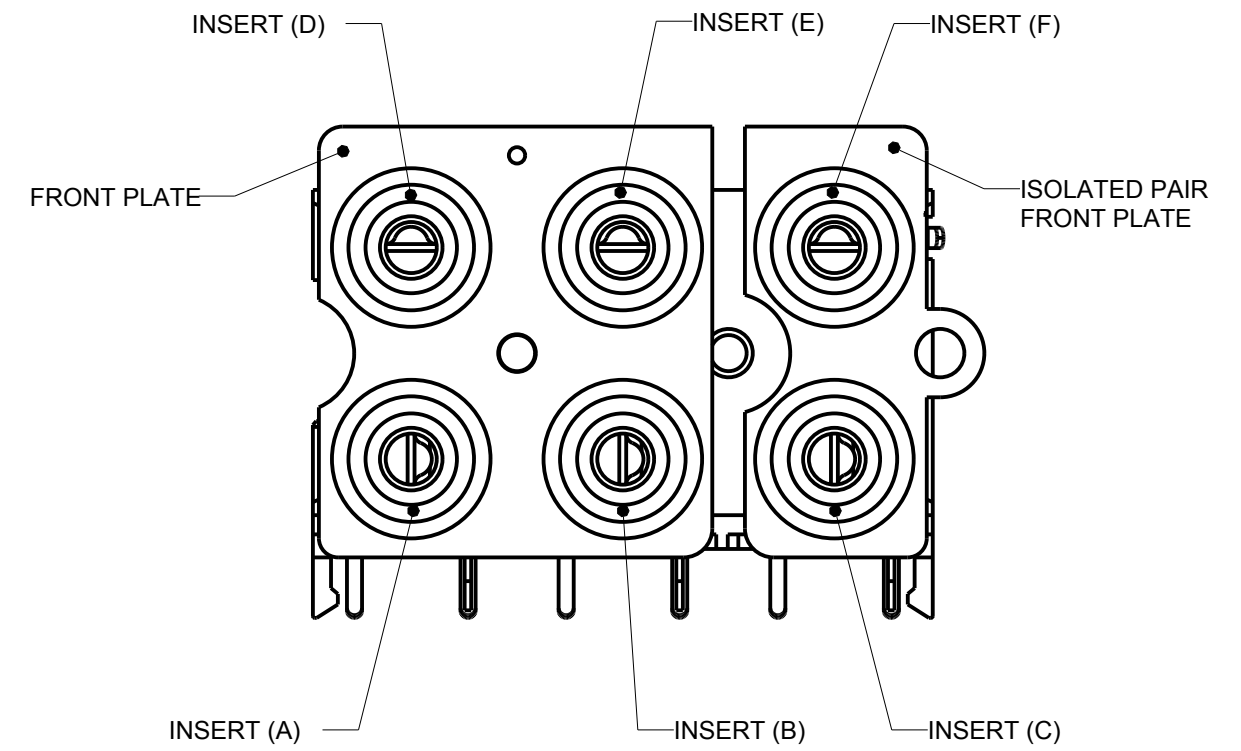

FIGURE 2

PART NUMBER	INSERT COLOR	INSERT COLOR	INSERT COLOR	ISOLATED PAIR FRONT PLATE LOCATIONS	SHELL AND SLEEVE TERMINAL FINISH
	D	E	F		
	A	B	C		
PJRAS3X2S01X	WHITE	WHITE	WHITE	FIGURE 1	NICKEL PLATED
	RED	RED	RED		
PJRAS3X2S01AUX	WHITE	WHITE	WHITE	FIGURE 1	GOLD PLATED
	RED	RED	RED		
PJRAS3X2S02X	RED	WHITE	YELLOW	FIGURE 1	NICKEL PLATED
	RED	WHITE	YELLOW		
PJRAS3X2S02AUX	RED	WHITE	YELLOW	FIGURE 1	GOLD PLATED
	RED	WHITE	YELLOW		
PJRAS3X2S03X	RED	WHITE	YELLOW	FIGURE 2	NICKEL PLATED
	RED	WHITE	YELLOW		
PJRAS3X2S04X	WHITE	WHITE	WHITE	FIGURE 1	NICKEL PLATED
	YELLOW	YELLOW	YELLOW		
B PJRAS3X2S05X	RED	GREEN	BLUE	FIGURE 1	NICKEL PLATED
	RED	GREEN	BLUE		

CUSTOMER DRAWING

SCALE 2:1	<b>Switchcraft</b> <sup>®</sup>	SHEET 2 OF 2
DATE DRAWN 12-Jan-06		
DRAWN BY JL	PART No. PJRAS3X2S__X SERIES	REV C