

MODEL LIBT - LIBRA SERIES TIMERS (LCD & LED)



CAUTION: Read complete instructions prior to installation and operation of the unit.



CAUTION: Risk of electric shock.

- ONE OR TWO PRESET VERSIONS
- 11 SELECTABLE TIME RANGES
- 0.5" (12.7 mm) HIGH LIQUID CRYSTAL DISPLAY OR 0.4" (10.2 mm) HIGH LED DISPLAY
- SOLID-STATE CURRENT SINK OUTPUT(S)
- FORM C RELAY OUTPUT(S)
- PROGRAMMABLE TIMED OUTPUT (0.01 sec to 99.99 sec.)
- SIMPLE FRONT PANEL FOR PROGRAMMING EASE
- MEETS DIN PANEL MOUNT SPECIFICATIONS
- REMOTE RESET CAPABILITY
- INSTANTANEOUS & DELAYED CONTACTS
- NON-VOLATILE MEMORY (E²PROM)
- SEALED FRONT PANEL CONSTRUCTION (NEMA 4/IP65)
- ABILITY TO LOCK OUT FRONT PANEL FUNCTIONS
- FRONT PANEL RESET ENABLE/DISABLE

DESCRIPTION

The Libra Series of presettable timers is an economical and reliable solution to one or two preset timing requirements. The LIBT1 and LIBT1E are the single preset timer versions and the LIBT2 and LIBT2E are the dual preset timer versions. All four units have a solid-state output and a form C relay output for each preset. These units feature a full complement of control inputs, programmable timed output values, non-volatile memory and many other features which will satisfy most any single or dual preset timer requirement.

The Libra Timers have two main timing actions, Reset to Zero (RTZ) [Time Up] and Reset to Preset (RTP) [Time Down]. With RTZ, the timer resets to zero, times up, and activates the outputs when the preset value(s) are reached. When RTP is used, the unit starts at the preset value, times down, and activates the output when zero is reached (single preset unit). For the dual preset version, the time starts at preset 2 and times toward zero. Output 1 fires when the preset 1 value is reached and output 2 fires when the time reaches zero. There are ten modes of operation for the single preset unit and sixteen modes of operation for the dual preset unit.

The Libra Timers also have eleven different selectable time range values. These include: hours, minutes, or seconds; tenths of hours, minutes, or seconds; hundredths of hours, minutes, or seconds; and two chronometer time functions of minutes and seconds; and hours and minutes.

The timed output is programmed through the front panel buttons and can be programmed from 0.01 sec. to 99.99 sec. (The unit's timed output is set at the factory to be 0.1 sec.) The Libra timers have an internal non-volatile memory device which eliminates the need for battery back-up. When input power is lost, this device will maintain all data necessary for system operation. A Program Disable terminal is present, which is used to prevent accidental changes or tampering by unauthorized personnel to the preset(s) or timed output value(s). The front panel reset button can also be enabled or disabled by a rear panel DIP switch. These timers also have an on-line self-test, which checks all display driver and micro-processor hardware. The self-test can be run at any time without losing time or missing preset value(s).

Power, input, and output connections are made via removable terminal blocks located at the rear of the unit. These blocks can accept one #14 AWG stripped wire. DIP switches at the rear of the unit are used to set the time ranges and to set the desired operating modes.

The Libra Series timers have a metal die-cast front bezel, which is sealed, and meets NEMA 4/IP65 specifications for wash-down and/or dust when properly installed. Mounting clips are provided for easy panel installation.

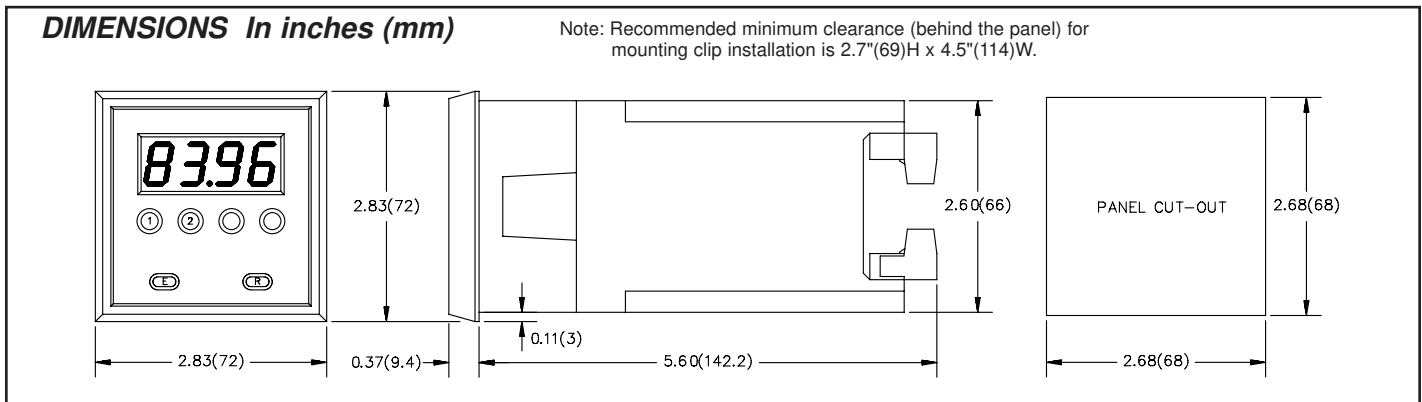

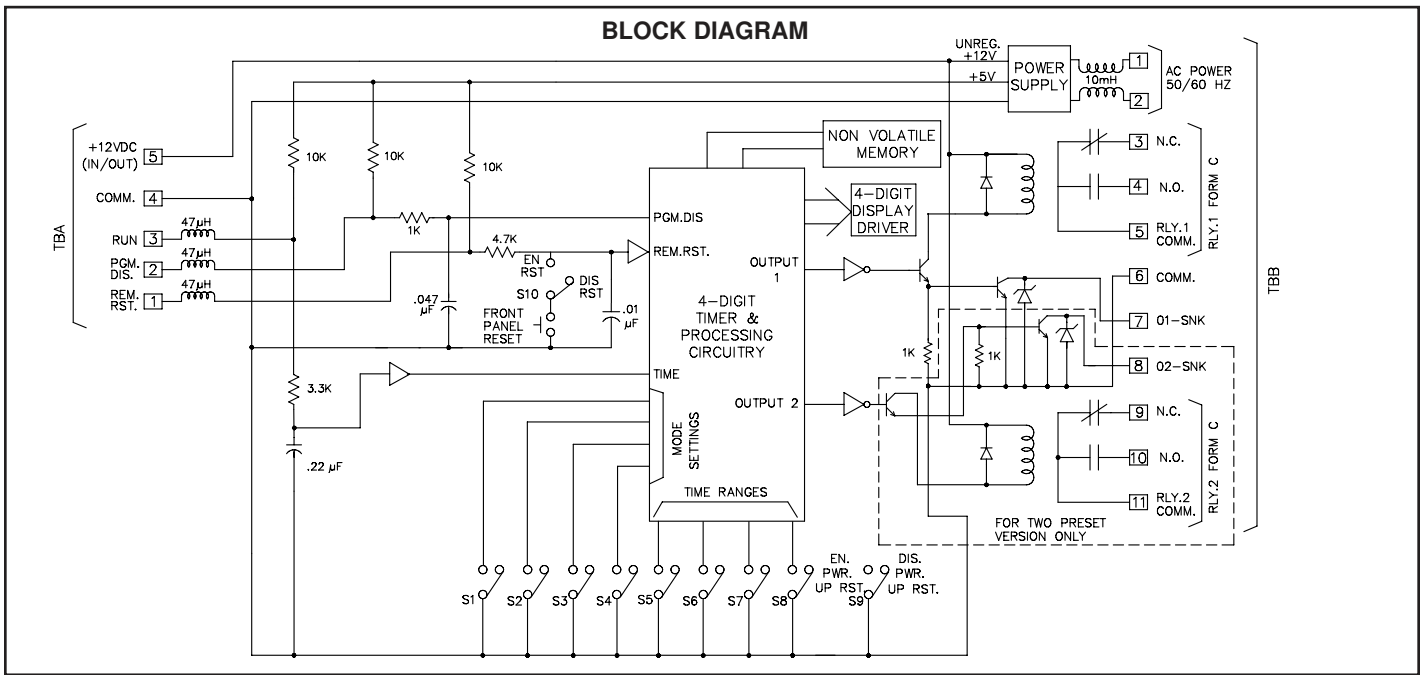

SPECIFICATIONS

- 1. **DISPLAY:**
4-digit, 0.5" (12.7 mm) high LCD display.
4-digit, 0.4" (10.2 mm) high LED display.
- 2. **POWER REQUIREMENTS:**
AC Operation: 115/230 VAC (±10%), 50/60 Hz, 6 VA (LCD) or 9 VA (LED).
DC Operation: 11 to 14 VDC @ 0.2A max (LCD) or 0.3 A max (LED).
- 3. **SENSOR POWER:** 10 to 16 VDC @ 150 mA.
- 4. **RUN INPUT:** Can accept switch contact closure and NPN Open Collector outputs and similar types of current sinking inputs. $V_{IL} = 1$ V max., internally pulled up to 5 VDC through a 10 KΩ resistor ($I_{SNK} = 0.5$ mA). Response time = 5 msec to 15 msec. (These units operate with VCM [E-H] modules.)
- 5. **TIME ACCURACY:** ±0.01%
- 6. **CONTROL INPUTS:**
Remote Reset: Active low ($V_{IL} = 1$ V max.), internally pulled up to 5 VDC through a 10 KΩ resistor ($I_{SNK} = 0.5$ mA). Response time = 10 msec. A low will reset the unit and deactivate the outputs.
Program Disable: Active low ($V_{IL} = 0.5$ V max.), internally pulled up to 5 VDC through a 10 KΩ resistor ($I_{SNK} = 0.5$ mA). A low will inhibit the changing of presets and timed outputs, as well as the testing of outputs in self-test.
- 7. **OUTPUTS:**
Solid-State: Current sinking NPN open collector transistors. $I_{SNK} = 100$ mA max. $V_{OH} = 30$ VDC max. (Internal Zener diode protection). One solid-state output for each preset level. $V_{OL} = 1$ VDC max. @ 100 mA.
Relay(s): Form C contacts max. rating 5 amps @ 120/240 VAC, 28 VDC (resistive load), 1/8 H.P. @ 120 VAC (inductive load). The operate time is 5 msec nominal and the release time is 3 msec nominal.
Relay Life Expectancy: 100,000 cycles at max. rating. (As load level decreases, life expectancy increases.)
Programmable Timed Output: The timed output can be programmed from 0.01 sec to 99.99 sec, ±0.01% - 10 msec. The timed output is set for 0.1 sec at the factory.
- 8. **MEMORY RETENTION:** The Libra Timers have a "no power E²PROM" which maintains all information when the input power is removed. The life expectancy of this device is at least 10,000 power down cycles and length of memory retention for a single power down can be as long as 10 years.
- 9. **INPUT, POWER, AND OUTPUT CONNECTIONS:** There are two plug-in, compression type, barrier strips located at the rear of the unit. These strips can be removed from the rear of the unit for ease of wiring. After wiring is complete, the connector can be plugged back into the unit.
- 10. **CERTIFICATIONS AND COMPLIANCES:**

SAFETY

- Type 4 Indoor Enclosure rating (Face only), UL50
- IEC 1010-1, EN 61010-1: Safety requirements for electrical equipment for measurement, control, and laboratory use, Part 1.
- IP65 Enclosure rating (Face only), IEC529

ELECTROMAGNETIC COMPATIBILITY

Immunity to EN 50082-2

Electrostatic discharge	EN 61000-4-2	Level 2; 4 Kv contact ¹ Level 3; 8 Kv air
Electromagnetic RF fields	EN 61000-4-3	Level 3; 10 V/m 80 MHz - 1 GHz
Fast transients (burst)	EN 61000-4-4	Level 4; 2 Kv I/O ² Level 3; 2 Kv power
RF conducted interference	EN 61000-4-6	Level 3; 10 V/rms ² 150 KHz - 80 MHz
Power frequency magnetic fields	EN 61000-4-8	Level 4; 30 A/m

Emissions to EN 50081-2

RF interference	EN 55011	Enclosure class B Power mains class B
-----------------	----------	--

Note:

- 1. Metal bezel of unit connected with ground lead from rear bezel screw to metal mounting panel.
- 2. When the unit is DC powered from terminal TBA pin 5 (common) and terminal TBB pin 6 (+12 VDC) a power line filter was installed, RLC #LFIL0000 or equivalent, so as not to impair the function of the unit.

Refer to the EMC Installation Guidelines for additional information.

11. ENVIRONMENTAL CONDITIONS:

- Operating Temperature:** 0°C to 50°C
- Storage Temperature:** -40°C to 70°C
- Operating and Storage Humidity:** 85% max (non-condensing) from 0 to 50°C
- Altitude:** Up to 2000 meters

- 12. **CONSTRUCTION:** Metal die-cast bezel with black, high impact plastic insert. Front panel meets NEMA 4/IP65 requirements for indoor use when properly installed. (Panel gasket and mounting clips included with unit.) Installation Category II, Pollution Degree 2
- 13. **WEIGHT:** 1.5 lbs. (0.68 kg) [LCD], 1.75 lbs. (0.79 kg) [LED]

SELECTION OF MODES OF OPERATION, TIME RANGE VALUE, POWER-UP RESET, & FRONT PANEL RESET

The selection of Modes of Operation, Time Range, Power-Up Reset, and Front Panel Reset is accomplished by a ten-position DIP switch, located at the rear of the unit, in the upper right-hand corner. DIP switches 1-4 are used to set the desired mode of operation, while DIP switches 5-8 are used to determine the time range setting. DIP switch 9 is used to determine whether the unit, on power-up, is to restore or reset the time value. When this switch is up, the time value, displayed before power loss, will be restored and will be operated on as before power loss. When the switch is down, the unit will reset the time value to either zero (RTZ) or to the preset value (RTP) when input power is restored. DIP switch 10 is used to enable or disable the front panel reset button. When the switch is up, the front panel reset button is disabled. When the switch is down, the front panel reset button is enabled. The selection of Mode of Operation will be discussed first followed by the selection of Time Range Value.

MODES OF OPERATION

Mode settings of the switches are shown to the right of the text below. The mode number corresponds to a binary code, represented by the DIP switch positions. When the switch is "UP", it is equivalent to a zero. When the switch

is "DOWN", it is equivalent to a one. The mode switch settings can be easily observed from the panel front by using the self-test. Near the end of self-test, the state of these mode switches are displayed.

MODES OF OPERATION FOR SINGLE PRESET LIBRA TIMER

MODE 0 LATCH OUTPUT AT PRESET, MANUAL RESET TO ZERO, TIME STOPS AT PRESET (ACCUMULATING DELAY ON MAKE, TIME UP)

In this mode, as the unit times up from zero, the output will latch-on when the preset is reached. Also, the unit will stop timing when preset is reached. When a manual reset occurs, the unit will Reset to Zero and the output if latched on, will unlatch.



To use as a DELAY ON MAKE timer, set the preset value to the desired delay value. When "RUN" is at a low level, time will increment. The output will activate when the preset is reached. To recycle use 1) reset, or 2) set the power-up reset switch to enable, then remove and reapply input power.

MODE 1 LATCH OUTPUT AT PRESET, MANUAL RESET TO ZERO, TIME CONTINUES AT PRESET (ACCUMULATING DELAY ON MAKE, TIME UP)

In this mode, as the unit times up from zero, the output will latch on when the preset is reached. Time will continue to accumulate after the preset is reached. When manual reset occurs, the unit will Reset to Zero, and the output, if latched on, will unlatch.



To use as a DELAY ON MAKE timer, follow the description under Mode 0.

MODE 2 & 3 - ☆☆

MODE 4 TIMED OUTPUT AT PRESET, MANUAL RESET TO ZERO, TIME STOPS AT PRESET

In this mode, as the unit times up from zero, the output will turn on when the preset is reached. The output will turn off after its programmed time value has occurred. Also, the unit will stop timing when the preset is reached. When a manual reset occurs, the unit will Reset to Zero. Manual reset will terminate the timed output, if the output is still turned on.



MODE 5 TIMED OUTPUT AT PRESET, AUTOMATIC RESET TO ZERO AFTER TIMED OUTPUT (OFF/ON RECYCLING, TIME UP)

In this mode, as the unit times up from zero, the output will turn on when the preset is reached. The output will turn off after its programmed time value has occurred. Also, at the end of the timed output, the unit will automatically Reset to Zero and start the cycle over. Manual reset will turn off the output, if turned on, and reset the time to zero.



When used as an OFF/ON RECYCLING timer, the total cycle time is the sum of the preset value plus the programmed timed output value. The ON delay value is equal to the programmed timed output value.†† When "RUN" is at a low level, time will increment. The output (ON delay) will activate when the preset is reached. The unit will recycle at the end of the timed output.

MODE 6 TIMED OUTPUT AT PRESET, AUTOMATIC RESET TO ZERO AT PRESET † (OFF/ON RECYCLING, TIME UP)

In this mode, as the unit times up from zero, the output will turn on when the preset is reached. The output will turn off after its programmed time value has occurred. Also, when the preset is reached, the unit will automatically Reset to Zero and start the cycle over. (The output will remain on until its time value has occurred.) Manual reset will turn off the output, if turned on, and reset the time to zero.



When used as an OFF/ON RECYCLING timer, the total cycle time is the preset value. The ON delay value is equal to the programmed timed output value.†† When "RUN" is at a low level, time will increment. The output (ON delay) will activate when the preset is reached. The unit will recycle at the beginning of the timed output.

MODE 7 - ☆☆

☆ - Manual reset, either by front panel reset (if enabled) or remote reset, is always active, and will override any condition or state of the timer.
☆☆ - These modes are not applicable to the single preset Libra timer (they are used only for the two preset timer unit).

MODE 8 LATCH OUTPUT AT ZERO, MANUAL RESET TO PRESET TIME STOPS AT ZERO (ACCUMULATING DELAY ON MAKE, TIME DOWN)

In this mode, as the unit times down from preset, the output will latch on when zero is reached. Also, the unit will stop timing when zero is reached. When a manual reset occurs, the unit will Reset to Preset and the output, if latched on, will unlatch.



To use as a DELAY ON MAKE timer, set the preset value to the desired delay value. When "RUN" is at a low level, time will decrement. The output will activate when the zero is reached. To recycle use 1) reset, or 2) set the power-up reset switch to enable, then remove and reapply input power.

MODE 9 LATCH OUTPUT AT ZERO, MANUAL RESET TO PRESET, TIME CONTINUES AT ZERO (ACCUMULATING DELAY ON)

In this mode, as the unit times down from preset, the output will latch on when zero is reached. Time will continue to accumulate after zero is reached. When a manual reset occurs, the unit will Reset to Preset, and the output, if latched on, will unlatch.



To use as a DELAY ON MAKE timer, follow the description under Mode 8.

MODE 10 & 11 - ☆☆

MODE 12 TIMED OUTPUT AT ZERO, MANUAL RESET TO PRESET, TIME STOPS AT ZERO

In this mode, as the unit times down from preset, the output will turn on when zero is reached. The output will turn off after its programmed time value has occurred. Also, the unit will stop timing when zero is reached. When a manual reset occurs, the unit will Reset to Preset. Manual reset will terminate the timed output, if the output is still turned on.



MODE 13 TIMED OUTPUT AT ZERO, AUTOMATIC RESET TO PRESET AFTER TIMED OUTPUT (OFF/ON RECYCLING, TIME DOWN)

In this mode, as the unit times down from preset, the output will turn on when zero is reached. The output will turn off after the programmed time value has occurred. Also, at the end of the timed output, the unit will automatically Reset to Preset and start the cycle over. Manual reset will turn off the output, if turned on, and reset the time to the preset value.



When used as an OFF/ON RECYCLING timer, the total cycle time is equal to the sum of the preset value plus the programmed timed output value. The ON delay value is equal to the programmed timed output value.†† When "RUN" is at a low level, time will decrement. The output (ON delay) will activate when zero is reached. The unit will recycle at the end of the timed output.

MODE 14 TIMED OUTPUT AT ZERO, AUTOMATIC RESET TO PRESET AT ZERO † (OFF/ON RECYCLING, TIME DOWN)

In this mode, as the unit times down from preset, the output will turn on when zero is reached. The output will turn off after its programmed time value has occurred. Also, when zero is reached, the unit automatically resets the time to the preset value and starts the cycle over. Manual reset will turn off the output, if turned on, and reset the timer to the preset value.



When used as an OFF/ON RECYCLING timer, the total cycle time is the preset value. The ON delay value is equal to the programmed timed output value.†† When "RUN" is at a low level, time will decrement. The output (ON delay) will activate when zero is reached. The unit will recycle at the beginning of the timed output.

MODE 15 - ☆☆

† - The timed output value must be less than the value required to time from the reset condition to the preset point. Otherwise, the output will appear to be latched on.

†† - The maximum ON delay is 99.99 seconds.

POWER-UP DIAGNOSTICS

The Libra timers have internal diagnostics which will check the stored data during power-up. When the data is saved (power-down), computations are made with these values. The result of these computations is stored in the memory to serve as a check against possible error. Then on power-up, these same computations are repeated on the stored data. If these results do not agree with

the stored results, then a "P" will appear on the right side of the display. Normal operation of the unit will continue while this "P" displayed. To remove the "P" from the display, press the "E" button. Then check programmed values to be certain they are correct.

MODES OF OPERATION FOR DUAL PRESET LIBRA TIMER

MODE 0 LATCH OUTPUTS AT PRESETS, MANUAL RESET TO ZERO, TIME STOPS AT PRESET 2 (INSTANTANEOUS & TIME DELAY CONTACT, TIME UP)

In this mode, as the unit times up from zero, output 1 will latch on when preset 1 is reached and output 2 will latch on when preset 2 is reached. The unit will stop timing when preset 2 is reached. This mode also has an input tracking feature (INSTANTANEOUS CONTACT) where if preset 1 is set to zero, output 1 will turn on when the input is activated, and it will turn off when the input is deactivated. (Output 2 is the TIME DELAY CONTACT.) When a manual reset occurs, the unit will Reset to Zero and the outputs, if latched on, will unlatch.



To use as an INSTANTANEOUS AND TIME DELAY CONTACT timer, set preset 1 value to zero and set preset 2 value to the desired delay value. When "RUN" is at a low level, time will increment and output 1 will be activated. Output 2 (TIME DELAY CONTACT) will activate when preset 2 is reached. To recycle use 1) reset, or 2) set the power-up reset switch to enable, then remove and reapply input power.

MODE 1 LATCH OUTPUTS AT PRESETS, MANUAL RESET TO ZERO, TIME CONTINUES AT PRESET 2 (INSTANTANEOUS & TIME DELAY CONTACT, TIME UP)

In this mode, as the unit times up from zero, output 1 will latch on when preset 1 is reached, and output 2 will latch on when preset 2 is reached. Time will continue to accumulate after preset 2 is reached. This mode also has an input tracking feature (INSTANTANEOUS CONTACT) where if preset 1 is set to zero, output 1 will turn on when the input is activated, and it will turn off when the input is deactivated. (Output 2 is the TIME DELAY CONTACT.) When manual reset occurs, the unit will Reset to Zero, and the outputs, if latched on, will unlatch.



To use as an INSTANTANEOUS AND TIME DELAY CONTACT timer, follow the description under Mode 0.

MODE 2 OUTPUT 1 TURN OFF AT PRESET 2, LATCH OUTPUT 2 AT PRESET 2, MANUAL RESET TO ZERO, TIME STOPS AT PRESET 2 (INTERVAL, TIME UP)

In this mode, as the unit times up from zero, output 1 will turn on when preset 1 is reached. When preset 2 is reached, output 2 will turn on and output 1 will turn off. Output 2 will remain latched on until a manual reset occurs, and the unit will stop timing when preset 2 is reached. This mode also has an input tracking feature where if preset 1 is set to zero, output 1 will turn on when the input is activated, and it will turn off when the input is deactivated. (After preset 2 is reached, output 1 will turn off and stay off, regardless of the input condition, until a manual reset occurs.) When a manual reset occurs, the unit will Reset to Zero and the outputs, if latched on, will unlatch.



To use as an INTERVAL timer, set preset 1 value to zero and set preset 2 value to the desired delay value. When "RUN" is at a low level, time will increment and output 1 will be activated. Output 1 will deactivate (regardless of the input condition) when preset 2 (TIME DELAY VALUE) is reached. To recycle use 1) reset, or 2) set the power-up reset switch to enable, then remove and reapply input power.

MODE 3 OUTPUT 1 TURN OFF AT PRESET 2, LATCH OUTPUT 2 AT PRESET 2, MANUAL RESET TO ZERO, TIME CONTINUES AT PRESET 2 (INTERVAL, TIME UP)

In this mode, as the unit times up from zero, output 1 will turn on when preset 1 is reached. When preset 2 is reached, output 2 will turn on and output 1 will turn off. Output 2 will remain latched on until a manual reset occurs, and the unit will continue to accumulate time after preset 2 is reached. This mode also has an input tracking feature where if preset 1 is set to zero, output 1 will turn on when the input is activated, and it will turn off when the input is deactivated. (After preset 2 is reached, output 1 will turn off and stay off, regardless of the input condition, until a manual reset occurs.) When manual reset occurs, the unit will Reset to Zero, and the outputs, if latched on, will unlatch.



To use as an INTERVAL timer, follow the description under Mode 2

MODE 4 TIMED OUTPUTS AT PRESETS, MANUAL RESET TO ZERO, TIME STOPS AT PRESET 2

In this mode, as the unit times up from zero, output 1 will turn on when preset 1 is reached, and output 2 will turn on when preset 2 is reached. The outputs will turn off after their respective programmed time values have occurred. Also, the unit will stop timing when preset 2 is reached. When a manual reset occurs, the unit will Reset to Zero. Manual reset will terminate the timed output, if the outputs are still turned on.



MODE 5 TIMED OUTPUTS AT PRESETS, AUTOMATIC RESET TO ZERO AFTER TIMED OUTPUT 2 † (TWO LOBE OFF/ON RECYCLING, TIME UP)

In this mode, as the unit times up from zero, output 1 will turn on when preset 1 is reached and output 2 will turn on when preset 2 is reached. The outputs will turn off after their respective programmed time values have occurred. Also at the end of timed output 2, the unit will automatically Reset to Zero and start the cycle over. Manual reset will turn off both outputs, if turned on, and reset the time to zero.



When used as an OFF/ON RECYCLING timer, the total cycle time is equal to the sum of the preset 2 value and the programmed timed output 2 value. The first lobe of the cycle will use output 1. The first ON delay value is equal to the programmed timed output 1 value. †† The second lobe of the cycle will use output 2. The second ON delay is equal to the programmed timed output 2 value. †† When "RUN" is at a low level, time will increment. Output 1 (first ON delay) will activate when preset 1 is reached, and output 2 (second ON delay) will activate when preset 2 is reached. The unit will recycle at the end of timed output 2.

MODE 6 TIMED OUTPUTS AT PRESETS, AUTOMATIC RESET TO ZERO AT PRESET 2 † (TWO LOBE OFF/ON RECYCLING, TIME UP)

In this mode, as the unit times up from zero, output 1 will turn on when preset 1 is reached and output 2 will turn on when preset 2 is reached. The outputs will turn off after their respective programmed time values have occurred. Also when preset 2 is reached, the unit will automatically reset the time to zero and start the cycle over. (Output 2 will remain on until its time value has occurred.) Manual reset will turn off both outputs, if still turned on, and reset the time to zero.



When used as an OFF/ON RECYCLING timer, the total cycle time is equal to the preset 2 value. The first lobe of the cycle will use output 1. The first ON delay is equal to the programmed timed output 1 value. †† The second lobe of the cycle will use output 2. The second ON delay is equal to the programmed timed output 2 value. †† When "RUN" is at a low level, time will increment. Output 1 (first ON delay) will activate when preset 1 is reached, and output 2 (second ON delay) will activate when preset 2 is reached. The unit will recycle at the beginning of timed output 2.

MODE 7 OUTPUT 1 TURN OFF AT PRESET 2, TIMED OUTPUT 2 AT PRESET 2, AUTOMATIC RESET TO ZERO AFTER TIMED OUTPUT 2 † (INSTANTANEOUS & TWO LOBE OFF/ON RECYCLING, TIME UP)

In this mode, as the unit times up from zero, output 1 will turn on when preset 1 is reached. When preset 2 is reached, output 2 will turn on and output 1 will turn off. Output 2 will turn off after its programmed time value has occurred. At the end of timed output 2, the unit will automatically Reset to Zero and start the cycle over. This mode also has an input tracking feature (INSTANTANEOUS CONTACT) where if preset 1 is set to zero, output 1 will turn on when the input is activated, and off when the input is deactivated. (After preset 2 is reached, output 1 will turn off and stay off, regardless of the input condition until a reset occurs.) Manual reset will turn off both outputs, if turned on, and reset the time to zero.



When used as an OFF/ON RECYCLING timer, the total cycle time is equal to the sum of the preset 2 value and the programmed timed output 2 value. The first lobe of the cycle will use output 1. The first ON delay is equal to the difference between preset 1 and preset 2 values (this is because output 1 will turn off at preset 2). The second lobe of the cycle will use output 2. The second ON delay is equal to the programmed timed output 2 value. †† When "RUN" is at a low level, time will increment. Output 1 (first ON delay) will activate when preset 1 is reached, and output 2 (second ON delay) will activate when preset 2 is reached (output 1 will deactivate when preset 2 is reached). The unit will recycle at the end of timed output 2.

✱ - Manual reset, either by front panel reset (if enabled) or remote reset, is always active, and will override any condition or state of the timer.

† - The timed output value must be less than the value required to time from the reset condition to the preset point. Otherwise, the output will appear to be latched on.

†† - The maximum ON delay is 99.99 seconds.

(Modes Cont'd)

MODES OF OPERATION FOR DUAL PRESET LIBRA TIMER (Cont'd)

MODE 8 LATCH OUTPUT AT PRESET 1 AND ZERO, MANUAL RESET TO PRESET 2, TIME STOPS AT ZERO (INSTANTANEOUS & TIME DELAY CONTACT, TIME DOWN)

In this mode, as the unit times down from preset 2, output 1 will latch on when preset 1 is reached and output 2 will latch on when zero is reached. The unit will stop timing when zero is reached. This mode also has an input tracking feature (INSTANTANEOUS CONTACT) where if preset 1 is set to zero, output 1 will turn on when the input is activated, and it will turn off when the input is deactivated. (Output 2 is the TIME DELAY CONTACT.) When a manual reset occurs, the unit will Reset to Preset and the outputs, if latched on, will unlatch.



To use as an INSTANTANEOUS AND TIME DELAY CONTACT timer, set preset 1 value to zero and set preset 2 value to the desired delay value. When "RUN" is at a low level, time will decrement and output 1 will be activated. Output 2 (TIME DELAY CONTACT) will activate when zero is reached. To recycle use 1) reset, or 2) set the power-up reset switch to enable, then remove and reapply input power.

MODE 9 LATCH OUTPUT AT PRESET 1 AND ZERO, MANUAL RESET TO PRESET 2, TIME CONTINUES AT ZERO (INSTANTANEOUS & TIME DELAY CONTACT, TIME DOWN)

In this mode, as the unit times down from preset 2, output 1 will latch on when preset 1 is reached, and output 2 will latch on when zero is reached. Time will continue to accumulate after zero is reached. This mode also has an input tracking feature (INSTANTANEOUS CONTACT) which if preset 1 is set to zero, output 1 will turn on when the input is activated, and it will turn off when the input is deactivated. (Output 2 is the TIME DELAY CONTACT.) When manual reset occurs, the unit will Reset to Preset 2 and the outputs, if latched on, will unlatch.



To use as an INSTANTANEOUS AND TIME DELAY CONTACT timer, follow the description under Mode 8.

MODE 10 OUTPUT 1 TURN OFF AT ZERO, LATCH OUTPUT 2 AT ZERO, MANUAL RESET TO PRESET 2, TIME STOPS AT PRESET 2 (INTERVAL, TIME DOWN)

In this mode, as the unit times down from preset 2, output 1 will turn on when preset 1 is reached. When zero is reached, output 2 will turn on and output 1 will turn off. Output 2 will remain latched on until a manual reset occurs, and the unit will stop timing when zero is reached. This mode also has an input tracking feature where if preset 1 is set to zero, output 1 will turn on when the input is activated, and it will turn off when the input is deactivated. (After zero is reached output 1 will turn off and stay off, regardless of the input condition, until a manual reset occurs.) When a manual reset occurs, the unit will Reset to Preset 2 and the outputs, if latched on, will unlatch.



MODE 11 OUTPUT 1 TURN OFF AT ZERO, LATCH OUTPUT 2 AT ZERO, MANUAL RESET TO PRESET 2, TIME CONTINUES AT PRESET 2 (INTERVAL, TIME DOWN)

In this mode, as the unit times down from preset 2, output 1 will turn on when preset 1 is reached. When zero is reached, output 2 will turn on and output 1 will turn off. Output 2 will remain latched on until a manual reset occurs, and the unit will continue to accumulate time after zero is reached. This mode also has an input tracking feature where if preset 1 is set to zero, output 1 will turn on when the input is activated, and it will turn off when the input is deactivated. (After zero is reached, output 1 will turn off and stay off, regardless of the input condition, until a manual reset occurs.) When manual reset occurs, the unit will Reset to Preset 2, and the outputs, if latched on, will unlatch.



MODE 12 TIMED OUTPUT AT PRESET 1 AND ZERO, MANUAL RESET TO PRESET 2, TIME STOPS AT ZERO

In this mode, as the unit times down from preset 2, output 1 will turn on when preset 1 is reached, and output 2 will turn on when zero is reached. The outputs will turn off after their respective programmed time values have occurred. Also, the unit will stop timing when zero is reached. When a manual reset occurs, the unit will Reset to Preset 2. Manual reset will terminate the timed outputs, if the outputs are still turned on.



☆ - Manual reset, either by front panel reset (if enabled) or remote reset, is always active, and will override any present condition or state of the timer.

MODE 13 TIMED OUTPUTS AT PRESET 1 AND ZERO, AUTOMATIC RESET TO PRESET 2 AFTER TIMED OUTPUT 2 † (TWO LOBE OFF/ON RECYCLING, TIME DOWN)

In this mode, as the unit times down from preset 2, output 1 will turn on when preset 1 is reached and output 2 will turn on when zero is reached. The outputs will turn off after their respective programmed time values have occurred. Also, at the end of timed output 2, the unit will automatically Reset to Preset 2 and start the cycle over. Manual reset will turn off both outputs, if turned on, and reset the time to preset 2.



When used as an OFF/ON RECYCLING timer, the total cycle time is equal to the sum of the preset 2 value and the programmed timed output 2 value. The first lobe of the cycle will use output 1. The first ON delay is equal to the programmed timed output 1 value. †† The second lobe of the cycle will use output 2. The second ON delay is equal to the programmed timed output 2 value. †† When "RUN" is at a low level, time will decrement. Output 1 (first ON delay) will activate when preset 1 is reached, and output 2 (second ON delay) will activate when zero is reached. The unit will recycle at the end of timed output 2.

MODE 14 TIMED OUTPUTS AT PRESET 1 AND ZERO, AUTOMATIC RESET TO PRESET 2 AT ZERO † (TWO LOBE OFF/ON RECYCLING, TIME DOWN)

In this mode, as the unit times down from preset 2, output 1 will turn on when preset 1 is reached and output 2 will turn on when zero is reached. The outputs will turn off after their respective programmed time values have occurred. Also when zero is reached, the unit will automatically reset the time to preset 2 and start the cycle over. (Output 2 will remain on until its time value has occurred.) Manual reset will turn off both outputs, if still turned on, and reset the time to Preset 2.



When used as an OFF/ON RECYCLING timer, the total cycle time is equal to the preset 2 value. The first lobe of the cycle will use output 1. The first ON delay is equal to the programmed timed output 1 value. †† The second lobe of the cycle will use output 2. The second ON delay is equal to the programmed timed output 2 value. †† When "RUN" is at a low level, time will decrement. Output 1 (first ON delay) will activate when preset 1 is reached, and output 2 (second ON delay) will activate when zero is reached. The unit will recycle at the beginning of timed output 2.

MODE 15 OUTPUT 1 TURN OFF AT ZERO, TIMED OUTPUT 2 AT ZERO, AUTOMATIC RESET TO PRESET 2 AFTER TIMED OUTPUT 2 † (INSTANTANEOUS & TWO LOBE OFF/ON RECYCLING, TIME DOWN)

In this mode, as the unit times down from preset 2, output 1 will turn on when preset 1 is reached. When zero is reached output 2 will turn on and output 1 will turn off. Output 2 will turn off after its programmed time value has occurred. At the end of Timed output 2, the unit will automatically Reset to Preset 2 and start the cycle over. This mode also has an input tracking feature (INSTANTANEOUS CONTACT) where if preset 1 is set to zero, output 1 will turn on when the input is activated, and off when the input is deactivated. (After zero is reached, Output 1 will turn off and stay off, regardless of the input condition, until a reset occurs.) Manual reset will turn off both outputs, if turned on, and reset the time to preset 2.



When used as an OFF/ON RECYCLING timer, the total cycle time is equal to the sum of the preset 2 value and the programmed timed output 2 value. The first lobe of the cycle will use output 1. The first ON delay value is equal to the difference between preset 1 and zero (this is because output 1 will turn off at zero). The second lobe of the cycle will use output 2. The second ON delay value is equal to the programmed timed output 2 value. †† When "RUN" is at a low level, time will decrement. Output 1 (first ON delay) will activate when preset 1 is reached, and output 2 (second ON delay) will activate when zero is reached (output 1 will deactivate when zero is reached). The unit will recycle at the end of timed output 2.

† - The timed output value must be less than the value required to time from the reset condition to the preset point. Otherwise, the output will appear to be latched on.

†† - The maximum ON delay is 99.99 seconds.

Note: Many other modes of operation, too numerous to mention here, are possible with the Libra Timer. These "extra" modes of operation are accomplished by tying inputs to outputs, by using power up reset functions, etc.

TIME RANGE VALUE

Time Range switch settings are shown to the right of the chart below. The time range number corresponds to a binary code represented by the DIP switch positions. When the switch is up, it is equivalent to a zero. When the switch is down, it is equivalent to a one. The time range switch settings can be easily observed from the front panel by using self-test. At the end of self-test (*the third set of switches shown*), the state of these time range switches are displayed. These time range values must not be changed during normal course of operation because of the possibility of erratic operation. A reset must be made after the desired range has been selected to lock it into the internal memory.

TIME RANGE	Duration	5	6	7	8
TIME RANGE ZERO	99.99 Seconds	↑	↑	↑	↑
TIME RANGE ONE	99.99 Minutes	↑	↑	↓	↑
TIME RANGE TWO	99.99 Hours	↑	↓	↑	↑
TIME RANGE FOUR	999.9 Seconds	↑	↓	↓	↑
TIME RANGE FIVE	999.9 Minutes	↑	↓	↓	↓
TIME RANGE SIX	999.9 Hours	↓	↑	↑	↑
TIME RANGE EIGHT	9999 Seconds	↓	↑	↓	↑
TIME RANGE NINE	9999 Minutes	↓	↑	↓	↓
TIME RANGE TEN	9999 Hours	↓	↓	↑	↑
TIME RANGE TWELVE	99 Minutes and 59 Seconds	↓	↓	↓	↑
TIME RANGE THIRTEEN	99 Hours and 59 Minutes	↓	↓	↓	↓

Note: TIME RANGES 3, 7, and 11 are not valid ranges.

CONNECTIONS

As depicted in the drawing showing the rear view of the Libra Timer, there are two terminal blocks where all wiring connections are made. The blocks can be removed for easy access to the terminal screws. To remove the block, pull from the back of the block until it slides clear of the terminal block shroud. **CAUTION:** The terminal blocks should **NOT** be removed with power applied to the unit.

All the DC power and input connections are made to the top terminal block labeled TBA. The AC power and output connections are made to the bottom terminal block labeled TBB. The input connections will be discussed first, using the drawing as a guide.

(The input connections are the same for 1 or 2 preset timers.)

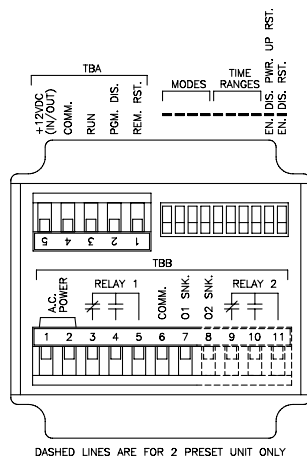

EMC INSTALLATION GUIDELINES

Although this unit is designed with a high degree of immunity to ElectroMagnetic Interference (EMI), proper installation and wiring methods must be followed to ensure compatibility in each application. The type of the electrical noise, source or coupling method into the unit may be different for various installations. It should be noted that the methods listed below may not be necessary for every unit installation. In extremely high EMI environments, additional measures may be needed. The unit becomes more immune to EMI with fewer I/O connections. Cable length, routing and shield termination are very important and can mean the difference between a successful installation or a troublesome installation. Listed below are some EMC guidelines for successful installation in an industrial environment.

- Use shielded (screened) cables for all Signal and Control inputs. The shield (screen) pigtail connection should be made as short as possible. The connection point for the shield depends somewhat upon the application. Listed below are the recommended methods of connecting the shield, in order of their effectiveness.
 - Connect the shield only at the panel where the unit is mounted to earth ground (protective earth).
 - Connect the shield to earth ground at both ends of the cable, usually when the noise source frequency is above 1 MHz.
 - Connect the shield to common of the unit and leave the other end of the shield unconnected and insulated from earth ground.

- Never run Signal or Control cables in the same conduit or raceway with AC power lines, conductors feeding motors, solenoids, SCR controls, and heaters, etc. The cables should be run in metal conduit that is properly grounded. This is especially useful in applications where cable runs are long and portable two-way radios are used in close proximity or if the installation is near a commercial radio transmitter.
- Signal or Control cables within an enclosure should be routed as far away as possible from contactors, control relays, transformers, and other noisy components.
- In extremely high EMI environments, the use of external EMI suppression devices, such as ferrite suppression cores, is effective. Install them on Signal and Control cables as close to the unit as possible. Loop the cable through the core several times or use multiple cores on each cable for additional protection. Install line filters on the power input cable to the unit to suppress power line interference. Install them near the power entry point of the enclosure. The following EMI suppression devices (or equivalent) are recommended:
 - Ferrite Suppression Cores for signal and control cables:
 - Fair-Rite # 0443167251 (RLC #FCOR0000)
 - TDK # ZCAT3035-1330A
 - Steward #28B2029-0A0
 - Line Filters for input power cables:
 - Schaffner # FN610-1/07 (RLC #LFIL0000)
 - Schaffner # FN670-1.8/07
 - Corcom #1VB3
 - Corcom #1VR3
- Note: Reference manufacturer's instructions when installing a line filter.
- Long cable runs are more susceptible to EMI pickup than short cable runs. Therefore, keep cable runs as short as possible.
- Switching of inductive loads produces high EMI. Use of snubbers across inductive loads suppresses EMI.
 - Snubbers:
 - RLC #SNUB0000

DC POWER AND INPUT CONNECTIONS

Terminal number 5 on TBA (*the first terminal from the left*), is the +12 VDC input/output terminal. As an output, this terminal is for sensor supply and can provide up to 150 mA of current. As an input, an external 11 to 14 VDC supply can be applied to this terminal to power the unit in the absence of AC power. Terminal 4 is the common terminal which the common line from the sensor and other inputs are connected. (*Do NOT connect relay common or solid-state output common to this point.*) Terminal 3 is the run terminal. When the signal at this terminal is pulled low (zero volts), time will accumulate on the display. Terminal 2 is the Program Disable (PGM. DIS.) terminal. When this terminal is at high level (+5 V), the Preset value (s) and timed output value(s) can be changed using the front panel buttons. (*Outputs can also be tested during self-test.* See "Self-Test" section for further details.) When terminal 2 is at a low level (connected to COMMON), changing these values and testing of the outputs is no longer possible. Terminal 1 is the Remote Reset terminal. When this terminal is at a low level (connected to COMMON), the unit will reset and, the outputs will turn off (if activated). As long as reset is low, the unit is held at reset.

Do not power up the unit with the Remote Reset terminal tied low and the Power Up Reset DIP switch enabled. This causes the display to lock. To restore the display, move the DIP switch to the disable position and cycle power.

AC POWER & OUTPUT CONNECTIONS

As mentioned before, AC power and output connections are made to the bottom terminal block, labeled TBB. Primary A.C. power is connected to terminal 1 and 2 (marked A.C. Power, located on the left-hand side of terminal block TBB). For best results, the A.C. Power should be relatively "clean" and within the specified $\pm 10\%$ variation limits. Drawing power from heavily loaded circuits or from circuits that also power loads that cycle on and off, should be avoided.

Terminals 3, 4, and 5 are used to connect to the output relay 1. Terminal 3 is the normally closed contact. Terminal 4 is the normally open contact, and Terminal 5 is the output relay common. Terminal 6 is an output common used for the solid-state output(s). This terminal should NOT be used as the common for the input or control terminals. Terminal 7 is the current sinking output 1 (labeled O1-SNK.). This internally connects to an NPN Open Collector transistor. The remaining terminals are for the dual preset version of the Libra timer and serve the same functions as those for the single preset unit. Terminal 8 is current sinking output 2 (labeled O2-SNK.). Terminal 9 is the normally closed contact of relay 2. Terminal 10 is the normally open contact. Terminal 11 is the output relay common.

FRONT PANEL FUNCTION DESCRIPTION

These units employ six front panel buttons for control and data entering. The button functions are described below.

RESET “R” - This button resets the counter to either zero or preset, depending on the mode of operation selected. For this button to operate, the enable/disable reset button switch, at the rear of the unit, must be set to the enable (EN) position. This button is also used in conjunction with the two preset buttons (*one button on the single preset unit*) to view and change the timed output value. (*When reset is activated, all processes are stopped or interrupted. I.E. outputs turn off, time stops, display is halted, etc.*) This is the case under any mode of operation, or any data entry mode.

PRESET “1” (“2”) - The preset buttons are labeled and are the two left-hand buttons of the top row, located on the front of the unit. (*For the single preset unit, the left-most button is the preset button.*) When the “1” button is pressed, preset 1 is displayed. When the “2” (*if available*) button is pressed, preset 2 is displayed. These values will remain displayed for approximately 10 sec. after release of the button. Also, the preset buttons are used in conjunction with the reset button, to view and change the timed output values. (*See “To Enter A New Timed Output Value” section.*)

ENTER “E” - This button is used in the “Preset Enter” mode and in the “Timed Output Enter” mode. After the desired value is obtained on the display, this button is pressed which then enters the value into the internal processor. This new value, at that instant, is used in the processing of preset or timed output values. “E” is also used at the end of self-test to exit self-test.

TO ENTER A NEW PRESET VALUE

FIRST: Press “1” (*or “2”, if a two preset unit*). This will display the respective preset value and it will remain displayed for approximately 10 sec. after release of the last button pushed. (*At this time, preset display mode can be exited without change, by pressing the “E” button.*)

SECOND: Once the preset value is displayed, changing the digit value can be done by pressing the button directly beneath the digit position to be changed. (*This value cannot be changed when “PGM. DIS.” is activated.*) Each time the button is pressed, the digit will increment by one. Also, pressing and holding the button will continuously scroll the digit from 0 through 9, then back to 0 again. When the desired value for that digit is reached, release the button. Do this for all the digits to be changed.

THIRD: Press the “E” (*Enter*) button to enter the value into the unit’s memory. As soon as the “E” button is pressed, this new value is used as the operating data. This means, if the preset value is entered, and the old or new value has not been reached, the new value will be used without process disruption (*Preset on the fly*). If the “E” button is not pressed within 10 sec. after the last digit has been changed, the value will disappear (*go back to normal display mode*) and the unit will continue to operate on the previous value. During the displaying, changing, and entering of a new preset value, all functions of the unit are operational, such as, timing, resetting, outputs firing, etc. *Note: For RTP modes of operation, “1” (“2” for dual preset units) will determine the “Start Count” value of each cycle.*

TO ENTER A NEW TIMED OUTPUT VALUE

FIRST: Press and hold the “1” (*or “2”, for two preset units*) button and then press the “R” (*Reset*) button. At this time, the respective timed output value will be displayed and will remain displayed for approximately 10 sec. after release of the last button pushed. (*At this time, the timed output display mode can be exited without change, by pressing the “E” button.*)

SECOND: Once the timed output is displayed, changing the digit value can be done by pressing the button directly beneath the digit position to be changed. (*This value cannot be changed when “PGM. DIS.” is activated.*) Each time the button is pressed, the digit will increment by one. Also, pressing and holding the button will continuously scroll the digit from 0 through 9, then back to 0 again. When the desired value for that digit is reached, release the button. Do this for all the digits to be changed. (*This value can be set between 0.01 sec and 99.99 sec.*)

THIRD: Press the “E” (*Enter*) button to enter the value into the unit’s memory. As soon as the “E” button is pressed, this new value is used as the operating data. If the “E” button is not pressed within 10 sec. after the last digit has been changed, the value will disappear (*go back to normal display mode*) and the unit will continue to operate on the previous value. During the displaying, changing, and entering of a new timed output value, all functions of the unit are active, such as timing, resetting, output firing, etc. without any interruption.

SELF-TEST

This unit has a built-in, self-test feature, which can be activated without losing time, preset values, missing preset points, timed output durations, or interfering with control functions. With this test, all digits are cycled through, then the mode select, the power up reset, and the time range switch settings are displayed (*in that order*). During the display of the mode select switch settings, the outputs can also be tested.

To enter self-test, press the two upper right-hand digit buttons (*located on the front panel*), simultaneously. At this time, whatever time value was displayed will disappear and be replaced by a string of four zeros. This will be shown for about half a second, then a string of ones will appear for the same time duration. Following these, a string of twos and so on, up to nine will be displayed. After the nines are shown, three decimal points will appear. After this portion, an interlace pattern of the same numbers will be shown. First, a combination of 1, 0, 1, 0 then 1, 2, 1, 2 and so on, until all digits from zero to nine have been displayed.

The next portion of self-test will display a group of ones and zeros. These ones and zeros are the settings of the mode select switches (*the four left-hand DIP switches only*). This pattern directly corresponds to the number representing the mode of operation. If the switches are changed while at this point in the self-test, the settings can be seen to change. These changes will not affect counter operation immediately, but any changes will take effect when self-test is exited. When the switch is “DOWN”, the display will show a one. When the switch is “UP”, the display will show a zero. If no testing of the outputs is required, press the “E” button until the unit advances to the next display (*the unit will next show the power-up reset DIP switch setting*). Also, if no activity occurs on the switches or the front panel buttons within 18 sec. after the unit pauses at the mode switch display, the unit will automatically advance to the next display.

During the time the mode switch settings are displayed, the outputs can be tested. To activate the outputs, press the “1” button (*for dual preset version, “1” or “2” is pressed*).

Note: The “PGM. DIS.” terminal must be at a high level for the outputs to be activated. Also, caution should be used when testing the outputs, so as not to cause any undesirable or hazardous conditions in the system. (To turn off the outputs, release the button.) If the outputs are not tested, the state of the outputs will remain the same as it was prior to self-test. If the outputs are tested in self-test, the outputs will be turned off after exiting self-test.

After the display of the mode switch settings, the state of the power-up reset DIP switch is shown. If the display shows a zero, then power-up reset is “DISABLED”. If the display shows a one, then power-up reset is “ENABLED” which means the unit will reset itself when input power is restored. As with the previous DIP switch settings, the unit will go on to the next display if no activity occurs on the switches or the front panel buttons within 18 seconds after entering the power-up reset display section. (*Pressing “E” will also cause the unit to advance to the next display.*)

The time range DIP switch settings are displayed next. This pattern directly corresponds to the number representing the time range value. If the switches are changed while at this point in self-test, the settings can be seen to change. These changes will not affect timer operation immediately, but any changes will take effect when self-test is exited. When the switch is “DOWN”, the display will show a one. When the switch is “UP”, the display will show a zero. Press the “E” button until the unit exits self-test (*The unit will go back to displaying the time*). Also, if no activity occurs on the switches or the front panel buttons within 18 seconds after the unit pauses at the time range switch display, the unit will automatically exit self-test.

Rapid advance of the self-test routine can be done by pressing and releasing any of the front panel buttons except for the “R” button. (*Pressing “R” at any time, except when entering the timed output mode, will reset the unit.*)

INITIAL POWER-UP & FACTORY SETTINGS

When the unit is shipped from the factory, the values and following modes are set as shown.

Preset 1	=	05.00
Preset 2	=	10.00 (<i>if a dual preset version</i>)
Time value	=	0.00
Timed output values	=	00.10 second

DIP SWITCH SETTINGS

All switches are moved up to the “UP” position except for the front panel reset enable switch, which is moved “DOWN”. With the switches set in these positions, the unit is operating in mode zero (*latch preset(s), manual reset to zero, time stops at preset 2*). The time range value is 99.99 seconds and the power-up reset is disabled.

INSTALLATION

The Libra counters and timers are designed to be panel-mounted with a gasket to provide a water-tight seal. Two mounting clips and screws are provided for easy installation. Consideration should be given to the thickness of the panel. Too thin of a panel may distort and not provide a water-tight seal. (Recommended minimum panel thickness is 1/8".)

After the panel cut-out has been completed and deburred, carefully apply the gasket to the panel. **DO NOT APPLY THE ADHESIVE SIDE OF THE GASKET TO THE COUNTER BEZEL.** Insert the unit into the panel. As depicted in the drawing (at right), install the screws into the narrow end of the mounting clips. Thread the screws into the clips until the pointed end just protrudes through the other side. Install each of the two mounting clips by inserting the wide lip of the clips into the front end of the hole, located on either side of the case. Then snap the clip onto the case. Tighten the screws evenly to apply uniform compression, thus providing a water-tight seal.

Caution: Only minimum pressure is required to seal panel. Do **NOT** over-tighten mounting screws.

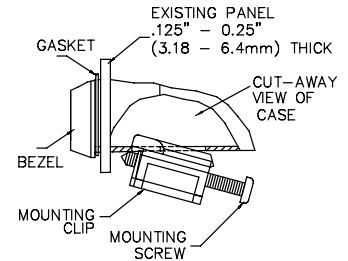
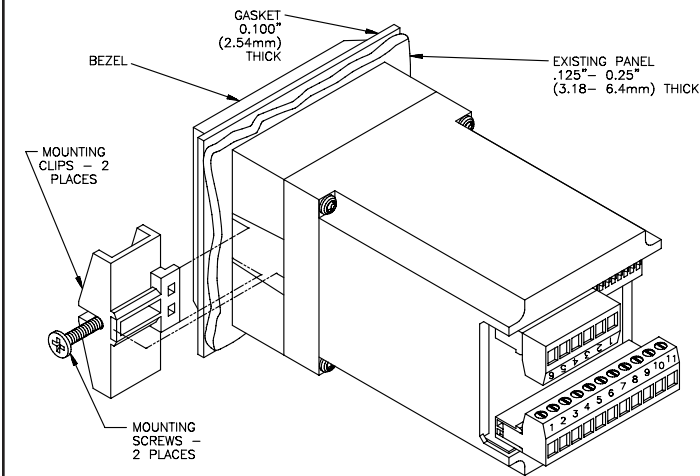

APPLICATION FOR DUAL LEVEL PRESET LIBRA TIMER

CURING/DRYING PROCESS CONTROL

In a typical manufacturing curing/drying process, it is required to control the duration of time heat is applied to the items within an oven. These items are to be heated at a high temperature for a long period of time (30 minutes). At the end of the curing/drying process, the heat is turned off and an indicator light is turned on, signaling the unloading attendant. The dual preset Libra timer will satisfy all these requirements.

The Libra timer is first set to minutes time range, which is time range 9. Next, the mode switches are set to Mode 0 (Latch Outputs at Presets, Manual Reset to Zero, Time Stops at Preset 2). Mode 0 is used because the outputs must latch on when the presets are reached (When the outputs latch on, the heaters de-energize). Also, the time increments will stop at preset 2. The power-up reset switch is set to "Enable", which causes the unit to start the cycle over in the event of an input power loss (when enabled, the unit will reset itself when input power is restored). The front panel reset button "EN./DIS." switch is "Disabled" to prevent accidental resetting (restarting) of the cycle. The "REM. RST." terminal is connected to a remote reset button located at the loading end of the oven. The "PGM. DIS." and the "RUN" terminals are tied to the "COMMON" terminal. With "PGM. DIS." tied low (this is done after preset 1 is set to 3 minutes and preset 2 is set to 33 minutes), the heating time periods cannot be changed. "RUN" is permanently tied low, which causes the unit to increment time (when Preset 2 is reached, Mode 0 will cause time accumulation to stop). The normally closed contact of Relay 1 is connected to the high temperature heater and the normally closed contact of Relay 2 is connected to the low temperature heater. The operation sequence is as follows:

The operator/attendant wheels a rack of items into the heating area (oven). Once the oven doors are closed, the operator/attendant presses the remote reset switch which starts the heating cycle (both high and low temperature heaters are turned on at this time). After three minutes have elapsed, output 1 fires, which opens the normally closed contact of Relay 1. (This turns off the high temperature heater.) After 30 minutes have elapsed, output 2 fires, which stops the time accumulation and opens the normally closed contact of Relay 2. (This turns off the low temperature heater.) Also, the normally open contact of Relay 2 closes, which then turns on the indicator light. (This signals the unloading attendant that the process is complete.)

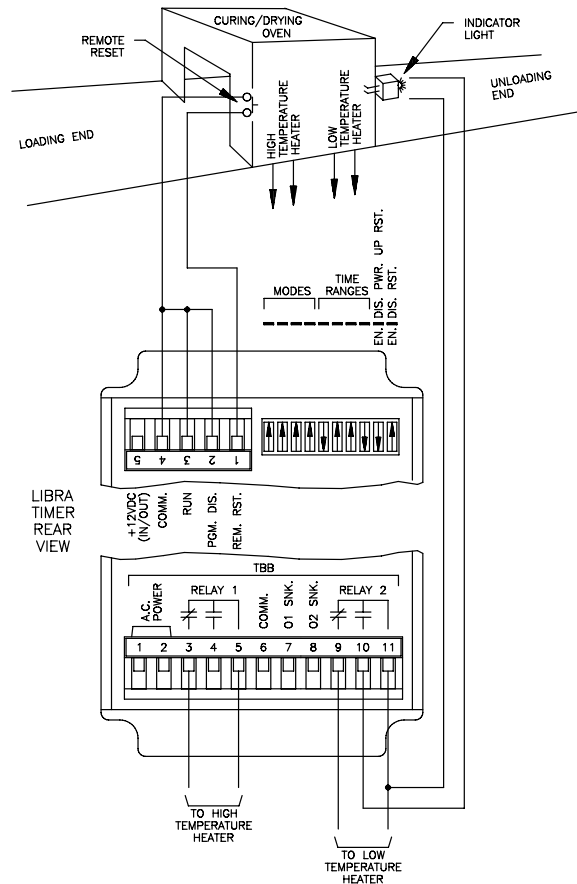

ORDERING INFORMATION

MODEL NO.	DESCRIPTION	PART NUMBERS FOR AVAILABLE SUPPLY VOLTAGES	
		230 VAC	115 VAC
LIBT1	Single Preset LCD Libra Timer	LIBT1010	LIBT1000
LIBT2	Dual Preset LCD Libra Timer	LIBT2010	LIBT2000
LIBT1E	Single Preset LED Libra Timer	LIBT1E10	LIBT1E00
LIBT2E	Dual Preset LED Libra Timer	LIBT2E10	LIBT2E00

For more information on Pricing, Enclosures & Panel Mount Kits refer to the RLC Catalog or contact your local RLC distributor.