

THIS IS A C.A.D. GENERATED DRAWING
DO NOT MAKE MANUAL REVISIONS TO MASTER.

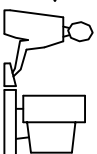

ISSUE NUMBER
ORIGINAL

①

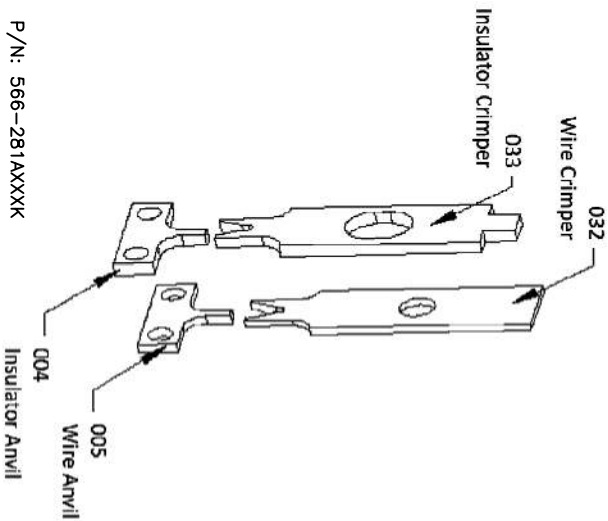
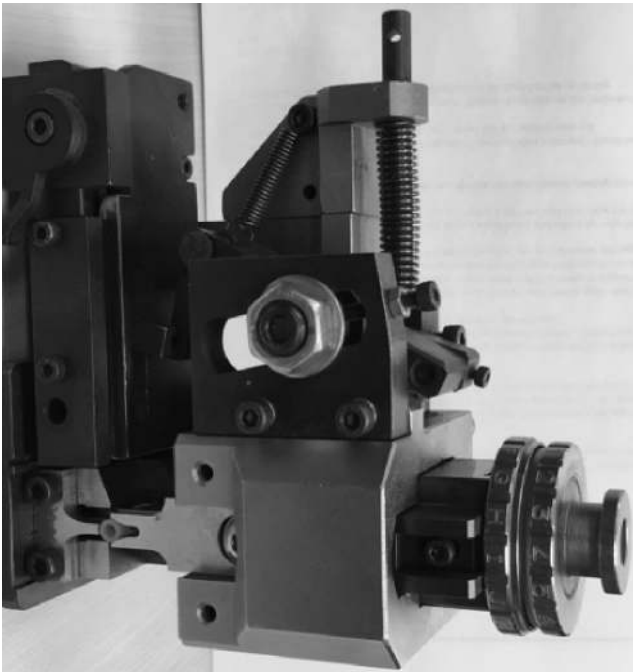

P/N: 566-281AXXXK

PRESS TYPE	K PRESS
STROKE LENGTH	30.00 MM
SHUT HEIGHT	119.55 MM
AWG	20-28

REPLACEMENT PUNCH & DIE PARTS			
INSULATOR ANVIL	WIRE ANVIL	WIRE CRIMPER	INSULATOR CRIMPER
566-281A004K	566-281A005K	566-281A032K	566-281A033K

NOTES:

- 1- THIS APPLICATOR IS DESIGNED TO BE USED ON A K CRIMPING MACHINE.
- 2- THIS APPLICATOR IS DESIGNED FOR CRIMPING EDAC CONTACT P/N 566-290-711.
- 3- FOR THE DEFINITION OF STROKE LENGTH AND SHUT HEIGHT, APPLICATOR SETUP AND OPERATING INSTRUCTION, PLEASE REFER TO DOCUMENT "APPLICATOR INSTRUCTION MANUAL K PRESS".

K PRESS APPLICATOR FOR 566-290-711

ACAD REFERENCE NO. 566-280-751K

DRAWN: K.L. DATE: OCT.29/2020

CHECKED: R.S.M. DATE: OCT.29/2020

SCALE: N.T.S. SHEET 1 OF 1

DRAWING NUMBER

566-280-751K

ISSUE
1

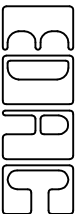

EDAC INC
TORONTO, ONTARIO
CANADA

YOUR CONNECTION TO QUALITY & SERVICE

THESE DRAWINGS AND SPECIFICATIONS ARE THE PROPERTY OF EDAC INC. AND SHALL NOT BE REPRODUCED, OR COPIED OR USED AS THE BASIS FOR THE MANUFACTURE OR SALE OF APPARATUS WITHOUT WRITTEN PERMISSION.