

Features

- AEC-Q200 qualified
- Meets IEC 61000-4-2 standard
- Multilayered varistor technology
- Proprietary insulating overcoat provides low and stable leakage current
- Quick response time (<0.5 ns)
- High transient current capability
- High reliability
- RoHS compliant*

Applications

- HDMI
- CANbus
- Ethernet
- GPS
- Camera links
- Sensors
- Touchscreen interfaces
- Circuits sensitive to ESD

ChipGuard® Automotive MLA Series Varistor ESD Clamp Protectors

Description

Bourns® ChipGuard® Automotive MLA Series is a multilayered varistor designed specifically for use in automotive circuits requiring ESD protection. The CGA-MLA series is available in industry standard 0603, 0805 and 1206 packages. These robust protectors exhibit extremely fast response times to ESD events making them ideal for protecting a wide array automotive electronics.

ChipGuard® Automotive MLA Series products are fully AEC-Q200 qualified and supported.

Device Symbol

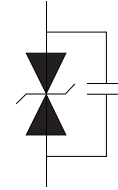

Electrical Characteristics @ 25 °C (unless otherwise noted)

Model	Package	Vrms	VDC	VN Min.	VN Max.	VC	ITM (Max.)	WTM (Max.)	CP
		(V)	(V)	(V)	(V)	(V)	(A)	(J)	(pF) Typ.
		<10 μA	1 mA DC		1 A @ 8/20 μs	@ 8/20 μs	10/1000 μs	@ 1 KHz	
CGA0603MLA-16150E	0603	14	16	23.0	34.2	70	5	0.030	15
CGA0603MLA-16121E		14	16	22.0	28.0	46	30	0.200	120
CGA0603MLA-17300E		14	17	21.6	34.4	70	2	0.050	30
CGA0603MLA-18101E		14	18	19.8	25.2	44	30	0.200	100
CGA0603MLA-19161E		14	19	24.0	32.0	64	20	0.100	160
CGA0603MLA-22750E		17	22	25.0	41.0	54	30	0.075	75
CGA0603MLA-22500E		17	22	24.3	30.7	54	10	0.100	50
CGA0603MLA-22101E		17	22	24.3	30.7	50	30	0.200	100
CGA0603MLA-22161E		17	22	24.3	30.7	50	30	0.200	160
CGA0603MLA-26800E		20	26	30.0	43.0	67	30	0.100	80
CGA0603MLA-31900E		25	31	35.0	43.9	71	30	0.200	90
CGA0603MLA-32120E		25	32	51.9	71.0	124	5	0.250	12
CGA0805MLA--16401E		0805	14	16	22.0	28.0	46	120	0.3
CGA0805MLA-18351E	14		18	19.8	25.2	44	120	0.3	350
CGA0805MLA-22101E	17		22	25.0	34.0	54	30	0.1	100
CGA0805MLA-22401E	17		22	24.3	30.7	50	120	0.3	400
CGA0805MLA-26221E	20		26	29.7	37.3	56	80	0.4	220
CGA0805MLA-31251E	25		31	35.1	43.9	71	80	0.3	250
CGA0805MLA-38201E	30		38	42.3	52.7	81	80	0.3	200
CGA1206MLA-16801E	1206	14	16	22.0	28.0	44	200	0.60	800
CGA1206MLA-16701E		14	16	19.8	25.2	42	200	0.50	700
CGA1206MLA-22651E		17	22	24.3	30.7	48	200	0.30	650
CGA1206MLA-22841E		17	22	24.3	29.7	50	100	0.40	840
CGA1206MLA-26601E		20	26	29.7	37.3	58	200	0.70	600
CGA1206MLA-31551E		25	31	35.1	43.9	69	200	1.00	550
CGA1206MLA-38501E		30	38	42.3	52.7	81	200	1.10	500
CGA1206MLA-40181E		40	56	63.0	77.0	110	200	1.00	180

General Characteristics

Operating Temperature.....	-55 °C to +125 °C
Storage Temperature.....	-55 °C to +150 °C
Response Time.....	<1 ns
Performance Standard	IEC 61000-4-2

*RoHS Directive 2002/95/EC Jan. 27, 2003 including annex and RoHS Recast 2011/65/EU June 8, 2011.

Specifications are subject to change without notice.

The device characteristics and parameters in this data sheet can and do vary in different applications and actual device performance may vary over time. Users should verify actual device performance in their specific applications.

Product Dimensions

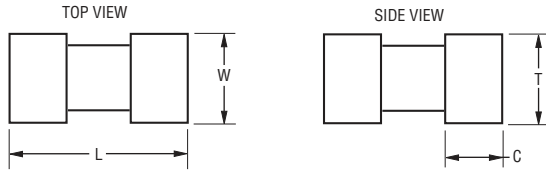

DIMENSIONS: $\frac{\text{MM}}{\text{(INCHES)}}$

Dim.	CGA0603MLA Series	CGA0805MLA Series	CGA1206MLA Series
L	$\frac{1.60 \pm 0.15}{(0.063 \pm 0.006)}$	$\frac{2.00 \pm 0.20}{(0.079 \pm 0.008)}$	$\frac{3.20 \pm 0.30}{(0.126 \pm 0.012)}$
W	$\frac{0.80 \pm 0.10}{(0.031 \pm 0.004)}$	$\frac{1.25 \pm 0.20}{(0.049 \pm 0.008)}$	$\frac{1.60 \pm 0.20}{(0.063 \pm 0.008)}$
T	$\frac{0.80 \pm 0.10}{(0.031 \pm 0.004)}$	$\frac{0.90 \pm 0.10}{(0.035 \pm 0.004)}$	$\frac{1.70}{(0.067)}$ MAX.
C	$\frac{0.30 \pm 0.15}{(0.012 \pm 0.006)}$	$\frac{0.50 \pm 0.25}{(0.020 \pm 0.010)}$	$\frac{0.50 \pm 0.25}{(0.020 \pm 0.010)}$

Construction

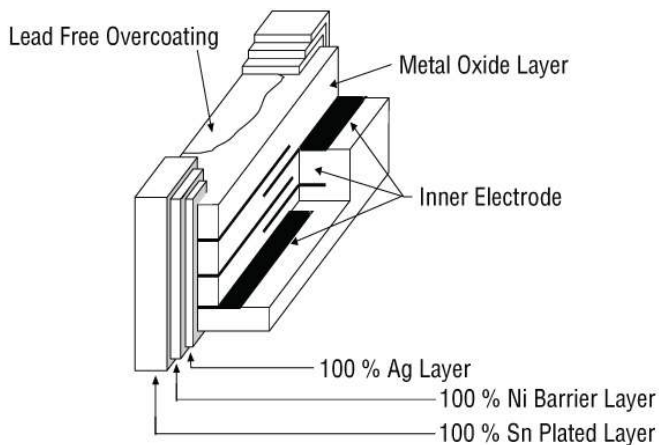

Recommended Pad Layout

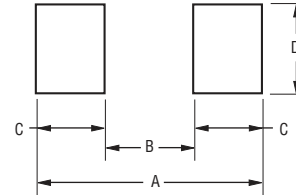

Note: Print solder to a recommended thickness of 150 to 200 μm .

Dim.	CGA0603MLA Series	CGA0805MLA Series	CGA1206MLA Series
A	$\frac{2.54}{(0.100)}$	$\frac{3.50}{(0.137)}$	$\frac{4.06}{(0.160)}$
B	$\frac{0.50}{(0.020)}$	$\frac{1.10}{(0.043)}$	$\frac{2.02}{(0.080)}$
C	$\frac{1.02}{(0.040)}$	$\frac{1.20}{(0.047)}$	$\frac{1.02}{(0.040)}$
D	$\frac{0.76}{(0.030)}$	$\frac{1.20}{(0.047)}$	$\frac{1.65}{(0.065)}$

How to Order

CG A xx0x MLA - xx yyy E

ChipGuard® Product Designator _____

Automotive Series _____

Package Option _____
 0603 = 1608 Package
 0805 = 2012 Package
 1206 = 3216 Package

Multilayer Series Designator _____

Maximum DC Working Voltage, V _____
 (Current <10 μA)

Capacitance, pF _____
 (Example: 151 = 15x10¹ (150 pF))

Tape & Reel Packaging _____
 E = 4,000 pcs. per reel

Solder Reflow Recommendations

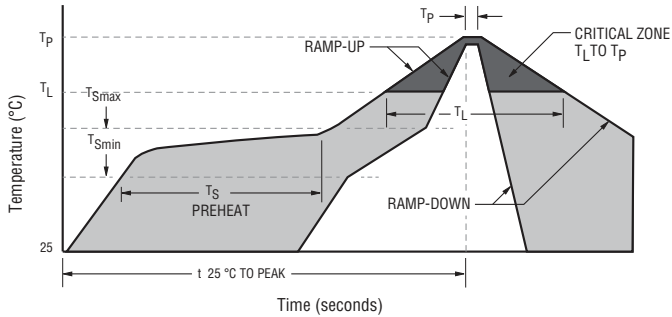

A	Stage 1 Preheat Ramp	Ambient to Preheating Temperature	3 °C / s max.
B	Stage 2 Preheat	Preheat min./max. Temperature Range	150 °C to 200 °C 60 s to 180 s
C	Stage 3 Preheat to Main Heating	Max. Time Above Stated Temperature	217 °C 60 s to 150 s
D	Main Heating	Max. Time Within 5 °C of Peak Temperature (260 °C)	255 °C 20 s to 40 s
E	Cool Down	Rate from Peak Temperature	6 °C / s max.

CAUTION:

- Rapid heating and cooling in excess of stated maximum rates will easily damage this product.
- Localized heating can also damage product.
- Do not thermally shock product in excess of 100 °C.
- Use a 30 W or less solder gun/iron for product repairs. Tip temperature maximum is 280 °C for less than 3 seconds.
- Do not touch the component directly with the soldering gun/iron.
- Excess solder volumes can damage the body of the product.

Packaging Dimensions

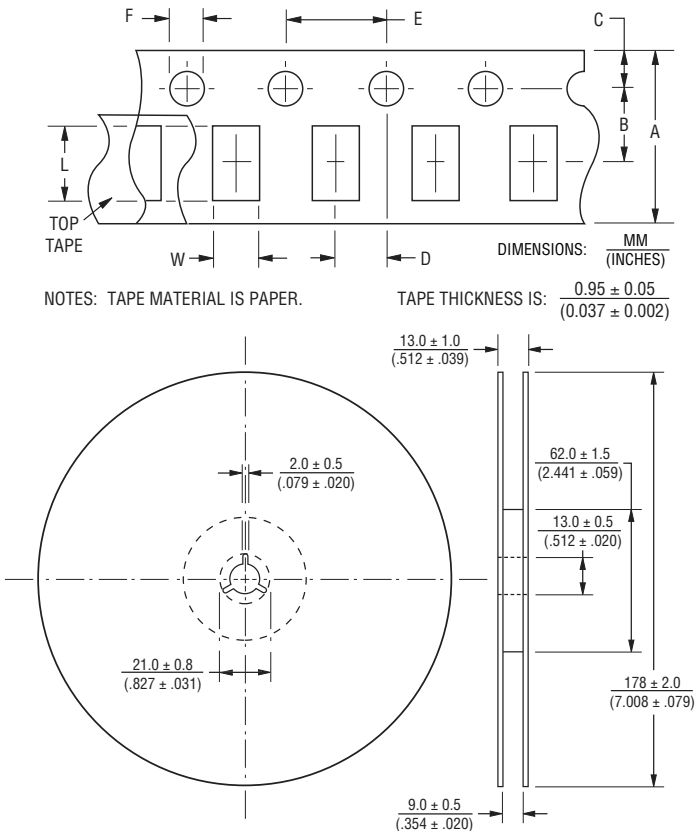

Dim.	CGA0603MLA Series	CGA0805MLA Series	CGA1206MLA Series
A	$\frac{8.00 \pm 0.30}{(0.315 \pm 0.012)}$		
B	$\frac{3.50 \pm 0.05}{(0.138 \pm 0.002)}$		
C	$\frac{1.75 \pm 0.10}{(0.069 \pm 0.004)}$		
D	$\frac{2.00 \pm 0.05}{(0.079 \pm 0.002)}$		
E	$\frac{4.00 \pm 0.10}{(0.157 \pm 0.004)}$		
F	$\frac{1.50 \pm 0.10}{(0.059 \pm 0.004)}$		
L	$\frac{1.90 \pm 0.15}{(0.075 \pm 0.006)}$	$\frac{2.30 \pm 0.15}{(0.091 \pm 0.006)}$	$\frac{3.50 \pm 0.15}{(0.138 \pm 0.006)}$
W	$\frac{1.05 \pm 0.15}{(0.041 \pm 0.006)}$	$\frac{1.55 \pm 0.15}{(0.061 \pm 0.006)}$	$\frac{1.90 \pm 0.15}{(0.075 \pm 0.006)}$