

THIS DRAWING IS UNPUBLISHED. RELEASED FOR PUBLICATION, 19 .
 © COPYRIGHT 19 BY AMP INCORPORATED. ALL INTERNATIONAL RIGHTS RESERVED.

LOC G	DIST 14	P	F	REVISIONS			DATE	APPD
				ZONE	LTR	DESCRIPTION		
					AB	REV PER OG3A-0198-99	270CT99	JR/TM

AMP WIRE RANGE	UL E13288 Listed	SR LR7189 Certified
16-14 AWG SOLID OR STRANDED	16-14 AWG SOLID OR STRANDED	16-14 AWG SOLID OR STRANDED

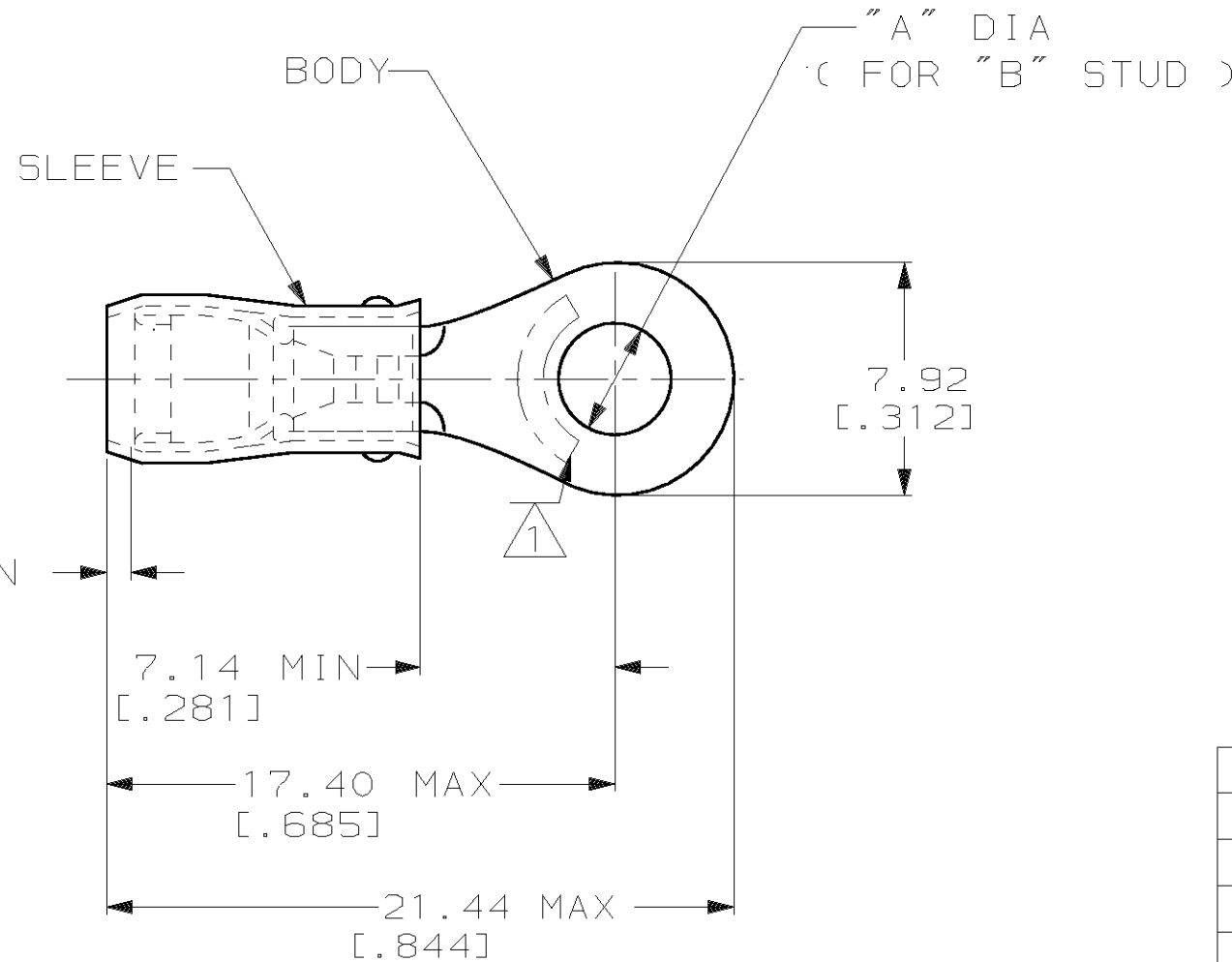

- 1 STAMP AMP 16-14* APPROX AS SHOWN
- 2 WIRE INSULATION DIA: 2.67-3.81 [.105-.150]
- 3 TONGUE MATERIAL THK: 0.79±0.05 [.031±.002]

MILITARY P/N AND CLASS	"B"	DIM "A"	QUANTITY	PACKAGE TYPE	PART NO
-	10	5.00±0.08 [.197±.003]	100	LOOSE PIECE, BOX	5-51864-1
-	8	4.34±0.08 [.171±.003]	100	LOOSE PIECE, BOX	4-51864-1
-	6	3.68±0.08 [.145±.003]	100	LOOSE PIECE, BOX	3-51864-1
MS25036-153 CLASS 2	8	4.34±0.08 [.171±.003]	5000	ON TAPE, REEL	51864-5
MS25036-108 CLASS 2	10	5.00±0.08 [.197±.003]	5000	ON TAPE, REEL	51864-4
MS25036-107 CLASS 2	6	3.68±0.08 [.145±.003]	5000	ON TAPE, REEL	51864-3
MS25036-108 CLASS 1 & 2	10	5.00±0.08 [.197±.003]	1000	LOOSE PIECE	51864-2
MS25036-153 CLASS 1 & 2	8	4.34±0.08 [.171±.003]	1000	LOOSE PIECE	51864-1
MS25036-107 CLASS 1 & 2	6	3.68±0.08 [.145±.003]	1000	LOOSE PIECE	51864

AMP INCORPORATED
CUSTOMER SERVICE SYSTEMS

FOR ADDITIONAL PRODUCT INFORMATION OR COPIES OF DRAWINGS AND TECHNICAL DOCUMENTS
 PRODUCT INFORMATION CENTER
 1-800-522-6752

FOR APPLICATION TOOLING INFORMATION
 TOOLING ASSISTANCE CENTER
 1-800-722-1111

FOR ORDER ENTRY
 1-800-526-5142

MAX RECOMMENDED OPERATING TEMPERATURE:
 105°C MAX

VOLTAGE RATING:
 300 V MAX

CIRCULAR MIL AREA:
 1.04-2.62mm² [2050-5180] CIR MILS
 SOLID OR STRANDED

THIS DRAWING IS A CONTROLLED DOCUMENT FOR AMP INCORPORATED. IT IS SUBJECT TO CHANGE AND THE CONTROLLING ENGINEERING ORGANIZATION SHOULD BE CONTACTED FOR THE LATEST REVISION.

DO NOT SCALE PRINT. UNLESS SPECIFIED DIMENSIONS IN mm [INCHES] TOLERANCES ON:
 2 PLC DEC ± 0.20[.008]
 3 PLC DEC ± -
 ANGLES ± -

MATERIAL
 COPPER PER ASTM B-152 SLEEVE, BLUE NYLON

FINISH
 TIN PLATE PER ASTM B545

DR 270CT99
 JR RUTH
 CHK 270CT99
 RE HERSEY
 APPD 270CT99
 C PRESNELL
 APPD 270CT99
 T MICHELUTTI
 PRODUCT SPEC
 UL 486A
 APPLICATION SPEC
 NOT AVAILABLE
 WEIGHT -

AMP AMP Incorporated
 Harrisburg, PA 17105-3608

NAME
 TERMINAL, RING TONGUE, PIDG™,
 WIRE SIZE, 16-14 AWG

SIZE **B** CAGE CODE 00779 DRAWING NO **C-51864**

SCALE NTS SHEET 1 OF 2

THIS DRAWING IS UNPUBLISHED. RELEASED FOR PUBLICATION, 19 .
 © COPYRIGHT 19 BY AMP INCORPORATED. ALL INTERNATIONAL RIGHTS RESERVED.

LOC G	DIST 14	P	F	REVISIONS			DATE	APPD
				ZONE	LTR	DESCRIPTION		
					AB	REV PER OG3A-0198-99	260CT99	JR/TM

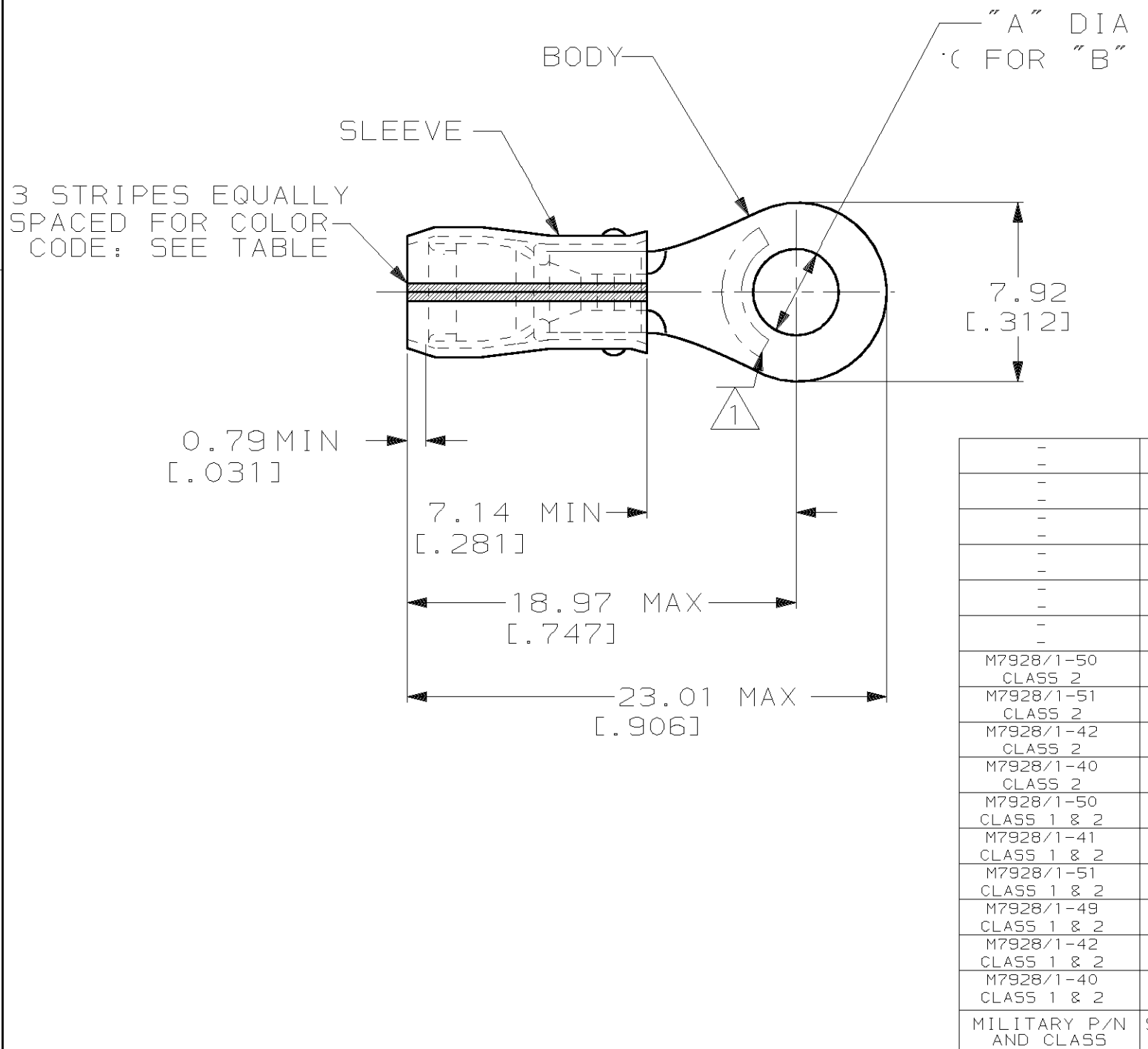

- 1 STAMP AMP [] APPROX AS SHOWN SEE TABLE BELOW
- 2 WIRE INSULATION DIA: 1.60-3.30 FOR 16 AWG [.063-.130]
1.98-3.30 FOR 14 AWG [.078-.130]
- 3 TONGUE MATERIAL THK: 0.79±0.05 [.031±.002]

AMP
WIRE RANGE

SEE TABLE
STRANDED

MILITARY P/N AND CLASS	STRIPE COLOR	WIRE SIZE	"B"	DIM "A"	QUANTITY	PACKAGE TYPE	PART NO	
-	GREEN	14*	14	8	4.34±0.08 [.171±.003]	100	LOOSE PIECE, BOX	9-51864-5
-	BLUE	16*	16	8	4.34±0.08 [.171±.003]	100	LOOSE PIECE, BOX	9-51864-3
-	GREEN	14*	14	10	5.00±0.08 [.197±.003]	100	LOOSE PIECE, BOX	9-51864-1
-	GREEN	14*	14	6	3.68±0.08 [.145±.003]	100	LOOSE PIECE, BOX	8-51864-1
-	BLUE	16*	16	10	5.00±0.08 [.197±.003]	100	LOOSE PIECE, BOX	7-51864-1
-	BLUE	16*	16	6	3.68±0.08 [.145±.003]	100	LOOSE PIECE, BOX	6-51864-1
M7928/1-50 CLASS 2	GREEN	14*	14	8	4.34±0.08 [.171±.003]	5000	ON TAPE, REEL	1-51864-7
M7928/1-51 CLASS 2	GREEN	14*	14	10	5.00±0.08 [.197±.003]	5000	ON TAPE, REEL	1-51864-5
M7928/1-42 CLASS 2	BLUE	16*	16	10	5.00±0.08 [.197±.003]	5000	ON TAPE, REEL	1-51864-3
M7928/1-40 CLASS 2	BLUE	16*	16	6	3.68±0.08 [.145±.003]	5000	ON TAPE, REEL	1-51864-2
M7928/1-50 CLASS 1 & 2	GREEN	14*	14	8	4.34±0.08 [.171±.003]	1000	LOOSE PIECE	1-51864-1
M7928/1-41 CLASS 1 & 2	BLUE	16*	16	8	4.34±0.08 [.171±.003]	1000	LOOSE PIECE	1-51864-0
M7928/1-51 CLASS 1 & 2	GREEN	14*	14	10	5.00±0.08 [.197±.003]	1000	LOOSE PIECE	51864-9
M7928/1-49 CLASS 1 & 2	GREEN	14*	14	6	3.68±0.08 [.145±.003]	1000	LOOSE PIECE	51864-8
M7928/1-42 CLASS 1 & 2	BLUE	16*	16	10	5.00±0.08 [.197±.003]	1000	LOOSE PIECE	51864-7
M7928/1-40 CLASS 1 & 2	BLUE	16*	16	6	3.68±0.08 [.145±.003]	1000	LOOSE PIECE	51864-6

AMP INCORPORATED
CUSTOMER SERVICE SYSTEMS

FOR ADDITIONAL PRODUCT INFORMATION OR COPIES OF DRAWINGS AND TECHNICAL DOCUMENTS: PRODUCT INFORMATION CENTER 1-800-522-6752

FOR APPLICATION: TOOLING ASSISTANCE CENTER 1-800-722-1111

TOOLING INFORMATION: 1-800-722-1111

FOR ORDER ENTRY: 1-800-526-5142

MAX RECOMMENDED OPERATING TEMPERATURE: 105°C MAX

VOLTAGE RATING: 300 V MAX

WIRE RANGE: 16 CIRC MIL AREA: 1.42mm² [2800]
14 2.15mm² [4234]

STRANDED

THIS DRAWING IS A CONTROLLED DOCUMENT FOR AMP INCORPORATED. IT IS SUBJECT TO CHANGE AND THE CONTROLLING ENGINEERING ORGANIZATION SHOULD BE CONTACTED FOR THE LATEST REVISION.

DO NOT SCALE PRINT. UNLESS SPECIFIED DIMENSIONS IN mm [INCHES] TOLERANCES ON:
 2 PLC DEC ± 0.20[.008]
 3 PLC DEC ± -
 ANGLES ± -

MATERIAL: COPPER PER ASTM B-152 SLEEVE, BLUE NYLON

FINISH: TIN PLATE PER ASTM B545

DR 260CT99 JR RUTH
 CHK 260CT99 RE HERSEY
 APPD 260CT99 C PRESNELL
 APPD 260CT99 T MICHELUTTI
 PRODUCT SPEC -
 APPLICATION SPEC NOT AVAILABLE
 WEIGHT -

AMP AMP Incorporated
Harrisburg, PA 17105-3608

NAME: TERMINAL, RING TONGUE, I.R., PIDG™, WIRE SIZE, 16-14 AWG

SIZE: B CAGE CODE: 00779 DRAWING NO: C-51864

SCALE: NTS SHEET: 2 OF 2