

### Ambient Light Sensor – Surface Mount EAALSTIC2012A0



#### Features

- Close responsively to the human eye spectrum
- Light to Current, analog output
- Good output linearity across wide illumination range
- Low sensitivity variation across various light sources
- Guaranteed temperature performance, -40°C to 85°C
- Wide supply voltage range, 2.5V to 5.5V
- Size : 2.0mm(L)\*1.25mm(W)\*0.8mm(H)
- RoHS compliant and Pb Free package
- Compliance with EU REACH.

#### Description

The EAALSTIC2012A0 is a low cost ambient light sensor, consisting of phototransistor in miniature SMD. Everlight Americas ALS series products are a good effective solution to the power saving of display backlighting of mobile appliances, such as the mobile phones, NB and PDAs. Due to the high rejection ratio of infrared radiation, the spectral response of the ambient light sensor is close to that of human eyes.

#### Applications

- Detection of ambient light to control display backlighting
  - Mobile devices – mobile phones, PDAs
  - Computing device – TFT LCD monitor for Notebook computer
  - Consumer device – TFT LCD TV, plasma TV, video camera, digital camera, toys
- Automatic residential and commercial management
- Automatic contrast enhancement for electronic signboard
- Ambient light monitoring device for daylight and artificial light
  - Street light, CCD/CCTV

**Packaging dimension**

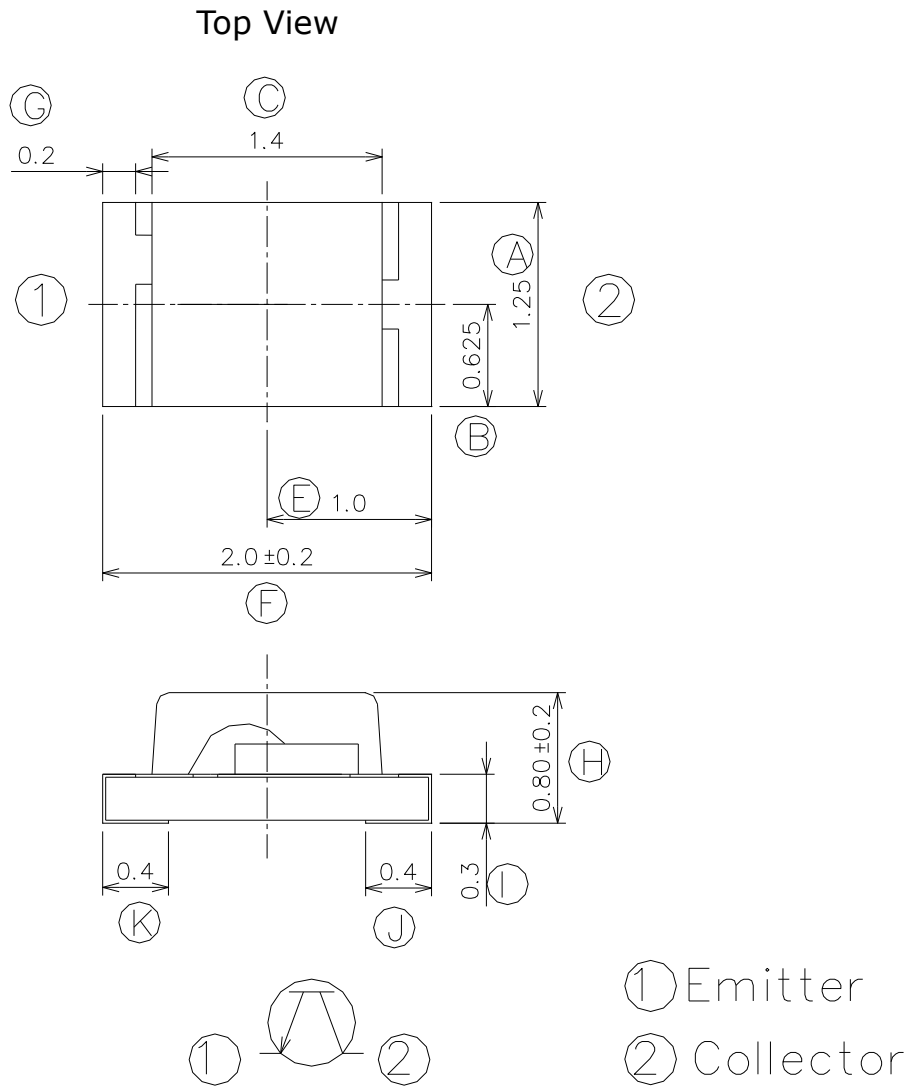

Note: Tolerances unless mentioned  $\pm 0.1$  mm. Unit = mm

### Absolute Maximum Ratings (Ta=25°C)

Parameter	Symbol	Rating	Unit
Supply Voltage	V <sub>CC</sub>	-0.5 ~ 6	V
Operating Temperature	T <sub>opr</sub>	-40 ~ +85	°C
Storage Temperature	T <sub>stg</sub>	-40 ~ +100	°C
Soldering Temperature	T <sub>sol</sub>	260 ± 10	°C

Note: For detail reflow time and the recommended temperature profile, please refer to page 8.

### Recommended Operating Conditions (Ta=25°C)

Parameter	Symbol	Min.	Max.	Unit
Supply Voltage	V <sub>CC</sub>	-40	+85	°C
Operating Temperature	T <sub>opr</sub>	2.5	5.5	V

### Rankings

Bin	Symbol	Min.	Max.	Unit	Test Condition
1	I <sub>PH(ON)</sub>	4	6.8	μA	VCE=5V EV=100Lux
2		5.9	8.8		
3		8	11		

### Electro-Optical Characteristics (Ta=25°C)

Parameter	Symbol	Min.	Typ.	Max.	Unit	Condition	
Dark Current	$I_{CEO}$	-----	-----	0.1	$\mu A$	$V_{CE}=10V,$ $E_V=0Lux$	
Collector-Emitter Saturation Voltage	$V_{CE(sat)}$	-----	-----	0.4	V	$I_C=2mA,$ $E_V=1000Lux$	
Light Current	$I_{PH1}$	4	7.5	11	$\mu A$	$V_{CE}=5V,$ $E_V=100Lux$ [Note1]	
	$I_{PH2}$	90	75	110	$\mu A$	$V_{CE}=5V,$ $E_V=1000Lux$ [Note1]	
	$I_{PH3}$	192	360	528	$\mu A$	$V_{CE}=5V,$ $E_V=1000Lux$ [Note2]	
Photocurrent Ratio	$I_{PH3}/I_{PH2}$	-----	4.8	-----	-----	$V_{CE}=5V,$ $E_V=1000Lux$	
Saturation Output Voltage	$V_O$	4.5	4.6	-----	V	$V_{CC}=5V,$ $E_V=1000Lx$ $R_L=75K$ [Note2]	
Peak Sensitivity Wavelength	$\lambda_P$	-----	630	-----	nm		
Sensitivity Wavelength Range	$\lambda$	390	-----	700	nm		
Switching Time	Rise Time	$t_r$	-----	0.11	-----	mS	$V_{CC}=5V,$ $R_L=7.5K\Omega$
	Fall Time	$t_f$	-----	0.22	-----	mS	

Note:

1. White Fluorescent light (Color Temperature = 6500K) is used as light source. However, White LED is substituted in mass production.
2. Illuminance by CIE standard illuminant-A / 2856K, incandescent lamp.

**Typical Electro-Optical Characteristics Curves**

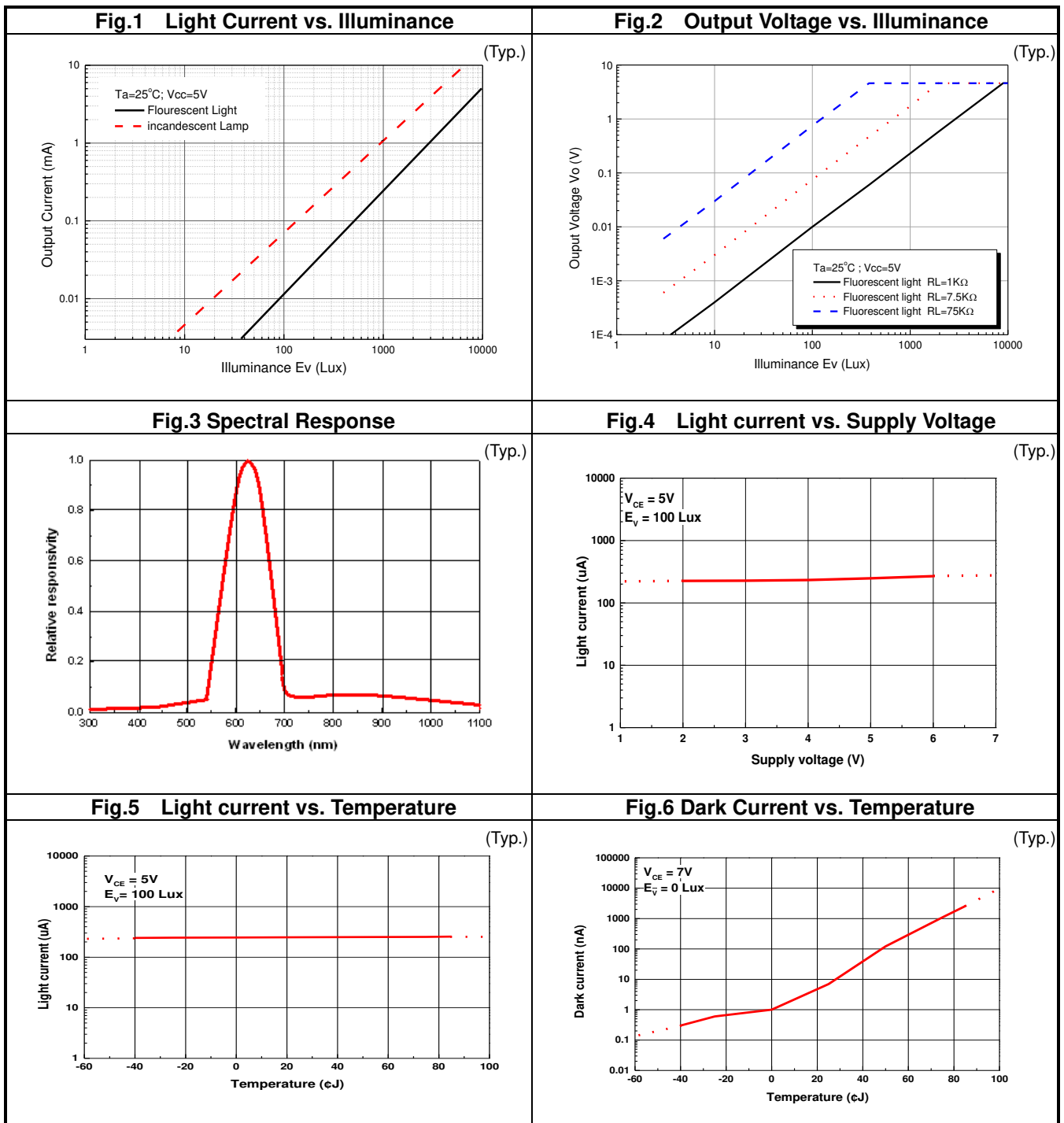

## Converting Photocurrent to Voltage

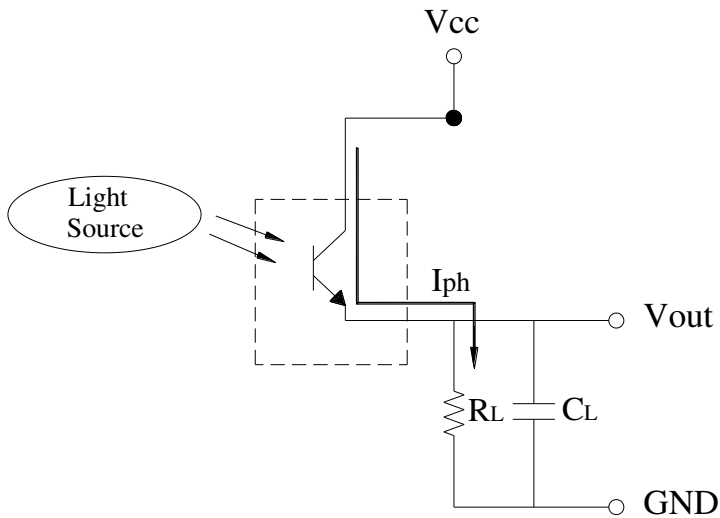

Note:

1. The output voltage ( $V_{out}$ ) is the product of photocurrent ( $I_{PH}$ ) and loading resistor ( $R_L$ )
2. A right loading resistor shall be chosen to meet the requirement of maximum ambient light, and output saturation voltage:

$$V_{out(max.)} = I_{out(max.)} \times R_L \leq V_{out(saturation)} = V_{cc} - 0.4V$$

## Packing Quantity Specification

4000 PCS/ 1 Reel

## Label Explanation



- CPN: Customer's Product Number
- P/N: Product Number
- QTY: Packing Quantity
- CAT: Luminous Intensity Rank
- HUE: Dom. Wavelength Rank
- REF: Forward Voltage Rank
- LOT No: Lot Number
- MADE IN TAIWAN: Production Place



## Recommended method of storage

Reflow Terms: JEDEC Level 4 Specification

Dry box storage is recommended as soon as the aluminum bag has been opened prevent

### 1. Over-current-proof

Customer must apply resistors for protection, otherwise slight voltage shift might cause big current happen. (Burned-out might happen).

### 2. Storage

(1) Do not open moisture proof bag before components are ready to use.

(2) Before opening moisture proof bag, components should be kept at 30°C or less and 90%RH or less.

(3) Components should be used within a year.

(4) After opened moisture proof bag, components should be kept at 30°C or less and 60%RH or less.

(5) Components should be used within 72 hours after opened moisture proof bag.

(6) If the moisture absorbent material (silica gel) has faded away or the components have exceeded the storage time, baking treatment should be performed using the following conditions.  
(Baking treatment: 60±5°C for 24 hours)

## ESD Precaution:

Proper storage and handing procedures should be followed to prevent ESD damage to the devices especially when they are removed from the anti-static bag. Electro-Static Sensitive Devices warning labels are on the packing.

## Recommended solder profile

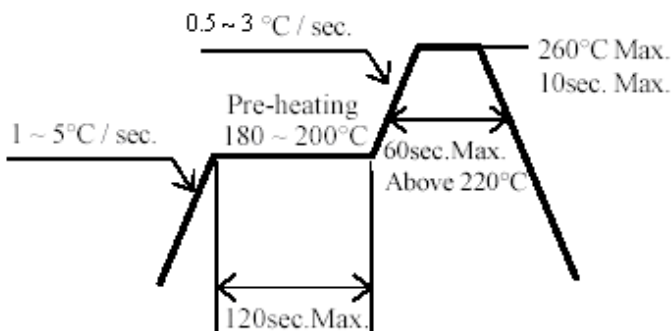

Notice:

1. Reflow soldering should not be done more than two times.
2. When soldering, do not put stress on the devices during heating.
3. After soldering, do not warp the circuit board.



## Soldering Iron

Each terminal is to go to the tip of soldering iron temperature less than 350°C for 3 seconds within once in less than the soldering iron capacity 25W. Leave two seconds and more intervals, and do soldering of each terminal. Be careful because the damage of the product is often started at the time of the hand solder.

## Repairing

Repair should not be done after the device have been soldered. When repairing is unavoidable, a double-head soldering iron should be used (as below figure). It should be confirmed beforehand whether the characteristics of the device will or will not be damaged by repairing.

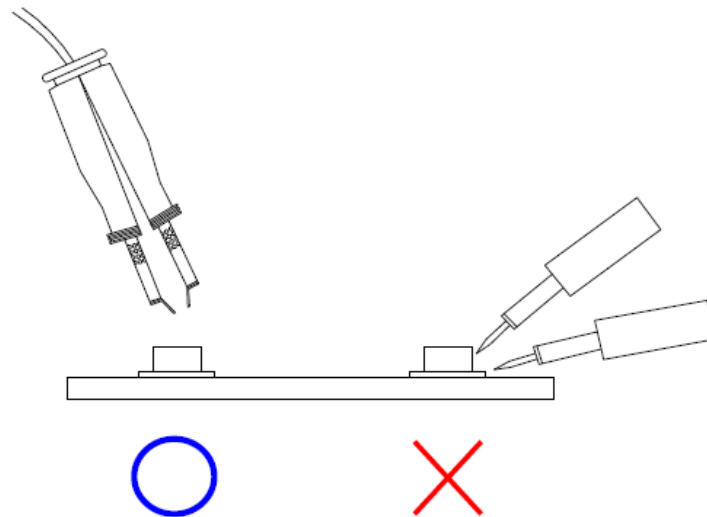

### Note:

1. Above specification may be changed without notice. Everlight Americas will reserve authority on material change for above specification.
2. When using this product, please observe the absolute maximum ratings and the instructions for using outlined in these specification sheets. Everlight Americas assumes no responsibility for any damage resulting from use of the product which does not comply with the absolute maximum ratings and the instructions included in these specification sheets.
3. These specification sheets include materials protected under copyright of Everlight Americas Inc. Please don't reproduce or cause anyone to reproduce them without Everlight Americas's consent.