

FEATURES

- Ultrasmall 0.8×0.8 mm, 4-ball, 0.4 mm pitch WLCSF
- Low $R_{DS(on)}$ of 105 m Ω @ 1.8 V
- Low input voltage range of 1.2 V to 3.6 V
- 500 mA continuous operating current
- Operating temperature range: $T_j = -40^\circ\text{C}$ to $+85^\circ\text{C}$

GENERAL DESCRIPTION

The EVAL-ADP190 is used to demonstrate the functionality of the ADP190 power switch.

Simple device measurements such as VIN to VOUT resistance ($R_{DS(on)}$), ground current, and off state current can be demonstrated with just a single voltage supply, a voltmeter, a current meter, and load resistors.

Full details about the ADP190 regulators are available in the [ADP190](#) data sheet, which should be consulted when using the EVAL-ADP190.

EVALUATION BOARD

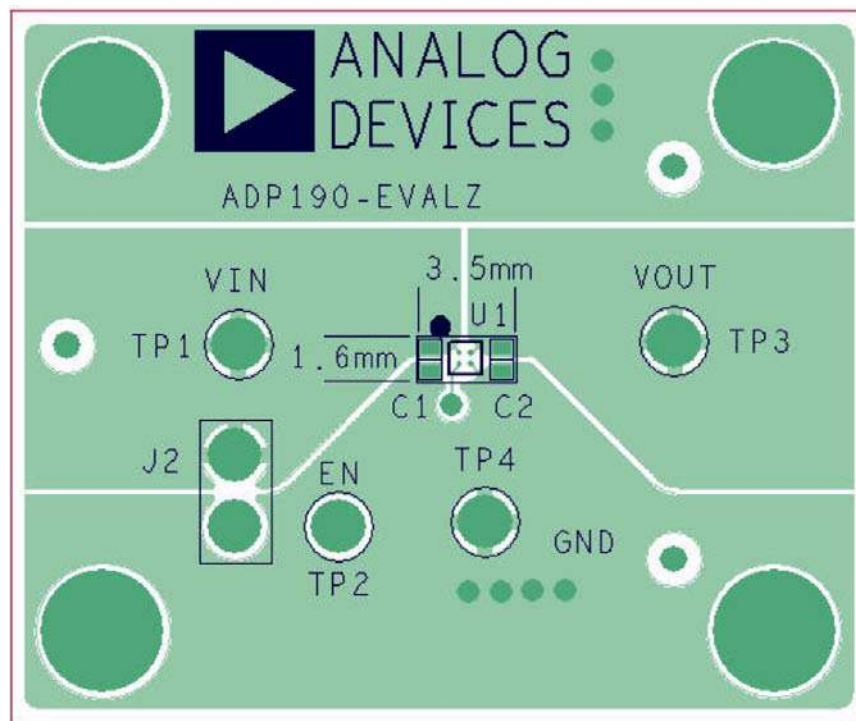

Figure 1.

Rev. 0

Evaluation boards are only intended for device evaluation and not for production purposes. Evaluation boards are supplied "as is" and without warranties of any kind, express, implied, or statutory including, but not limited to, any implied warranty of merchantability or fitness for a particular purpose. No license is granted by implication or otherwise under any patents or other intellectual property by application or use of evaluation boards. Information furnished by Analog Devices is believed to be accurate and reliable. However, no responsibility is assumed by Analog Devices for its use, nor for any infringements of patents or other rights of third parties that may result from its use. Analog Devices reserves the right to change devices or specifications at any time without notice. Trademarks and registered trademarks are the property of their respective owners. Evaluation boards are not authorized to be used in life support devices or systems.

TABLE OF CONTENTS

Features	1	Ground Current Consumption	5
General Description	1	Shutdown Current Measurement.....	6
Evaluation Board	1	Ordering Information.....	7
Revision History	2	Bill of Materials.....	7
Evaluation Board Schematic and Hardware	3	Ordering Guide	7
VIN to VOUT Resistance ($R_{DS(ON)}$)	4	ESD Caution.....	7
Ground Current Measurement.....	5		

REVISION HISTORY

2/09—Revision 0: Initial Version

EVALUATION BOARD SCHEMATIC AND HARDWARE

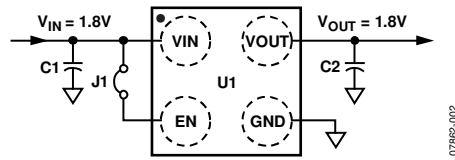

Figure 2. Evaluation Board Schematic

Table 1. Evaluation Board Hardware Components

Component	Function	Description
U1	Power switch	ADP190 high-side power switch.
C1	Input capacitor	0.1 μF input bypass capacitor. Required for stability and transient performance. Connect C1 from VIN to GND.
C2	Output capacitor	0.1 μF output capacitor. Required for stability and transient performance. Connect C2 from VOUT to GND.
J1	Jumper	Jumper. Connects EN to VIN for automatic startup.

EVAL-ADP190

VIN TO VOUT RESISTANCE ($R_{DS_{ON}}$)

$R_{DS_{ON}}$ can be measured using the configuration shown in Figure 4. $R_{DS_{ON}}$ is defined as the input-to-output voltage differential divided by load current.

The voltmeter reading divided by the load current value gives the equivalent $R_{DS_{ON}}$ value. For more accurate measurements, a second voltage meter can be used to monitor the input voltage across the input capacitor. The input supply voltage may need to be adjusted to account for IR drops, especially if large load currents are used. Figure 3 shows a typical curve of $R_{DS_{ON}}$ measurements with different load currents.

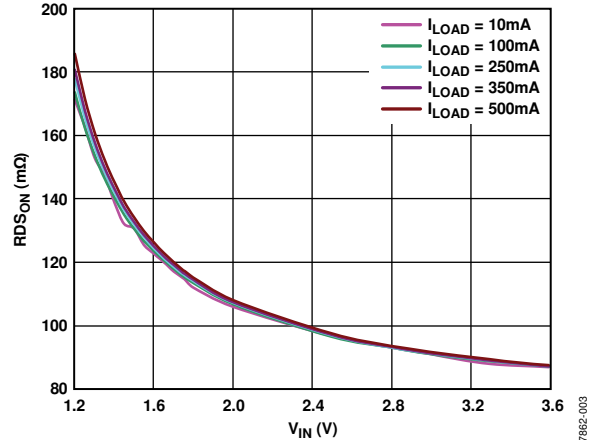

Figure 3. $R_{DS_{ON}}$ vs. Input Voltage, V_{IN} (Includes $\sim 15 m\Omega$ Trace Resistance)

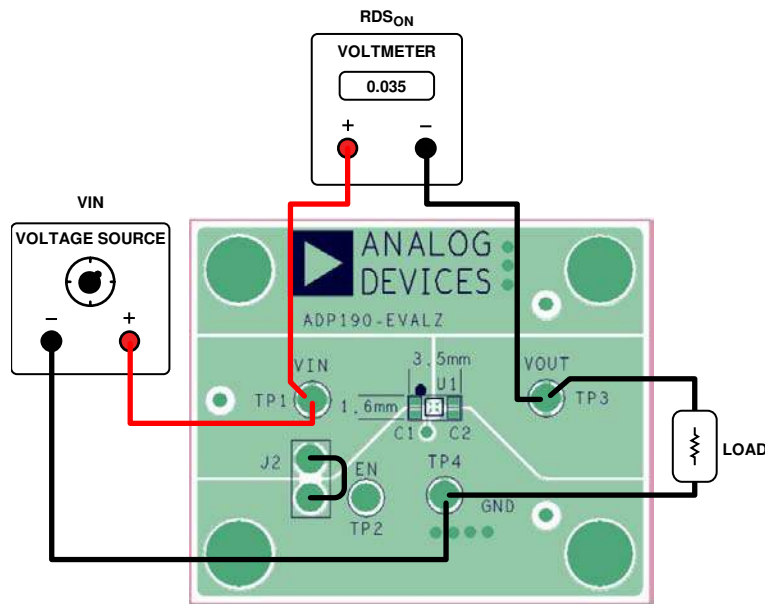

Figure 4. $R_{DS_{ON}}$ Measurement

GROUND CURRENT MEASUREMENT

Figure 6 shows how the evaluation board can be connected to a voltage source and an ammeter for ground current measurements. A resistor can be used as the load for the regulator. Ensure that the resistor has a power rating adequate to handle the power expected to be dissipated across it. An electronic load can be used as an alternative. Ensure that the voltage source used can supply enough current for the expected load levels. If voltmeters are connected at the input or output terminals, subtract the current resulting from the shunt resistance of the voltmeter for accurate ground current measurement.

Follow these steps to connect to a voltage source and ammeter:

1. Connect the positive terminal (+) of the voltage source to the VIN pad on the evaluation board.
2. Connect the positive terminal (+) of the ammeter to one of the GND pads of the evaluation board.
3. Connect the negative terminal (-) of the ammeter to the negative (-) terminal of the voltage source.
4. Connect a load between the VOUT pad of the evaluation board and the negative (-) terminal of the voltage source.

The voltage source can now be turned on. If J1 is inserted (connecting EN to VIN for automatic startup), the regulator powers up.

GROUND CURRENT CONSUMPTION

Ground current measurement is a way of determining how much current the internal circuits of the regulator are consuming, while performing the power switch function. To be efficient, the power switch needs to consume as little current as possible. Figure 5 shows the typical ground current consumption for various load levels.

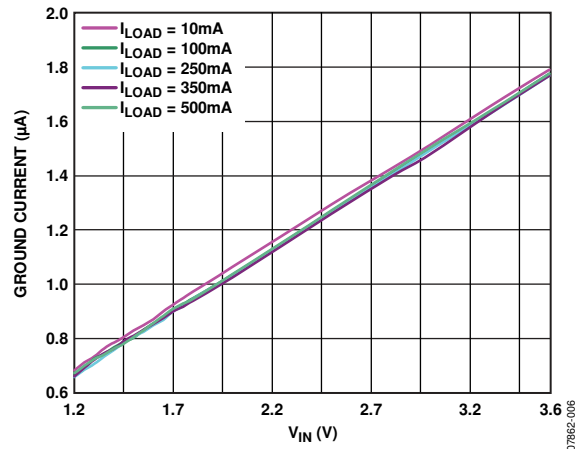

Figure 5. Ground Current vs. Input Voltage, V_{IN}

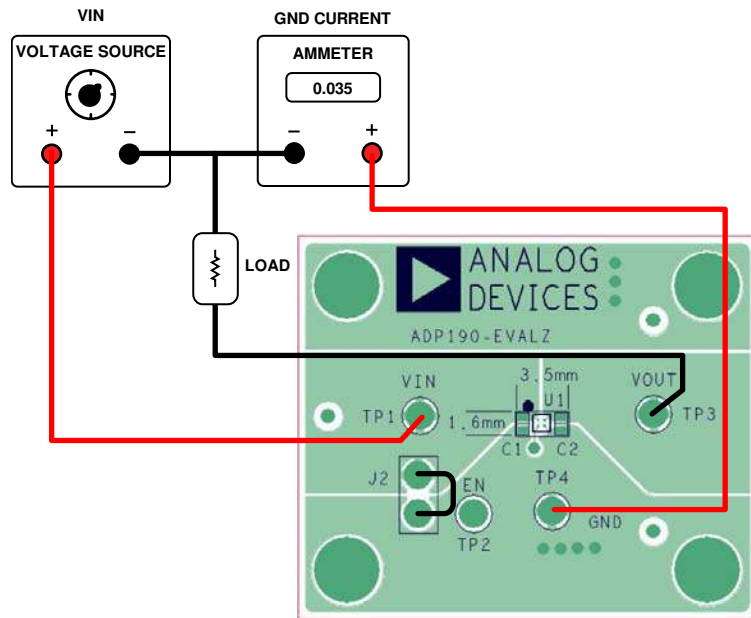

Figure 6. Ground Current Measurement

SHUTDOWN CURRENT MEASUREMENT

Figure 8 shows how the evaluation board can be connected to a voltage source and an ammeter for shutdown current measurements. The ammeter can also be connected to the GND terminal to measure the ground current, which is equal to the shutdown current when EN is tied to ground. Figure 7 shows the typical shutdown current consumption for various input voltages.

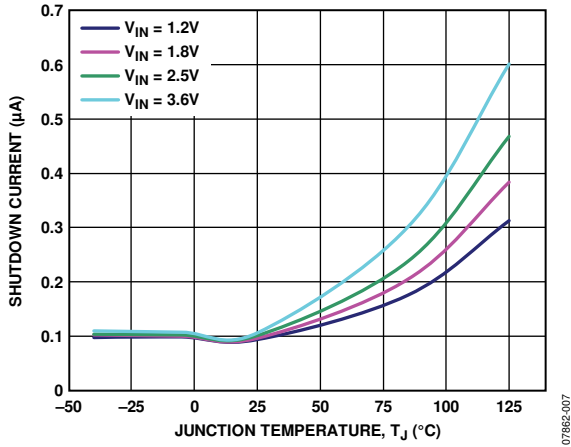

Figure 7. Shutdown Current vs. Temperature and Input Voltage

Follow these steps to connect to a voltage source and ammeter:

1. Connect the positive terminal (+) of the voltage source to the (+) of the ammeter.
2. Connect the negative (-) terminal of the voltage source to GND pad on the evaluation board.
3. Connect the negative terminal (-) of the ammeter to the VIN pad on the evaluation board.
4. Connect the EN pin to ground using Jumper J1.

The voltage source can now be turned on.

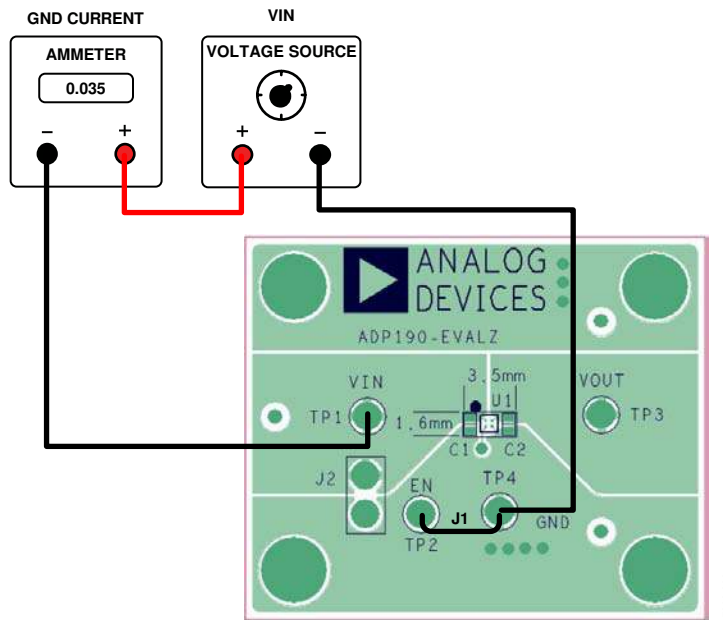

Figure 8. Shutdown Current Measurement

ORDERING INFORMATION

BILL OF MATERIALS

Table 2.

Qty	Reference Designator	Description	Manufacturer/Vendor	Vendor Part No.
2	C1, C2	Capacitor, MLCC, 0.1 µF, 10 V, 0402, X5R	Murata or equivalent	GRM155R61A104KA01D
1	J1	Header, single, STR, 2 pins	Digi-Key Corp.	S1012E-36-ND
1	U1	IC, power switch	Analog Devices, Inc.	ADP190

ORDERING GUIDE

Model	Description
ADP190CB-EVALZ ¹	Evaluation Board

¹ Z = RoHS Compliant Part.

ESD CAUTION



ESD (electrostatic discharge) sensitive device. Charged devices and circuit boards can discharge without detection. Although this product features patented or proprietary protection circuitry, damage may occur on devices subjected to high energy ESD. Therefore, proper ESD precautions should be taken to avoid performance degradation or loss of functionality.

NOTES