

LOC		DIST		REVISIONS			
P	LTN	DESCRIPTION	DATE	DWN	APVD		
B		ECO-06-005597	13MAR2006	LAM	PR		
C		ECO-06-009340	21APR2006	LAM	PR		
D		ECO-07-007895	27APR2007	LAM	PR		
D1		MODIFIED AS PER ECR-23-169440	30MAR2023	KV	HW		

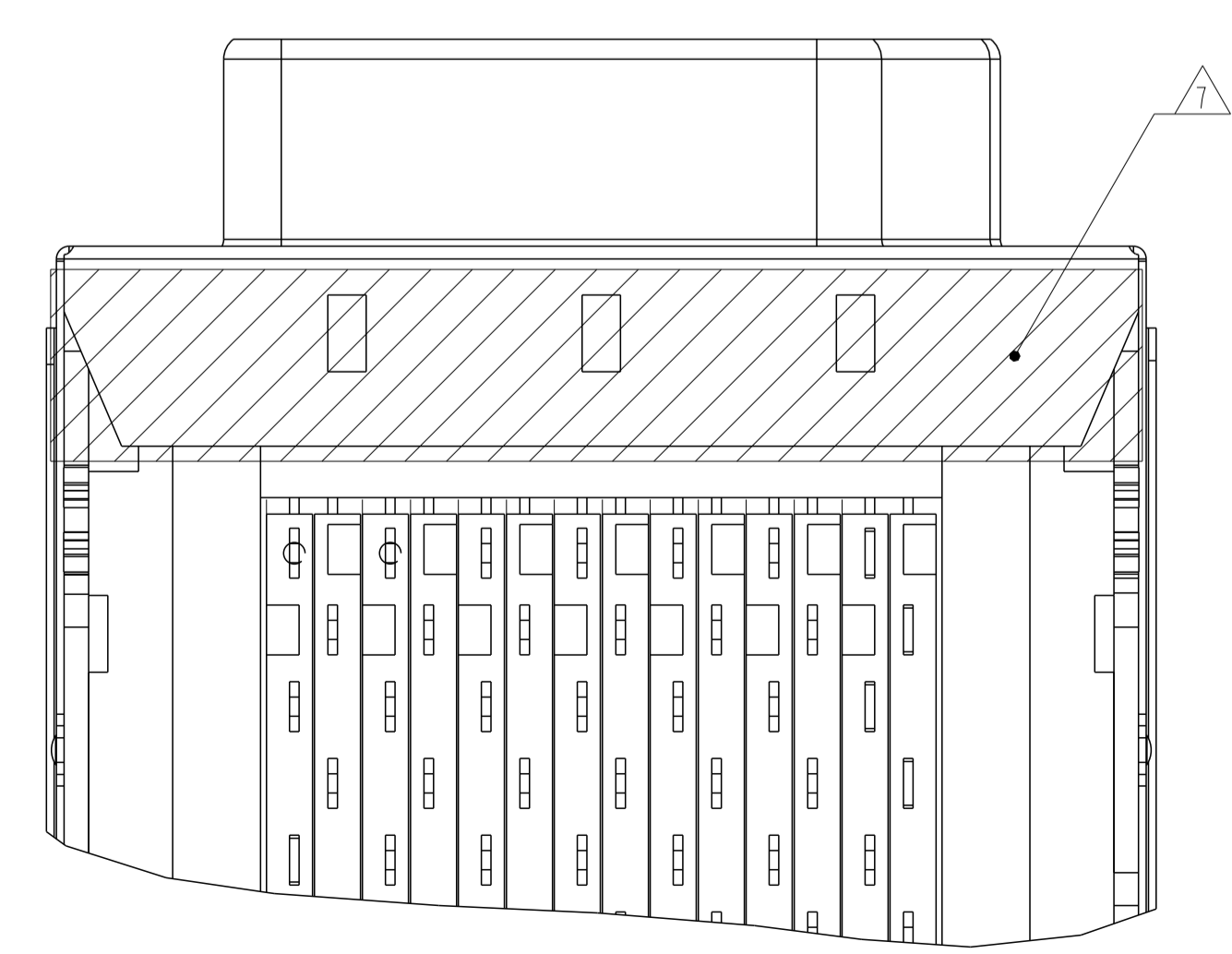

1. MATERIAL:
 HOUSING - BLACK THERMOPLASTIC, PBT FLAMMABILITY RATING UL 94V-0
 SHIELD - 0.2 MM THICK BRASS - PLATED WITH 1.27um(0.000050)min THICK NICKEL AND HOT TIN DIP ON PCB GROUND TABS (EXCEPT 1761715-2 DOES NOT HAVE TIN)
 FRONT DRAWN SHELL - CARBON STEEL - PLATED WITH 5.08um MIN NICKEL
 BOARD LOCKS - BRASS PLATED WITH 1.27um MIN TIN OVER 1.27um MIN NICKEL
 CONTACTS - 0.254 MM THK. PHOSPHOR BRONZE - ENTIRE TERMINAL PLATED WITH 2.54um MIN NICKEL. MATING AREA PLATED WITH GOLD FLASH OVER 0.76um MIN Pd-Ni. SOLDER TAILS WITH PLATED 1.98um MIN TIN
 INSERTS, THREADED - MILD STEEL
 SCREW LOCKS - STAINLESS STEEL
- 3 THE SCREW LOCKS ARE FOR USE WITH JACKSCREWS TO PROVIDE CABLE RETENTION.
- 4 RECOMMENDED TORQUE FOR SCREW LOCK IS 4 IN-LB. FOR PANEL MOUNTED VERSION, 1761715-1 AND 1761715-2.
- 5 SCREW LOCK DESIGNATION:
 SCREW LOCKS MUST BE ORDERED SEPARATELY FROM TABLE BELOW. SCREW LOCKS PACKAGED IN QUANTITIES OF 960 PIECES.
- | | |
|-----------------|----------------|
| > 1mm - < 2mm | 1339381-2 |
| 0mm - ≤ 1mm | 1339381-1 |
| PANEL THICKNESS | SCREW LOCK P/N |
- 6 DATE CODE AND PART NUMBER LABEL IN APPROXIMATE AREA SHOWN.
- 7 0.05 THK. INSULATING TAPE WITH 0.05 MIN THK. ADHESIVE BACKING IN AREA SHOWN.
- 8 DATUM AND BASIC DIMENSIONS ESTABLISHED BY CUSTOMER

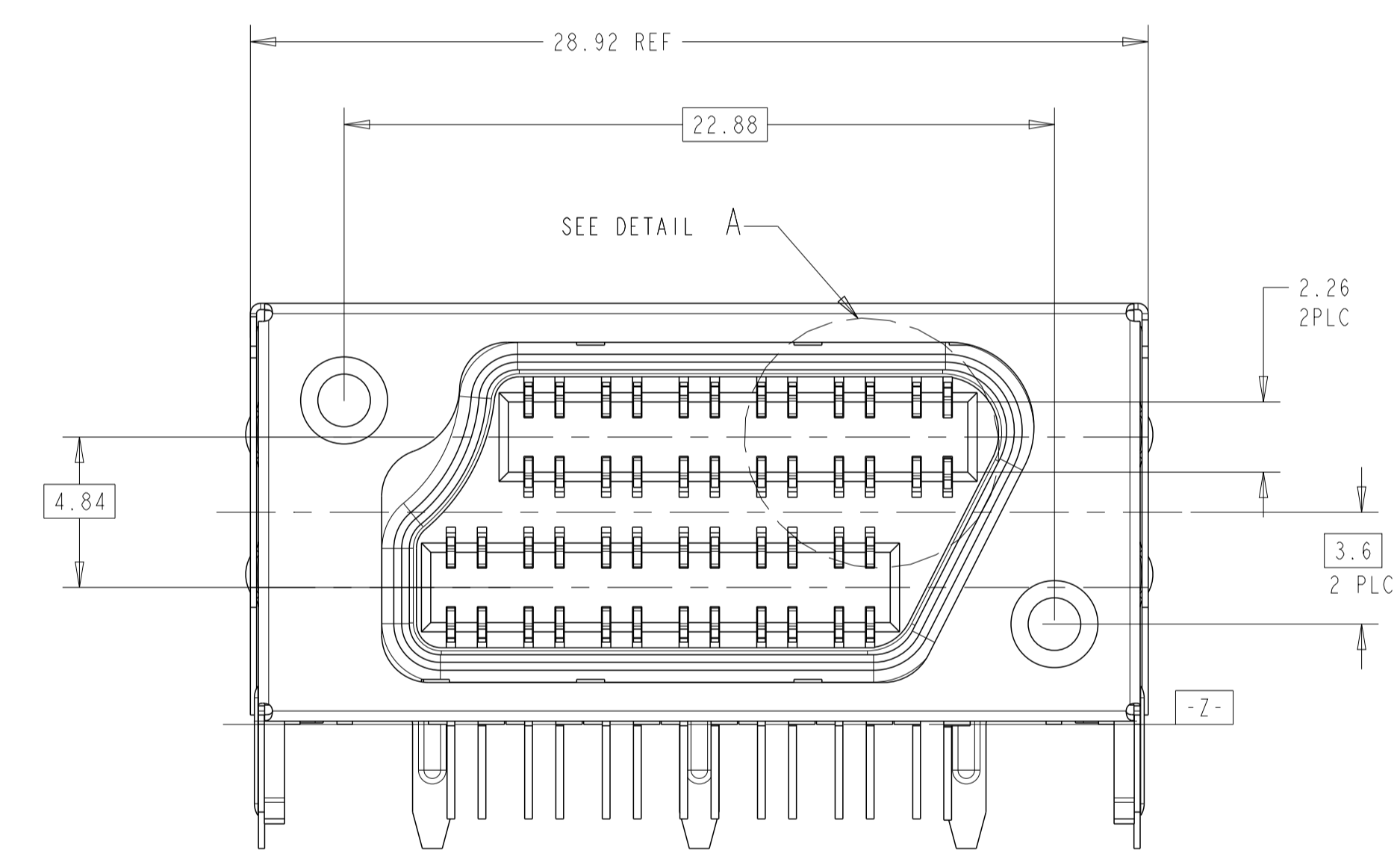
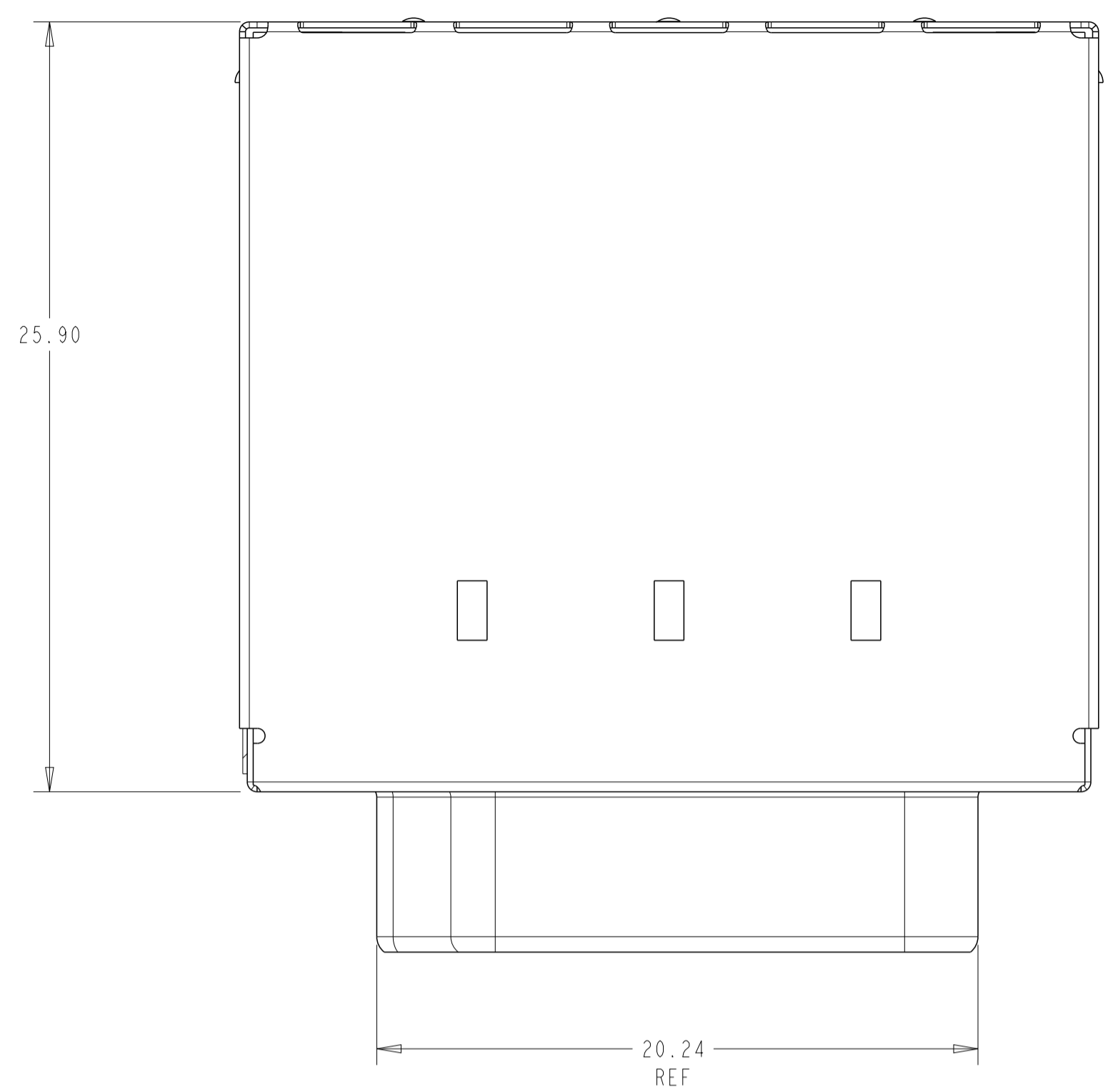
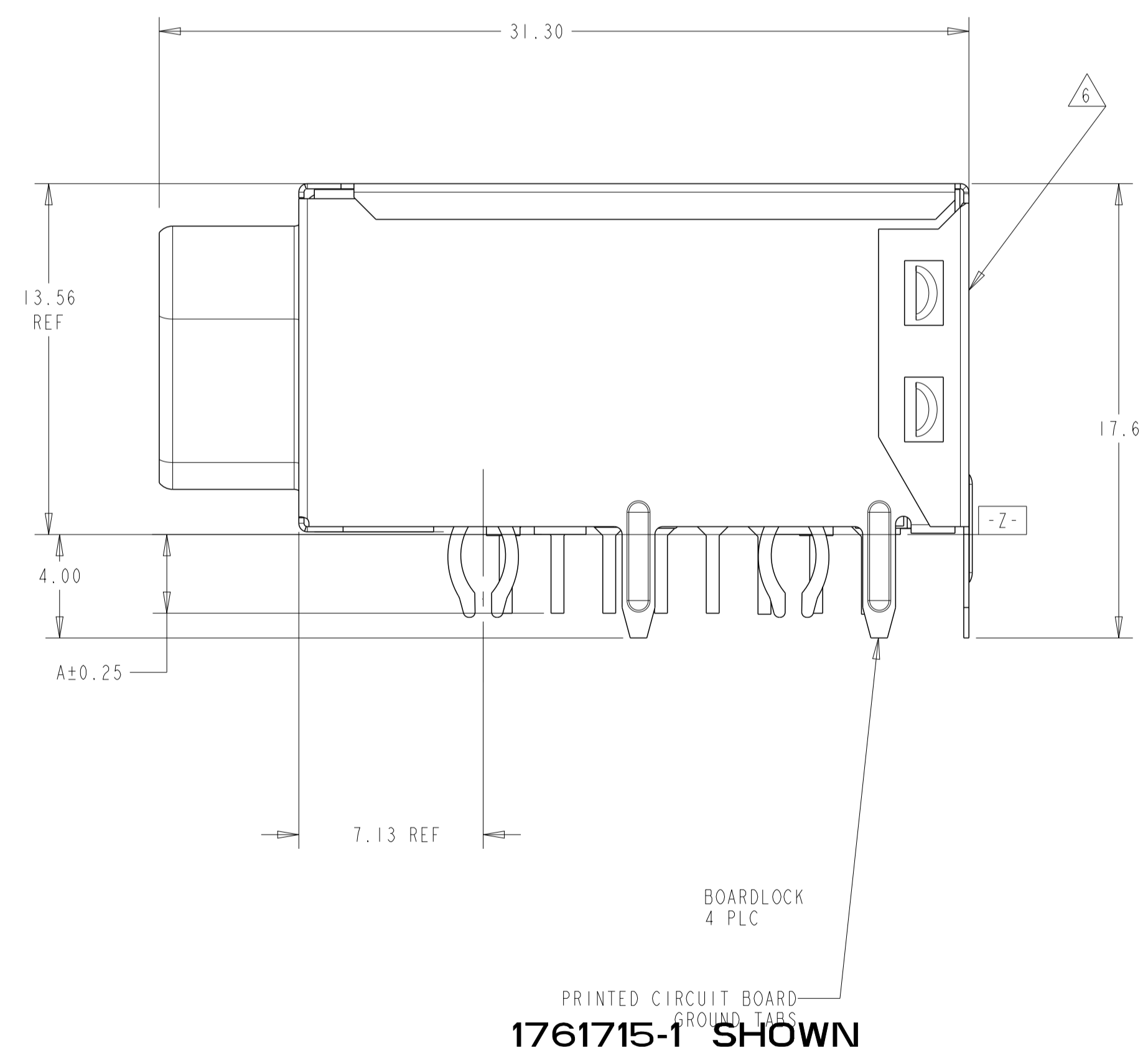

PRESS-FIT	3.04	1761715-2
SOLDERTAIL	4.54	1761715-1
TERMINATION	DIM "A"	PART NUMBER

<small>THIS IS DRAWING IS A CONTROLLED DOCUMENT FROM TYCO ELECTRONICS CORPORATION. IT IS THE POLICY OF COMPANY TO CONTROL AND RESTRICTING DISTRIBUTION. SHOULD BE CONTACTED FOR THE LATEST REVISION.</small>		DWN: R. GRZYBOWSKI CHK: M. YEOMANS APVD: S. FLICKINGER	Tyco Electronics Harrisburg, PA 17105-3608
DIMENSIONS: mm 	TOLERANCES UNLESS OTHERWISE SPECIFIED: 0 PLC ± 1 PLC ±0.1 2 PLC ±0.10 3 PLC ± 4 PLC ± ANGLES ±2°	NAME: ASSEMBLY, RECEPTACLE, 48 POSITION, MR J21 PRODUCT SPEC: 108-2064 APPLICATION SPEC:	RESTRICTED TO:
MATERIAL: SEE NOTE 1 FINISH:	WEIGHT:	SIZE: A1 CAGE CODE: 00779 DRAWING NO: 1761715	SCALE: 11:2 SHEET: 1 OF 4 REV: D1
CUSTOMER DRAWING			

LOC	DIST	REVISIONS					
AA	00	P	LTN	DESCRIPTION	DATE	DWN	APVD
		-		SEE SHEET 1			

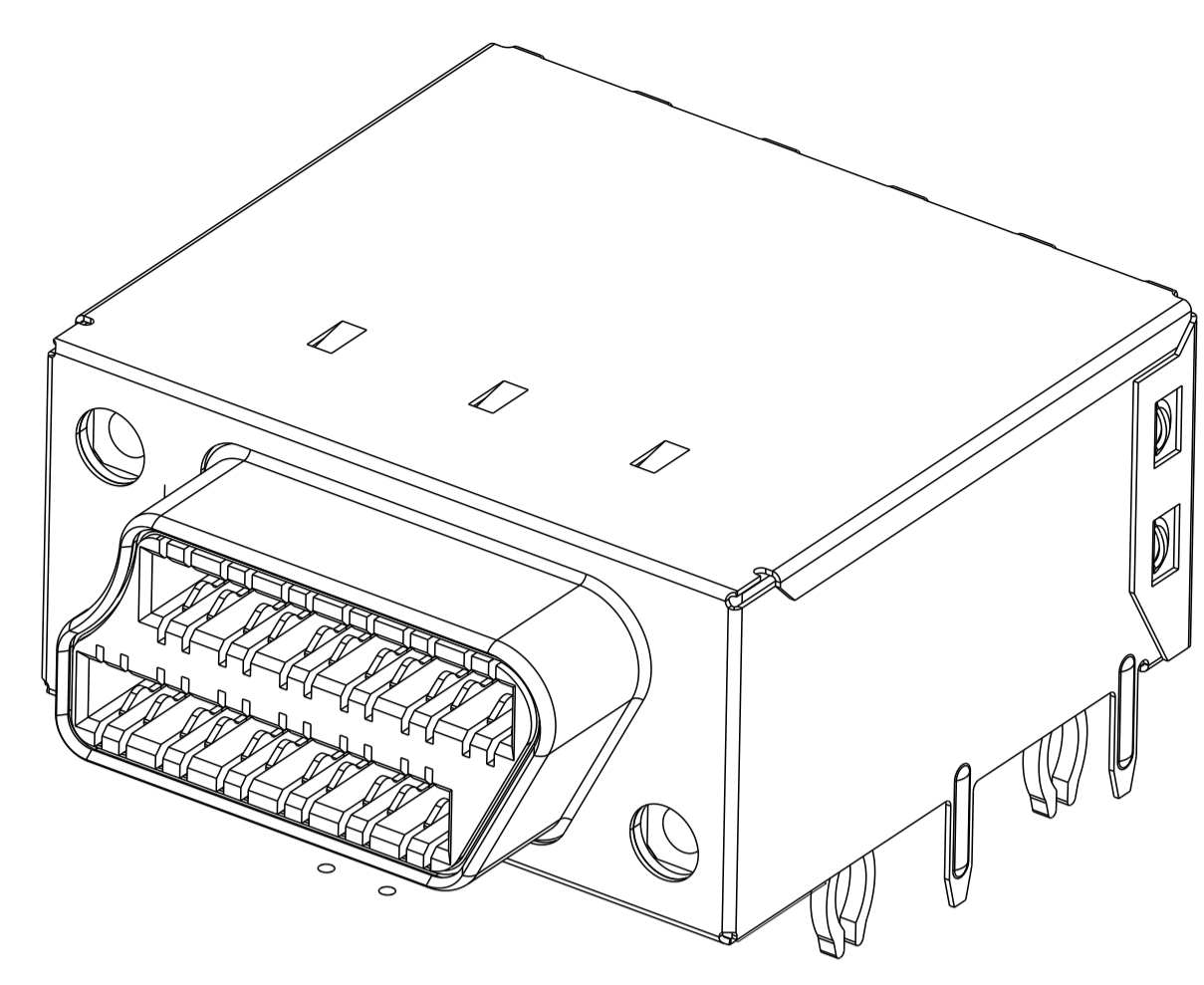

1761715-1
SCALE 4:1

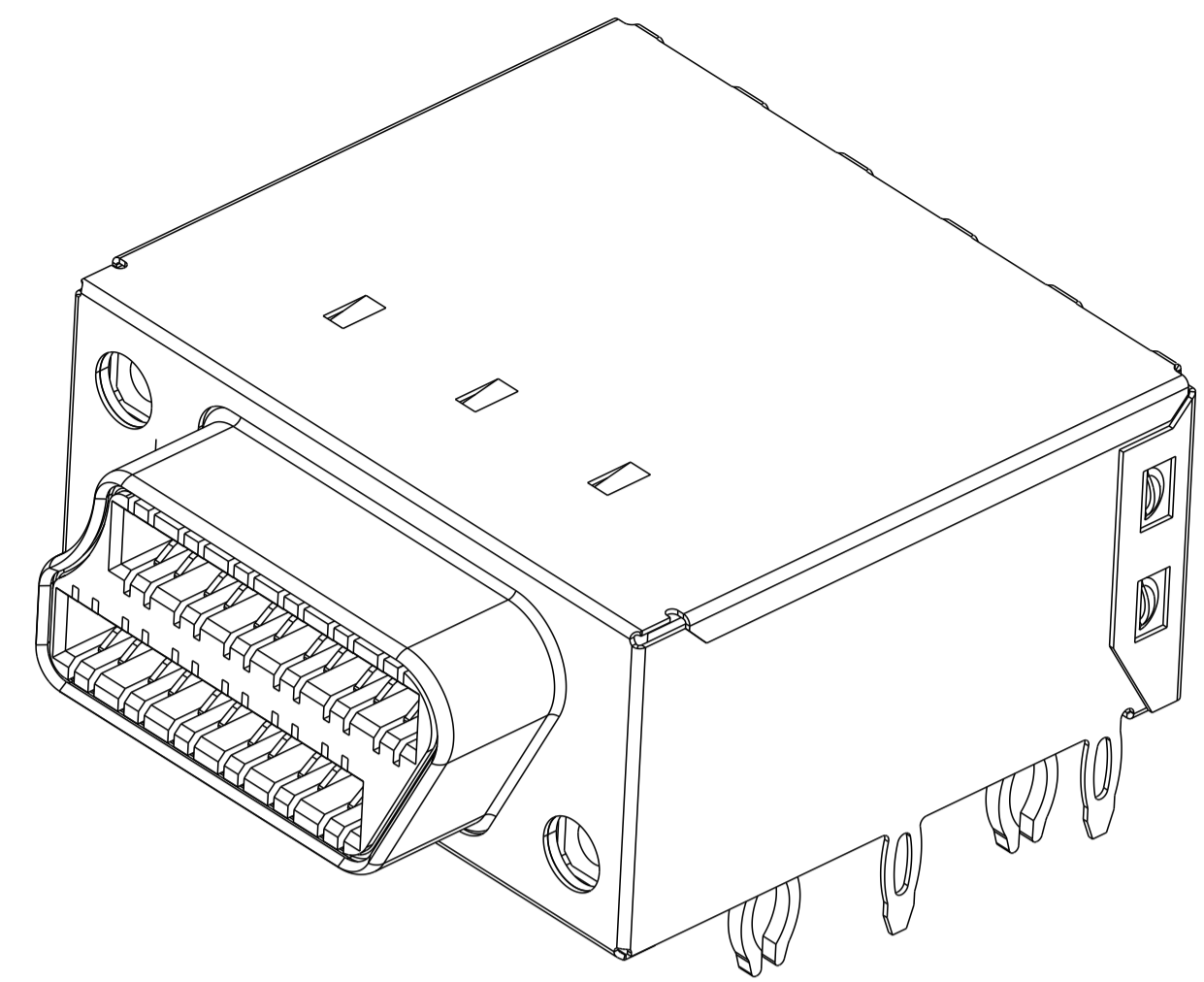

1761715-2
PRESS-FIT VERSION
SCALE 4:1

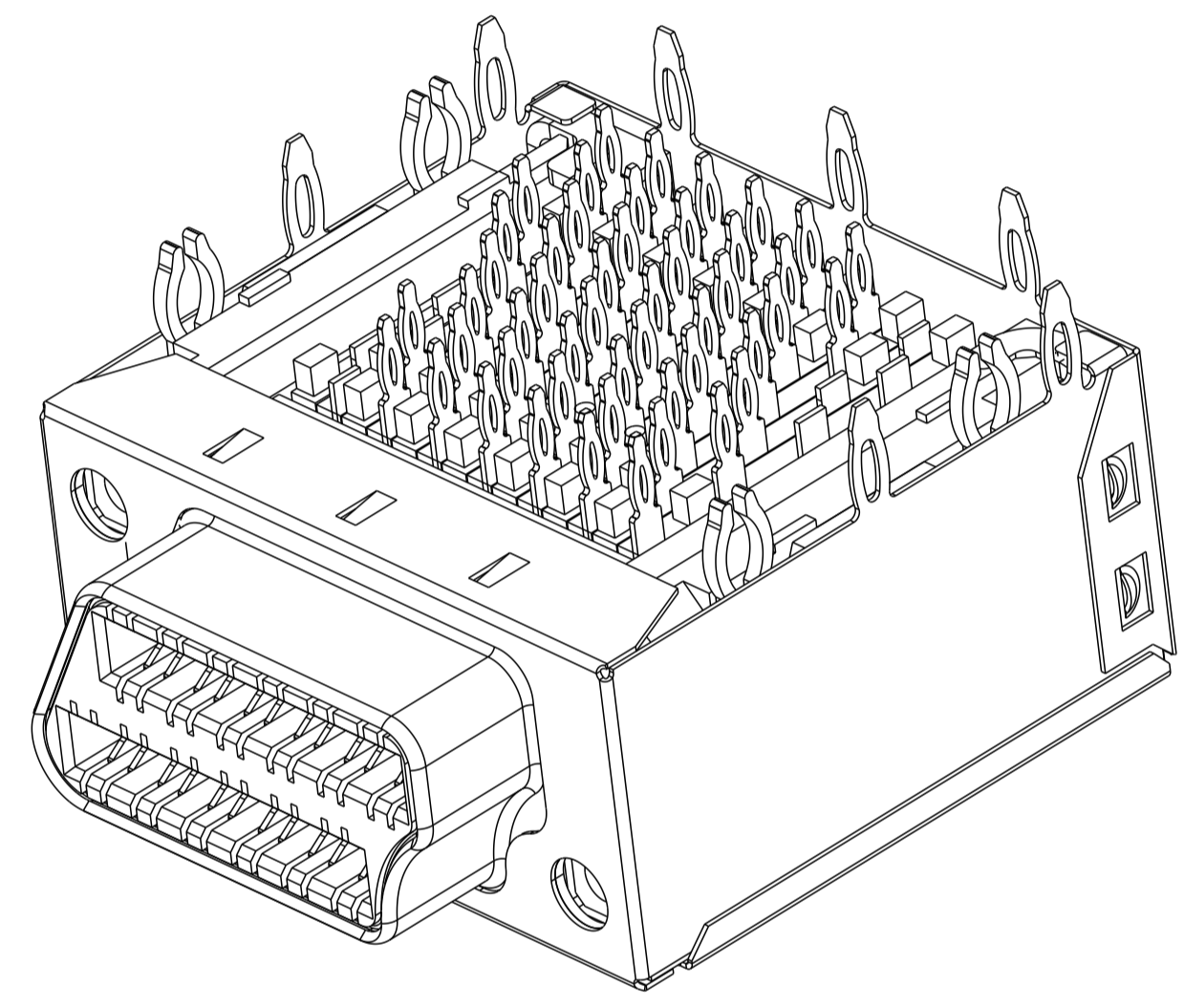

PRESS-FIT
BOTTOM VIEW
SCALE 4:1

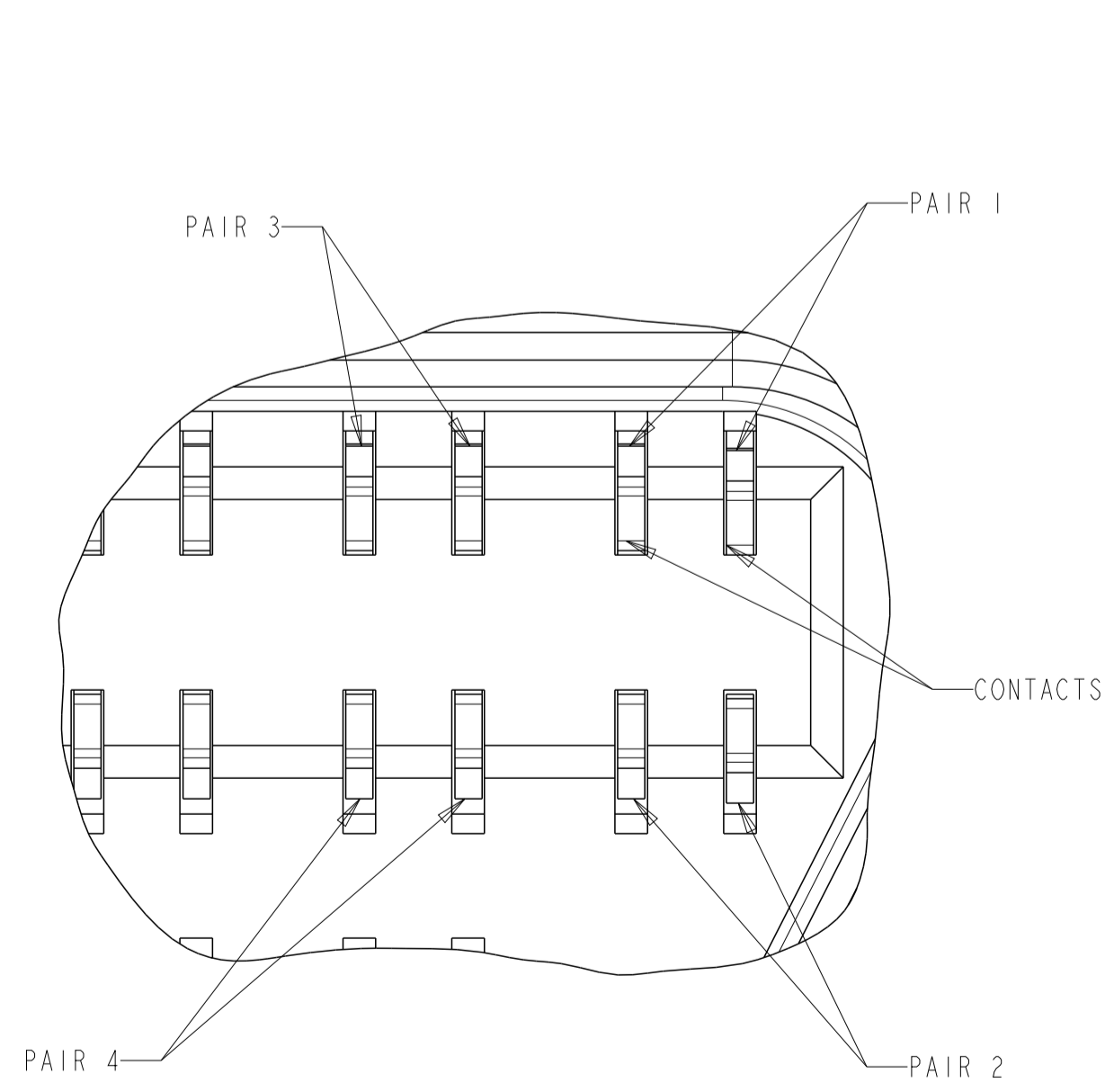

DETAIL A
SCALE 16:1

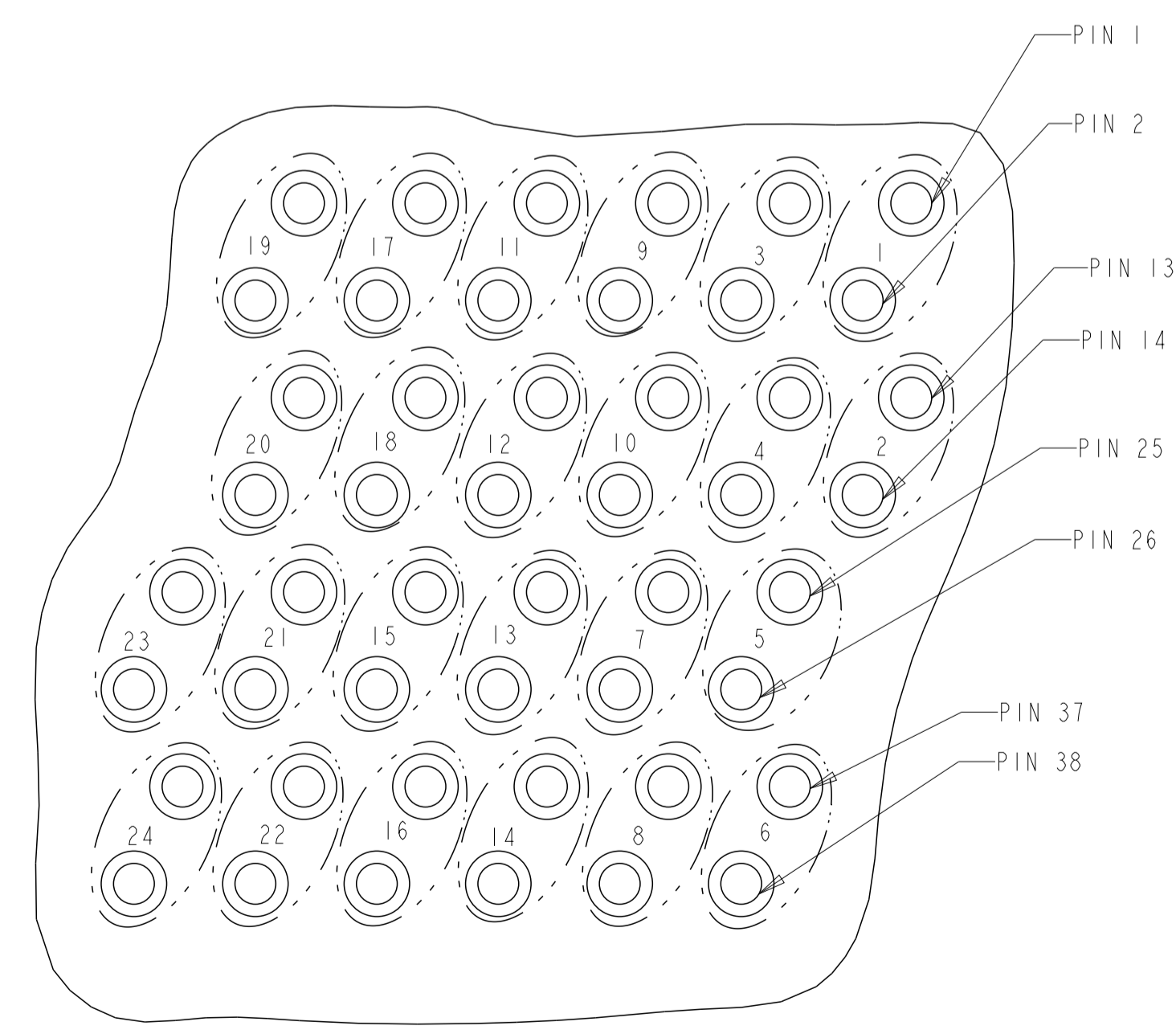

PROPOSED PAIR GROUPING

MODULAR PLUG AND RJ-21 PIN-OUT FOR USE IN 10/100/1000 BASE-T APPLICATIONS

GIG ETHERNET PORT	PLUG POSN.	COLOR	10/100 ETHERNET PORT	PLUG POSN.	COLOR	RJ-21 PIN	MRJ 21 PIN	MRJ 21 PAIR NUM	
1	5	WHT/BLU	1	1	WHT/BLU	26	1	1	
	4	BLU/WHT		2	BLU/WHT	1	2		
	3	WHT/ORG		3	WHT/ORN	27	13	2	
	6	ORG/WHT		6	ORN/WHT	2	14		
	2	1	WHT/GRN	2	1	WHT/GRN	28	3	3
		2	GRN/WHT		2	GRN/WHT	3	4	
		7	WHT/BRN		3	WHT/BRN	29	15	4
		8	BRN/WHT		6	BRN/WHT	4	16	
3		5	WHT/GRY	3	1	WHT/GRY	30	25	5
		4	GRY/WHT		2	GRY/WHT	5	26	
		3	RED/BLU		3	RED/BLU	31	37	6
		6	BLU/RED		6	BLU/RED	6	38	
	4	1	RED/ORG	4	1	RED/ORN	32	27	7
		2	ORG/RED		2	ORN/RED	7	28	
		7	RED/GRN		3	RED/GRN	33	39	8
		8	GRN/RED		6	GRN/RED	8	40	
5		5	RED/BRN	5	1	RED/BRN	34	5	9
		4	BRN/RED		2	BRN/RED	9	6	
		3	RED/GRY		3	RED/GRAY	35	17	10
		6	GRY/RED		6	GRY/RED	10	18	
	6	1	BLK/BLU	6	1	BLK/BLU	36	7	11
		2	BLU/BLK		2	BLU/BLK	11	8	
		7	BLK/ORG		3	BLK/ORN	37	19	12
		8	ORG/BLK		6	ORN/BLK	12	20	
7		5	BLK/GRN	7	1	BLK/GRN	38	29	13
		4	GRN/BLK		2	GRN/BLK	13	30	
		3	BLK/BRN		3	BLK/BRN	39	41	14
		6	BRN/BLK		6	BRN/BLK	14	42	
	8	1	BLK/GRY	8	1	BLK/GRY	40	31	15
		2	GRY/BLK		2	GRY/BLK	15	32	
		7	YEL/BLU		3	YEL/BLU	41	43	16
		8	BLU/YEL		6	BLU/YEL	16	44	
9		5	YEL/ORG	9	1	YEL/ORN	42	9	17
		4	ORG/YEL		2	ORN/YEL	17	10	
		3	YEL/GRN		3	YEL/GRN	43	21	18
		6	GRN/YEL		6	GRN/YEL	18	22	
	10	1	YEL/BRN	10	1	YEL/BR	44	11	19
		2	BRN/YEL		2	BR/YEL	19	12	
		7	YEL/GRY		3	YEL/GRY	45	23	20
		8	GRY/YEL		6	GRY/YEL	20	24	
11		5	VIO/BLU	11	1	VIO/BLU	46	33	21
		4	BLU/VIO		2	BLU/VIO	21	34	
		3	VIO/ORG		3	VIO/ORN	47	45	22
		6	ORG/VIO		6	ORN/VIO	22	46	
	12	1	VIO/GRN	12	1	VIO/GRN	48	35	23
		2	GRN/VIO		2	GRN/VIO	23	36	
		7	VIO/BRN		3	VIO/BRN	49	47	24
		8	BRN/VIO		6	BRN/VIO	24	48	

DIMENSIONS: mm
 TOLERANCES UNLESS OTHERWISE SPECIFIED:
 0 PLC ±
 1 PLC ±0.1
 2 PLC ±0.10
 3 PLC ±
 4 PLC ±
 ANGLES ±
 FINISH ±

MATERIAL: SEE NOTE 1
 FINISH:

DWG: R. GRZYBOWSKI
 CHK: M. YEOMANS
 APVD: S. FLICKINGER
 PRODUCT SPEC: 108-2064
 APPLICATION SPEC:

DATE: 03FEB2006
 NAME: ASSEMBLY, RECEPTACLE, 48 POSITION, MR J21
 SIZE: A1
 CAGE CODE: 00779
 DRAWING NO: 1761715
 SHEET 2 OF 4
 REV: D1

Tyco Electronics
 Harrisburg, PA 17105-3608

CUSTOMER DRAWING
 SCALE: 6:1

LOC	DIST	REVISIONS			
P	LTN	DESCRIPTION	DATE	DMN	APVD
-	-	SEE SHEET 1	-	-	-

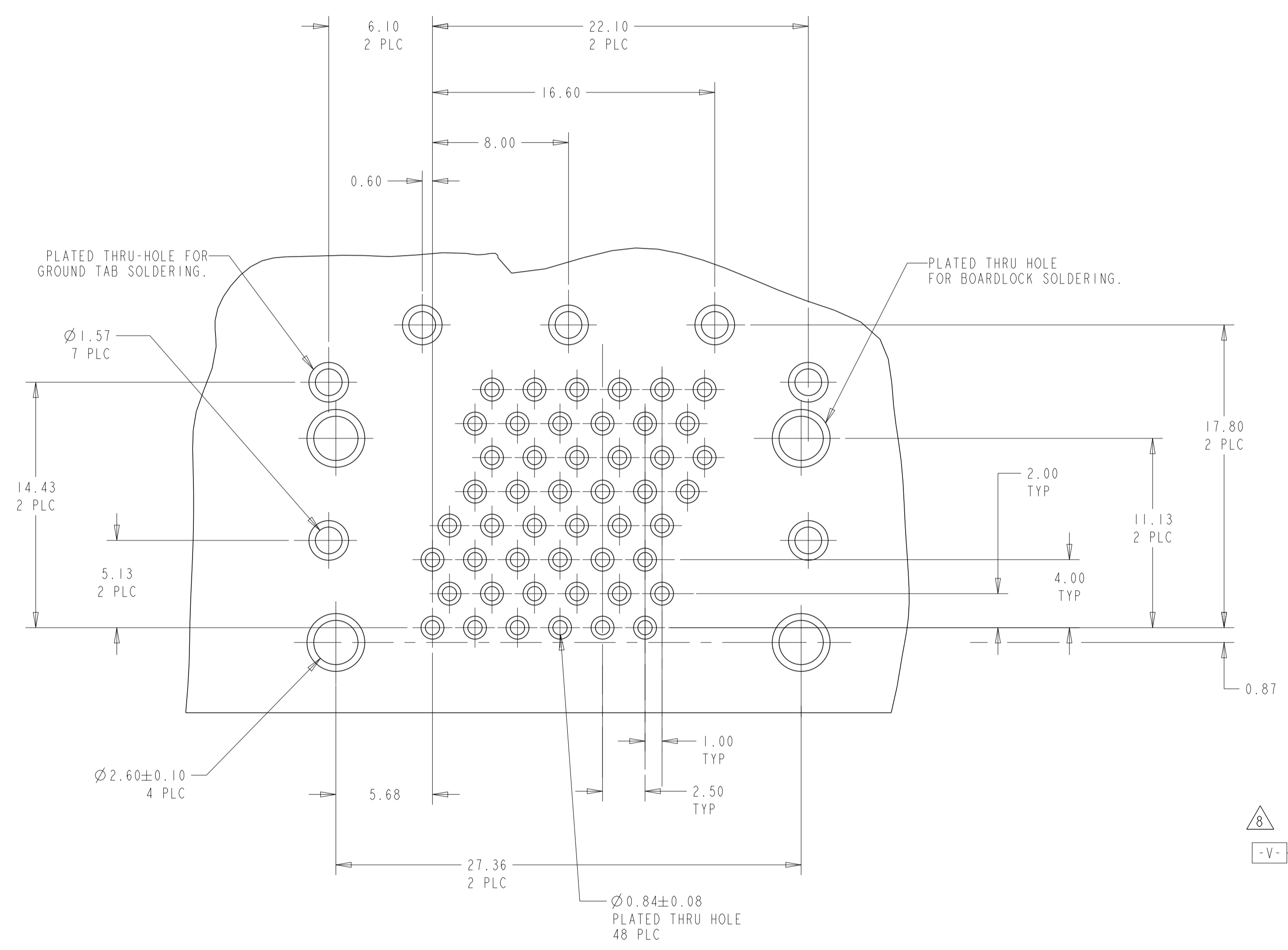

PCB LAYOUT
 FOR SOLDER TAILS
 COMPONENT SIDE
 SCALE 5:1

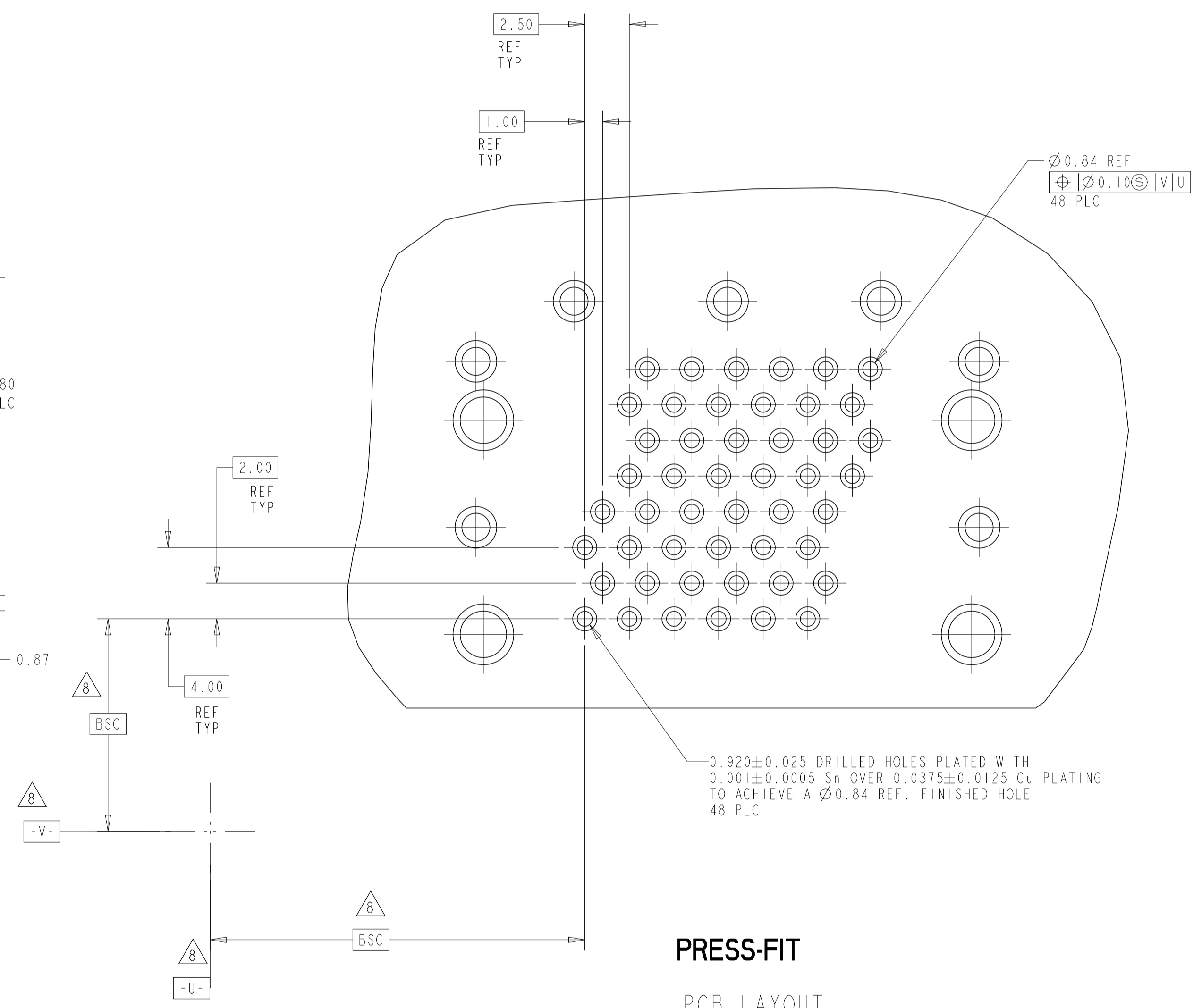

PRESS-FIT
 PCB LAYOUT
 SAME AS -1 EXCEPT AS NOTED
 SCALE 5:1

<small>THIS DRAWING IS UNPUBLISHED. RELEASED FOR PUBLICATION 20. COPYRIGHT 20 BY TYCO ELECTRONICS CORPORATION. ALL RIGHTS RESERVED.</small>		DWN: R. GRZYBOWSKI 03FEB2006 CHK: M. YEOMANS 03FEB2006 APVD: S. FLICKINGER 03FEB2006	Tyco Electronics Harrisburg, PA 17105-3608
DIMENSIONS: mm 	TOLERANCES UNLESS OTHERWISE SPECIFIED: 0 PLC ± 1 PLC ±0.1 2 PLC ±0.10 3 PLC ± 4 PLC ± ANGLES ±2° FINISH -	NAME: ASSEMBLY, RECEPTACLE, 48 POSITION, MR J21 PRODUCT SPEC: 108-2064 APPLICATION SPEC:	SIZE: A1 CAGE CODE: 00779 DRAWING NO: 1761715 RESTRICTED TO:
MATERIAL: SEE NOTE 1	WEIGHT:	CUSTOMER DRAWING	SCALE: 6:1 SHEET: 3 OF 4 REV: D1

LOC	DIST	REV	DATE	BY	APPV
AA	00				

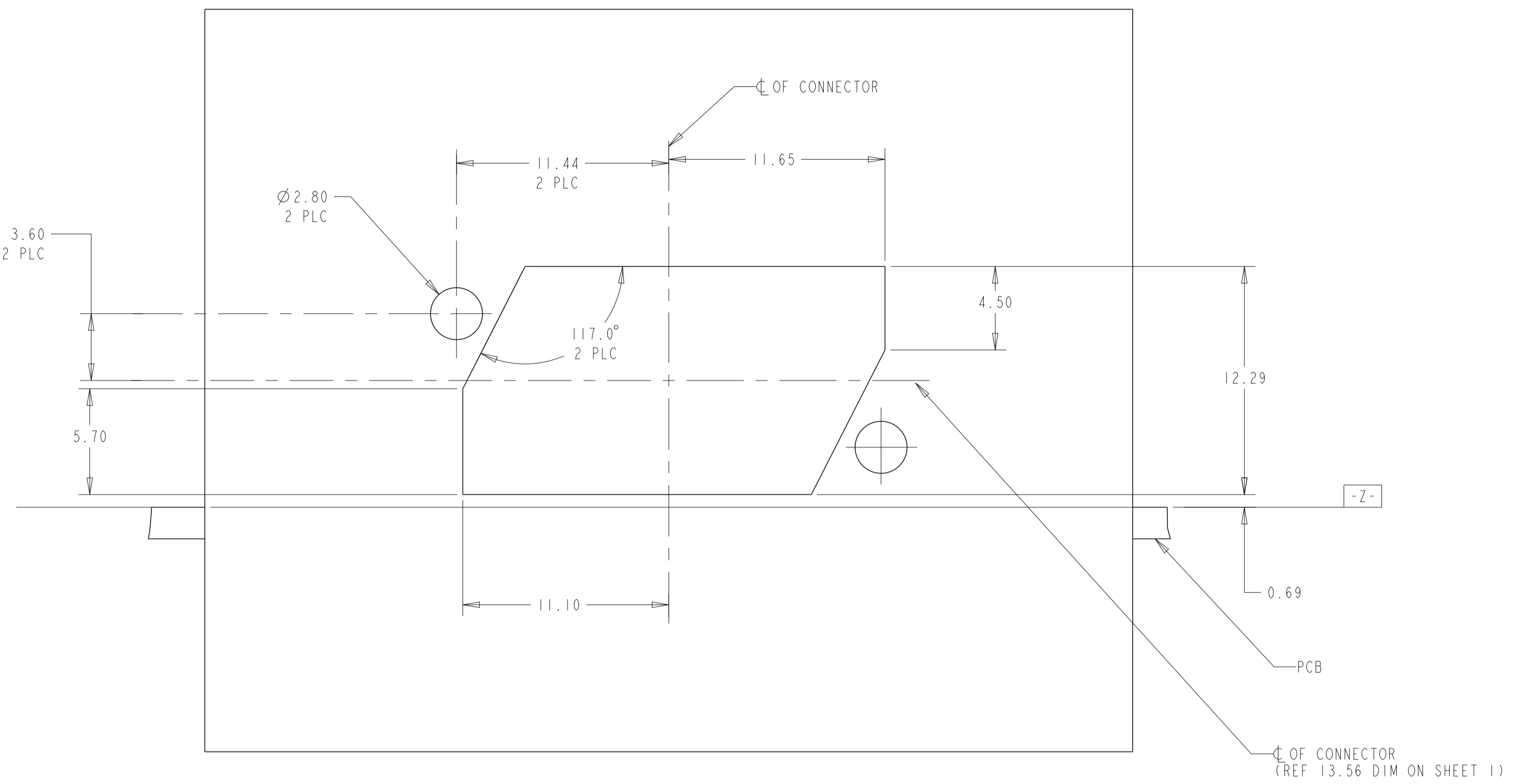

RECOMMENDED PANEL CUTOUT (NO PANEL GROUNDS)
 SCALE 5:1

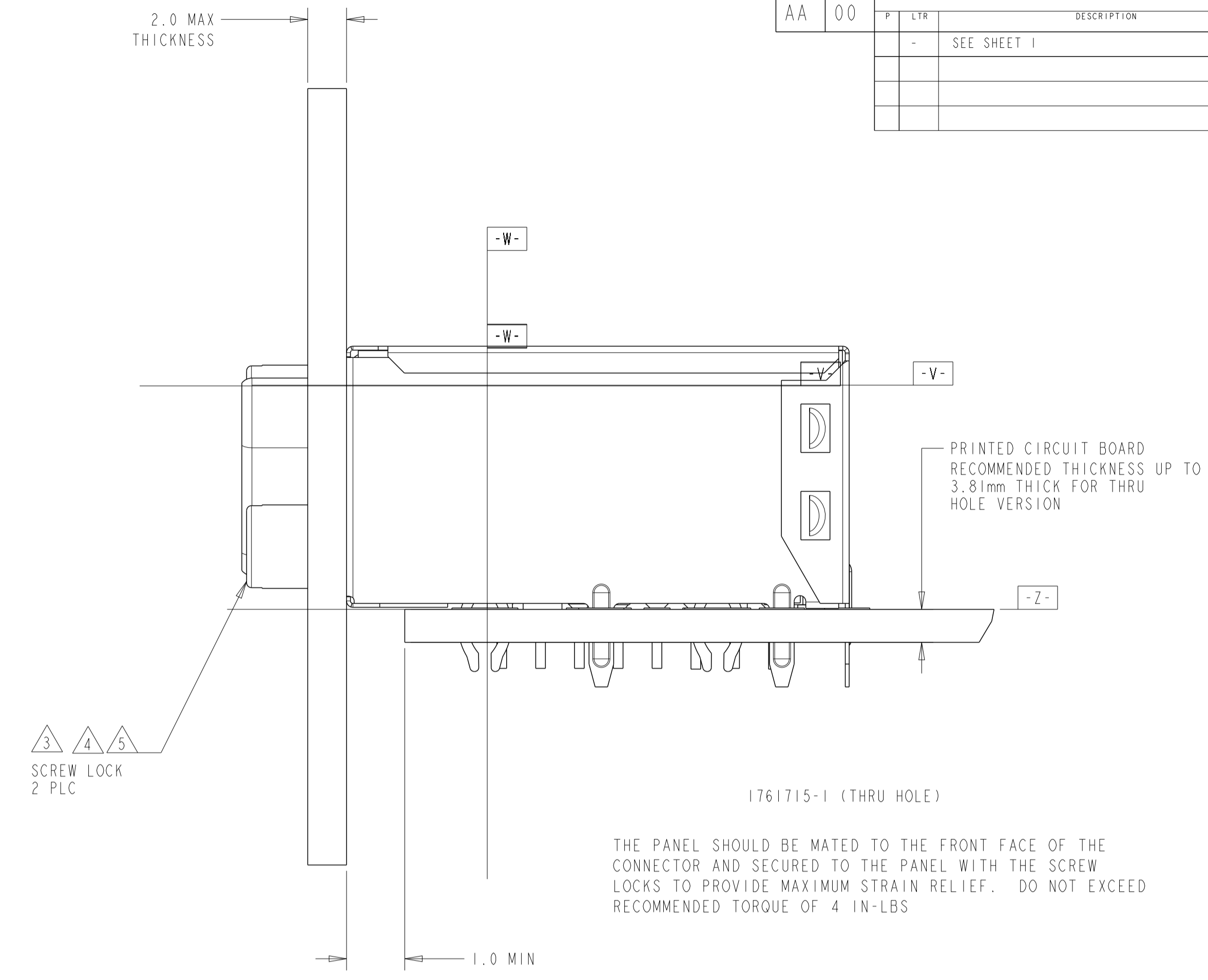

THE PANEL SHOULD BE MATED TO THE FRONT FACE OF THE CONNECTOR AND SECURED TO THE PANEL WITH THE SCREW LOCKS TO PROVIDE MAXIMUM STRAIN RELIEF. DO NOT EXCEED RECOMMENDED TORQUE OF 4 IN-LBS

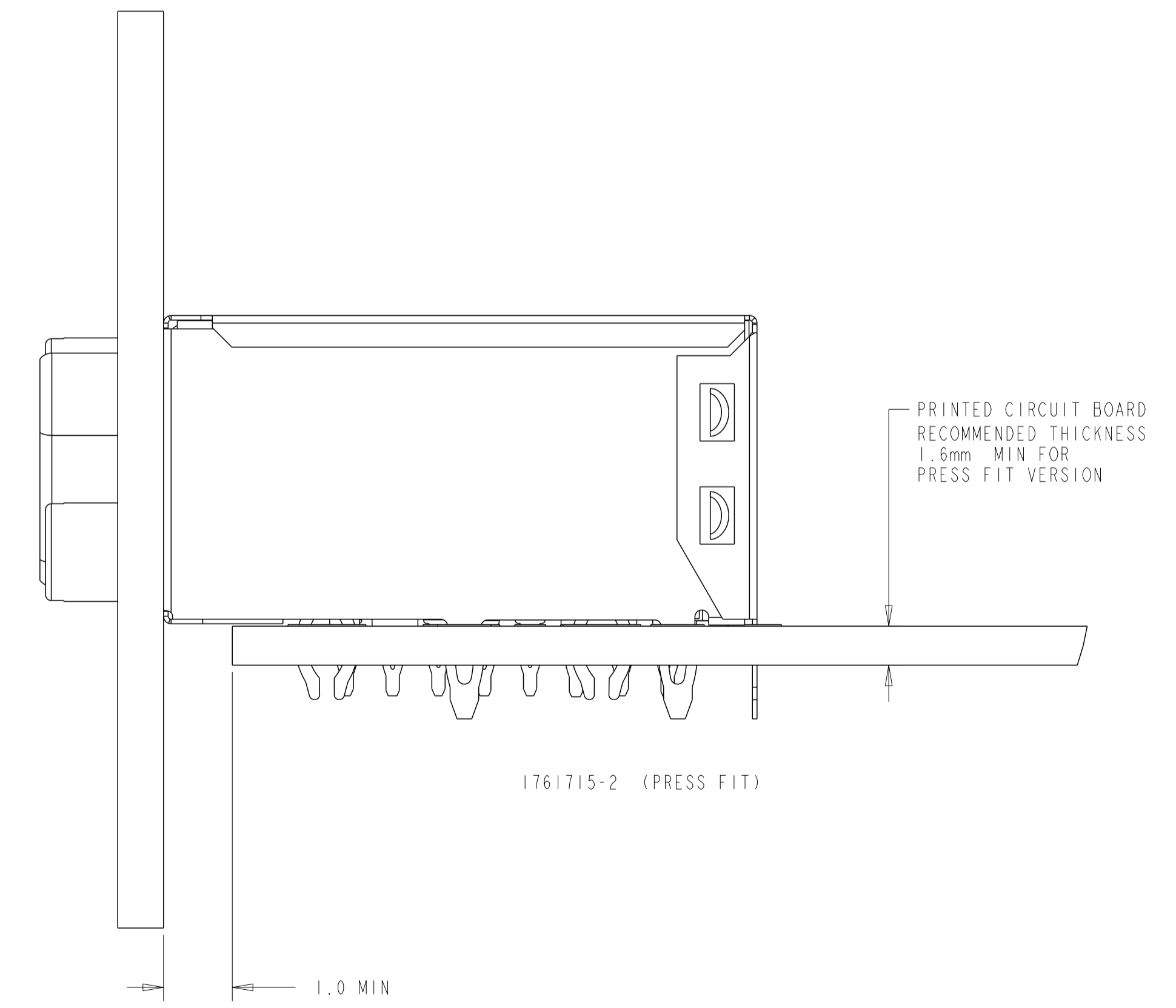

DIMENSIONS: mm 		TOLERANCES UNLESS OTHERWISE SPECIFIED: 0 PLC ± 1 PLC ±0.1 2 PLC ±0.10 3 PLC ± 4 PLC ± ANGLES ±2° FINISH -		DWN R. GRZYBOWSKI 03FEB2006 CHK M. YEOMANS 03FEB2006 APVD S. FLICKINGER 03FEB2006		Tyco Electronics Harrisburg, PA 17105-3608	
MATERIAL: SEE NOTE 1		WEIGHT: -		NAME: ASSEMBLY, RECEPTACLE, 48 POSITION, MR J21		RESTRICTED TO:	
CUSTOMER DRAWING		SCALE: 11:2		SHEET 4 OF 4		REV D1	