

# SPECIFICATION CONTROL DRAWING

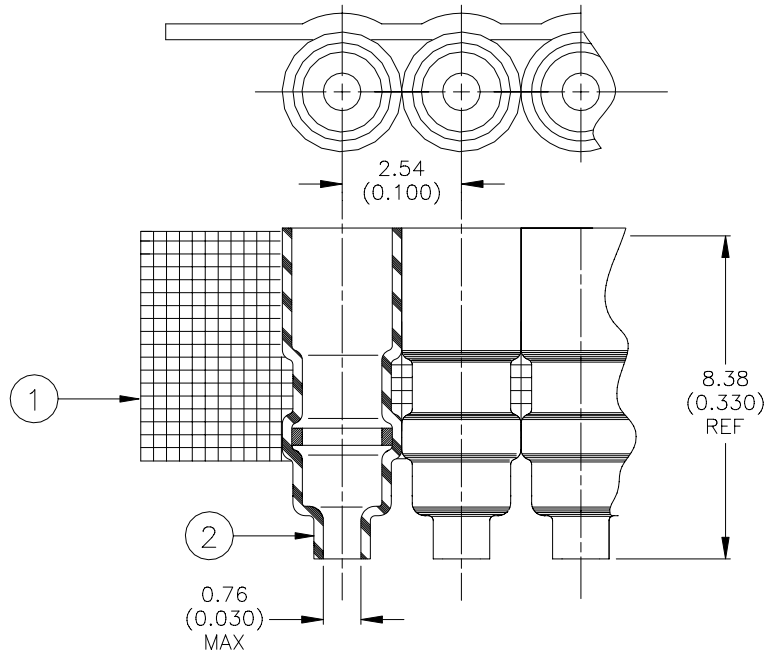

## MATERIALS

1. SOLDERSLLEEVE: D-141-07. Quantity Per Assembly: 1000
2. CARRIER STRIP: Adhesive Coated High Temperature Tape

## APPLICATION

1. This part is designed for used on Cinch "Tykon" miniature connector 255-20-30-200.
2. Sleeves are to be installed using Rayclad AD-1309 wire assembly fixture and IR-1005 infrared heater.
3. The carrier strip is to be removed upon completion of termination.

Sleeve and Terminal Assembly

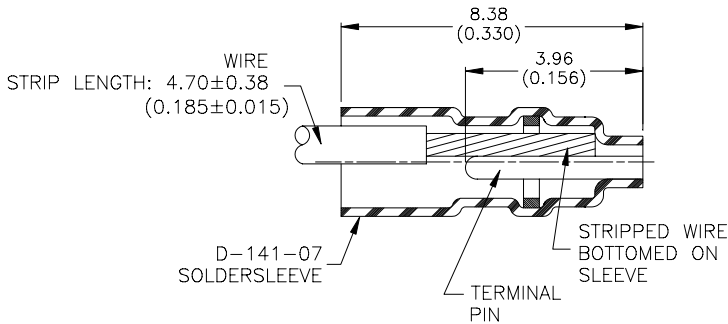

Terminal Configuration

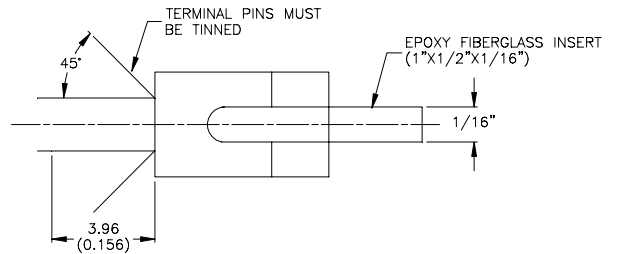

Untwist and Straighten Length

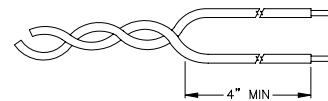

<b>tyco</b> <i>Electronics</i>	<b>Raychem</b>	Tyco Electronics Corporation 300 Constitutional Drive Menlo Park, CA 94025 USA	TITLE: <b>SOLDERPAK ASSEMBLY, CINCH "TYKON" SERIES 255-XX-30-200 ALTERNATE PINS</b>				
UNLESS OTHERWISE SPECIFIED DIMENSIONS ARE IN MILLIMETERS. INCHES DIMENSIONS ARE BETWEEN BRACKETS.			DOCUMENT NO.: <b>D-711-00</b>				
TOLERANCES: 0.00 N/A 0.0 N/A 0 N/A	ANGLES: N/A  ROUGHNESS IN MICRON	Tyco reserves the right to amend this drawing at any time. Users should evaluate the suitability of the product for their application.	DATE: <b>18-July-00</b>	DOC ISSUE:  <b>1</b>			
DRAWN BY: <b>M. FORONDA</b>	CAGE CODE: <b>06090</b>	REPLACES: <b>N/A</b>	DCR NUMBER: <b>D000403</b>	PROD. REV.: <b>D</b>	SCALE: <b>None</b>	SIZE: <b>A</b>	SHEET: <b>1 of 1</b>

If this document is printed it becomes uncontrolled. Check for the latest revision.