

PART NUMBER	REV	FIRST USED	POWER UNIT	FEED TYPE	DESCRIPTION
1852557-1	A	122500-1	LEADMAKER	POST FEED	CUTS CARRIER
1852557-2	A	565435-5	BENCH MODEL K	PRE FEED	CUTS CARRIER
1852557-3	A	354500-1	BENCH MODEL G	PRE FEED	CUTS CARRIER
1852557-6	A	122500-1	LEADMAKER	POST FEED	CONTINUOUS CARRIER
7-1852557-7	A	-	-	-	SPARE PARTS

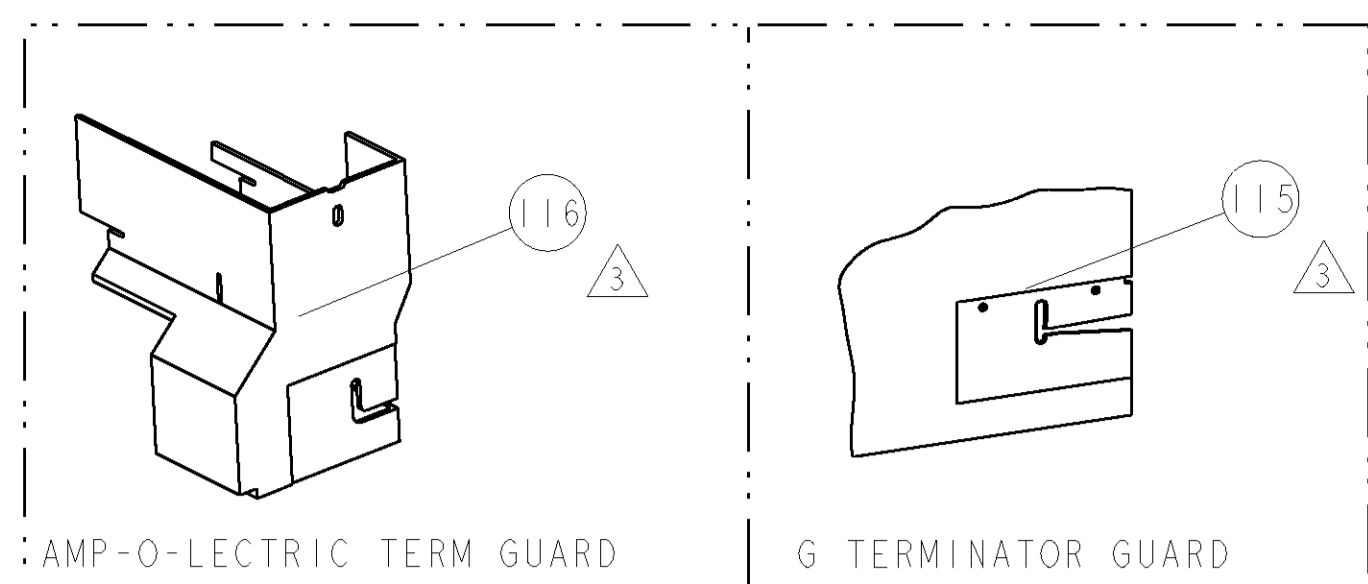

TERMINAL NAME: 040111 TK UNSEALED CONTACT RECEPTACLE			
SOCKET	PIN	TE TERMINAL - TE CRIMP SPECS	
1717366-1	-	PAD LTR	CRIMP HEIGHT
-	-	A	1.03±0.05mm [0.041±.002]
-	-	B	.94±0.05mm [0.037±.002]
-	-	C	-
-	-	D	-
-	-	CRIMP	SIZE
-	-	WIRE	1.78mm [0.070]
-	-	INSUL	1.78mm [0.070]
-	-	FEED	9.5mm
-	-	APPLICATOR INSTRUCTIONS	408-8040
-	-	SET UP GAGE	458637-1
WIRE STRIP LENGTH	4.0-4.5mm	TERM APPL SPEC	114-5217-2

- △ RECOMMENDED SPARE PARTS
- △ GREASE LIGHTLY
- △ GUARD MUST BE IN PLACE WHEN OPERATING APPLICATOR IN A BENCH MACHINE

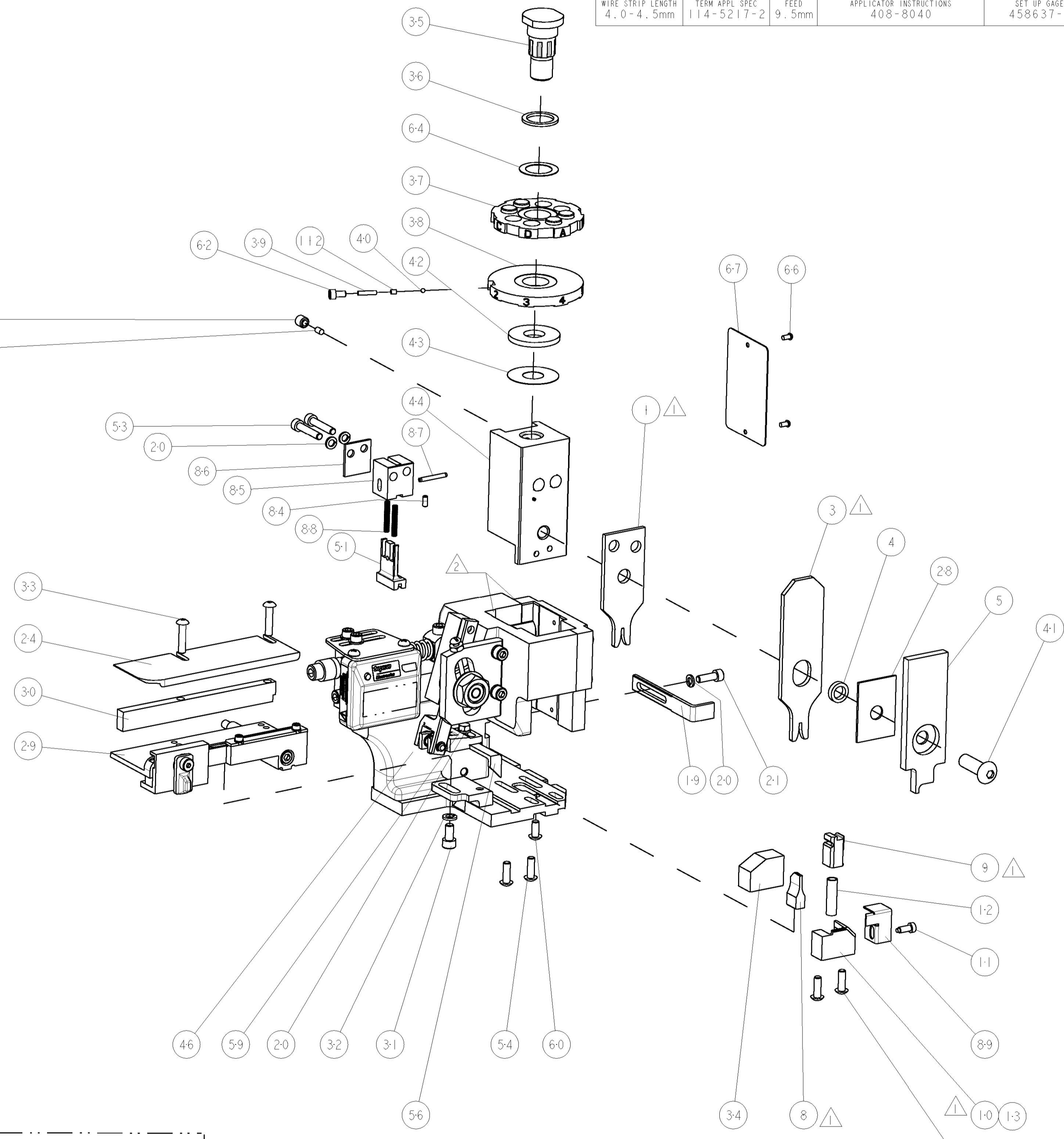
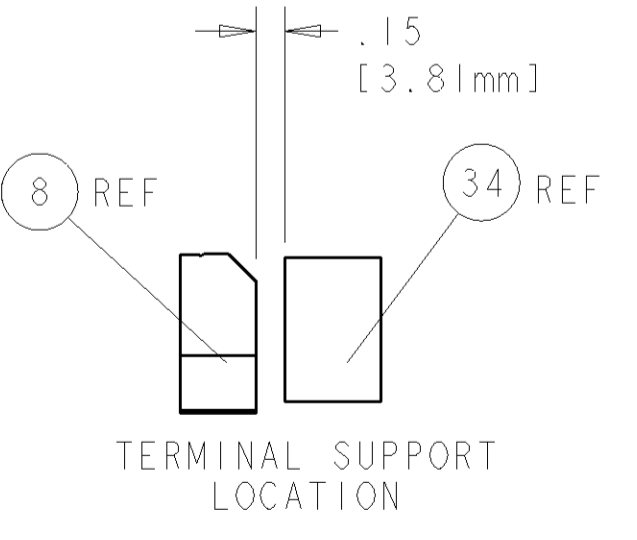
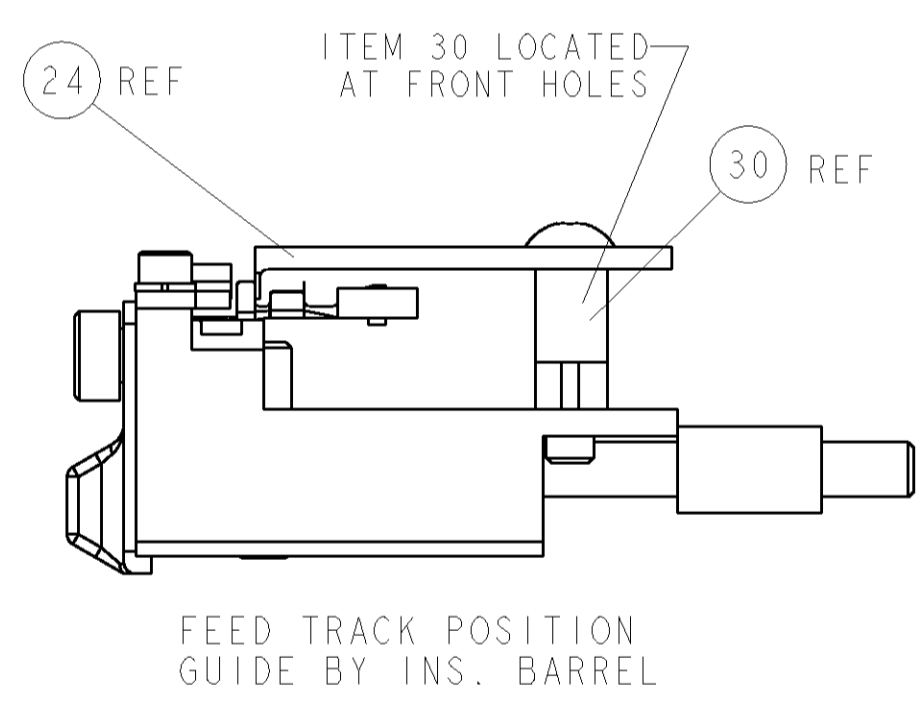
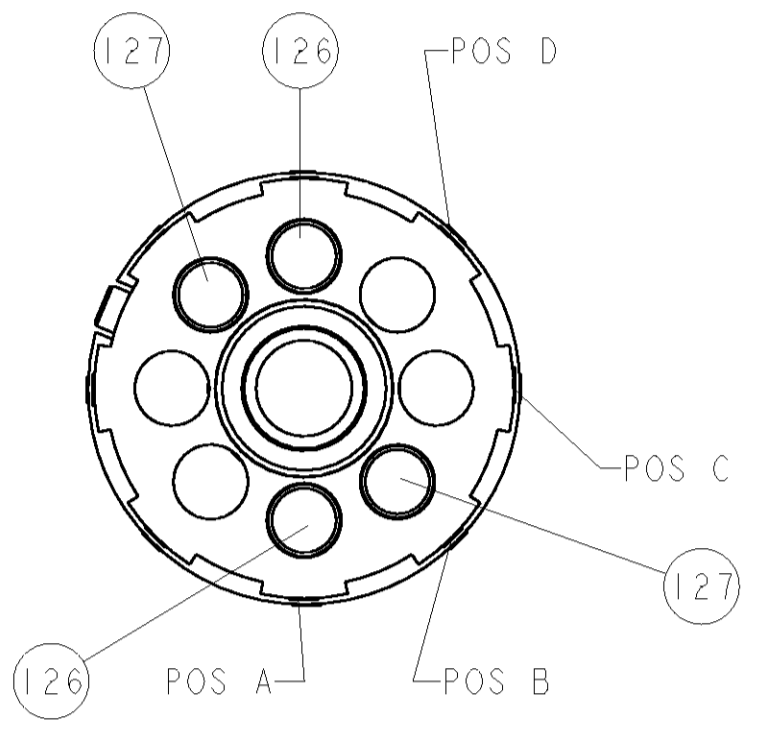

LOC	DIST	REV	DESCRIPTION	DATE	BY	APPD		
A	66		RELEASED	26SEP2007	LG	TE		
-	2	2	2	2	-	4-354779-5	PIN, WIRE DISC, .3215	127
-	2	2	2	2	-	3-354779-7	PIN, WIRE DISC, .3175	126
-	-	REF	-	-	-	455749-1	GUARD WINDOW	116
-	-	REF	-	-	-	679532-1	INSERT, GUARD	115
-	1	1	1	1	-	690603-1	SPRING ASSIST AMP-O-MATOR APPLICATOR	112
-	1	1	1	1	-	1-21002-7	SCR, BTN SKT HD CAP 6-32 X .375	91
-	1	1	1	1	-	318563-1	GUARD, FRONT CHIP	89
-	2	2	2	2	-	3-22278-0	SPRING, COMPRESSION	88
-	1	1	1	1	-	4-21028-0	PIN, SLOTTED SPRING .094 X .750	87
-	1	1	1	1	-	455053-1	PLATE, RETAINING	86
-	1	1	1	1	-	455052-1	CARRIER, HOLD DOWN	85
-	1	1	1	1	-	2-21008-1	SCR, SET, SELF LOCKING 1/4-20 X .250	84
-	1	1	1	1	-	4088040	SF APPL INST 408-8040	72
-	1	1	1	1	-	217238-1	GENERAL INSTRUCTION PKG	71
-	1	1	1	1	-	461264-1	PLATE, IDENTIFICATION	67
-	2	2	2	2	-	21017-2	SCREW, DRIVE	66
-	1	1	1	1	-	986950-1	WASHER, FLAT PRECISION	64
-	1	1	1	1	-	21009-2	SCR, SET, SELF LOCKING 1/4-20 X .250	63
-	1	1	1	1	-	23030-1	SCR, SKT HD CAP 6-32 X .25	62
-	1	1	1	1	-	22733-8	SCR, BHSC, SELF-LOCKING, 8-32 X .375	60
-	1	1	1	1	-	2-22603-0	SCR, HEX HD CAP 8-32 X .312	59
-	1	1	1	1	-	458537-2	PAWL, FEED	56
-	4	4	4	4	-	2-21002-2	SCR, BTN SKT HD CAP 8-32 X .500	54
-	2	2	2	2	-	3-21000-0	SCR, SKT HD CAP 8-32 X .875	53
-	1	1	1	1	-	8-1338389-6	HOLD DOWN, TERMINAL	51
-	-	1	-	-	-	690602-6	CAM, PRE FEED, 1 5/8	49
-	-	1	-	-	-	690602-5	CAM, PRE FEED, 1 1/8	48
-	1	1	1	1	-	690501-4	CAM, POST FEED, 1 5/8	47
-	1	1	1	1	-	459456-1	APPL. BASIC SUB ASSY (SIDE WISE MQCA)	46
-	1	1	1	1	-	690191-1	PLUG, NYLON	45
-	1	1	1	1	-	455673-1	RAM, SIDE FEED	44
-	1	1	1	1	-	690125-1	SHIM SUB-ASSY	43
-	1	1	1	1	-	1-690124-4	WASHER, RAM (.120)	42
-	1	1	1	1	-	7-21002-9	SCR, BTN SKT HD CAP 5/16-24 X 1.00	41
-	1	1	1	1	-	23241-6	BALL, STEEL	40
-	1	1	1	1	-	690170-1	SPRING, COMPRESSION	39
-	1	1	1	1	-	1-690142-3	DISC, INSULATION	38
-	1	1	1	1	-	354777-1	WIRE DISC, ASSEMBLY	37
-	1	1	1	1	-	22480-5	SPRING, COMPRESSION	36
-	1	1	1	1	-	690212-1	POST, RAM	35
-	1	1	1	1	-	690786-6	TERMINAL SUPPORT	34
-	2	2	2	2	-	2-21002-4	SCR, BTN SKT HD CAP 8-32 X .750	33
-	1	1	1	1	-	21024-5	WASHER, SPRG LOCK, REG NO 10	32
-	1	1	1	1	-	3-21000-4	SCR, SKT HD CAP 10-32 X .375	31
-	1	1	1	1	-	1-1320908-5	SPACER, STRIP GUIDE	30
-	1	1	1	1	-	1633091-1	ASSEMBLY, STRIP GUIDE	29
-	1	1	1	1	-	1-455888-0	SPACER, CRIMPER	28
-	1	1	1	1	-	1320928-5	PLATE, STRIP GUIDE	24
-	1	1	1	1	-	2-21000-7	SCR, SKT HD CAP 8-32 X .500	21
-	4	4	4	4	-	21024-4	WASHER, SPRG LOCK, REG NO 8	20
-	1	1	1	1	-	690472-9	STRIPPER	19
-	1	1	1	1	-	679625-1	SHEAR HOLDER, FRONT (NO CUT)	13
-	1	1	1	1	-	3-22280-3	SPRING, COMPRESSION	12
-	1	1	1	1	-	690461-1	STOP, SHEAR	11
-	-	1	1	1	-	690459-1	SHEAR HOLDER, FRONT	10
-	1	1	1	1	-	454276-1	FLOATING SHEAR, FRONT	9
-	1	1	1	1	-	2-1633108-6	ANVIL, COMBINATION .070	8
-	-	-	-	-	-	-	-	7
-	-	-	-	-	-	-	-	6
-	1	1	1	1	-	1-455889-4	DEPRESSOR, SHEAR	5
-	1	1	1	1	-	3-238011-5	BLOCK, CRIMPER SPACER	4
-	1	1	1	1	-	1-1633511-4	CRIMPER, INSULATION F	3
-	-	-	-	-	-	-	-	2
-	1	1	1	1	-	1-1333281-4	CRIMPER, WIRE PREMIUM	1

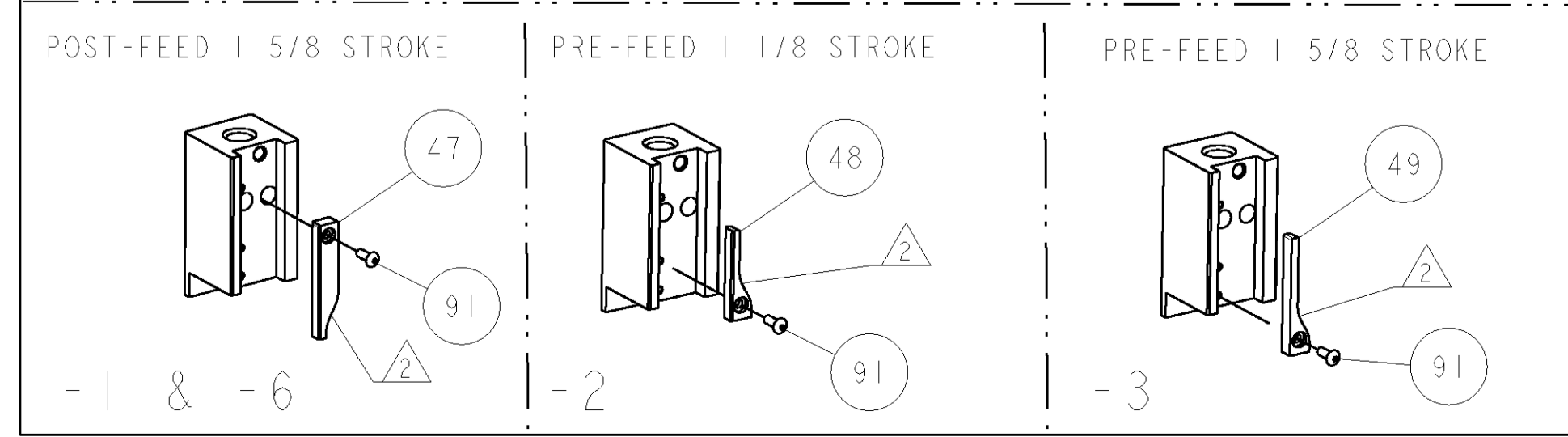

DIMENSIONS:	TOLERANCES UNLESS OTHERWISE SPECIFIED:	DATE	REV	DESCRIPTION	ITEM NO
INCHES	0 PLC ±.001 1 PLC ±.001 2 PLC ±.001 3 PLC ±.001 4 PLC ±.001	05SEP2007	05SEP2007	SIDE FEED HDM APPLICATOR	
MATERIAL	FINISH	WEIGHT	CAGE CODE	DRAWING NO	RESTRICTED TO
-	-	-	A1100779	1852557	-
CUSTOMER DRAWING		SCALE	SHEET	OF	REV
		3:5	1	1	A

CUSTOMER VIEWABLE ASSEMBLY