

1-1564546-1 AS SHOWN
1-1564546-1 wie gezeigt

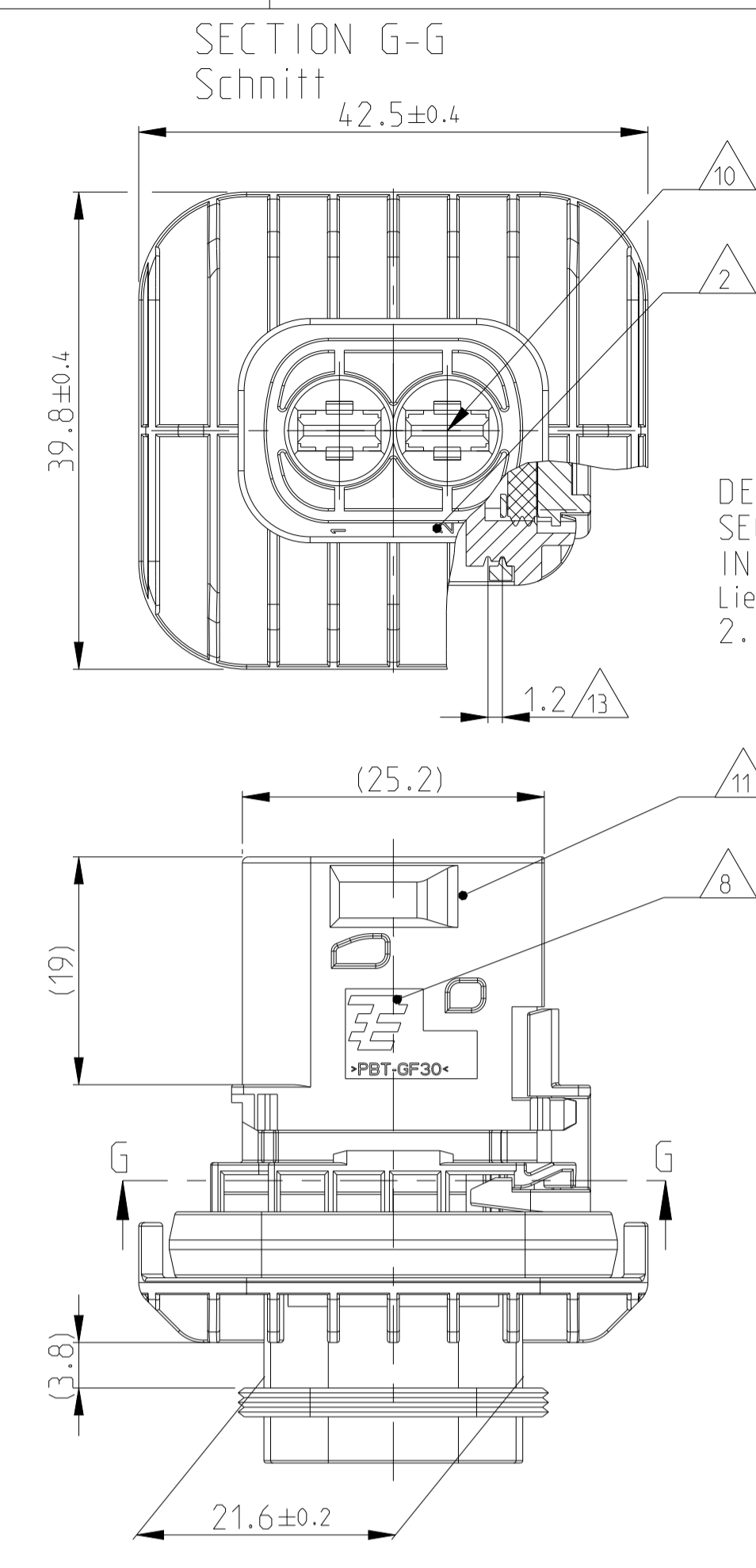

LOC	DIST	REV	DATE	BY	APPV
A1	-	J1	130C12016	MAH	GILC
		J2	27JUL2020	MAH	GILC
		J3	24AUG2021	DRK	AW
		J4	14MAR2022	NS	AW

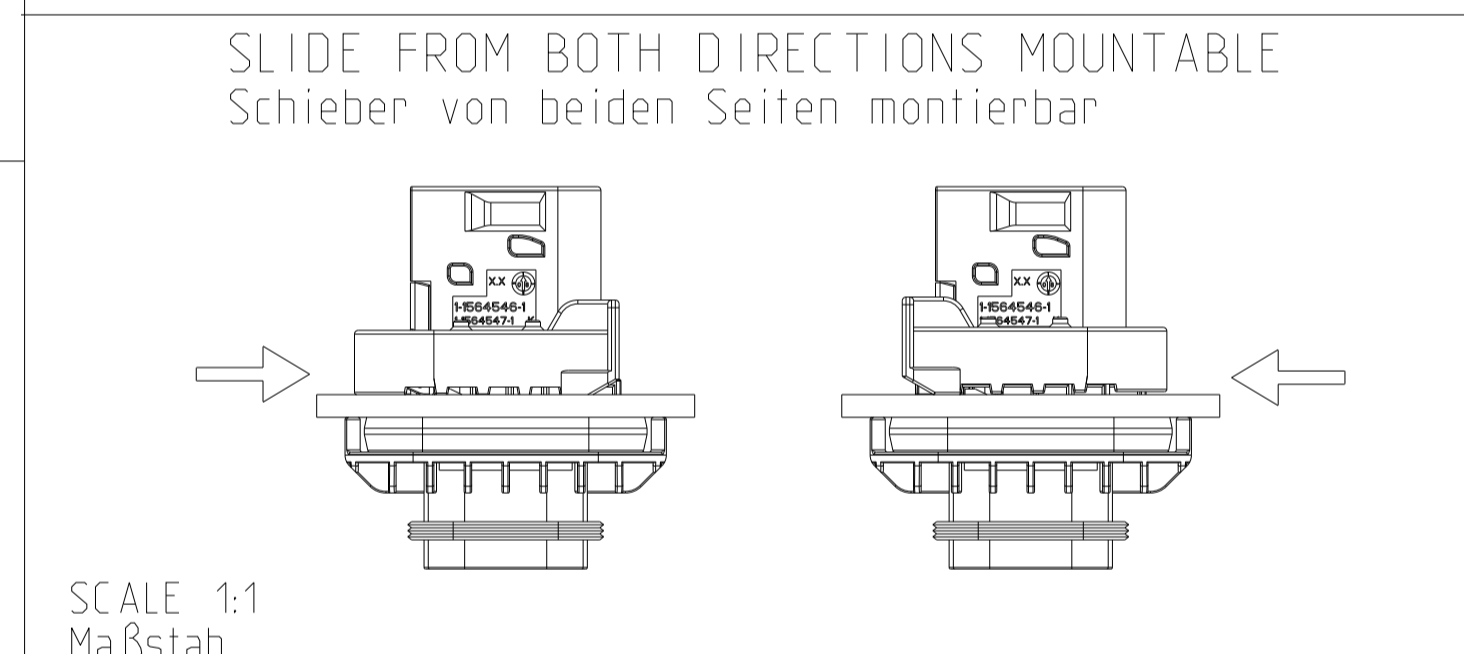
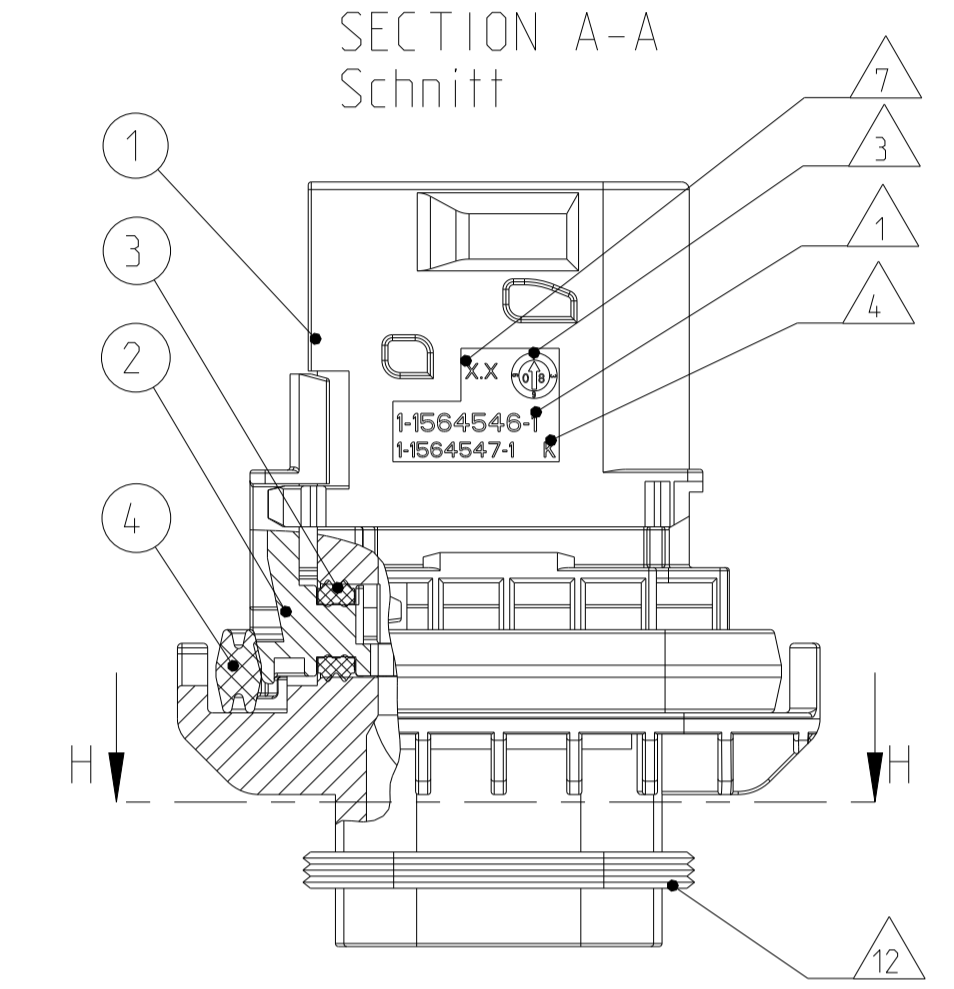
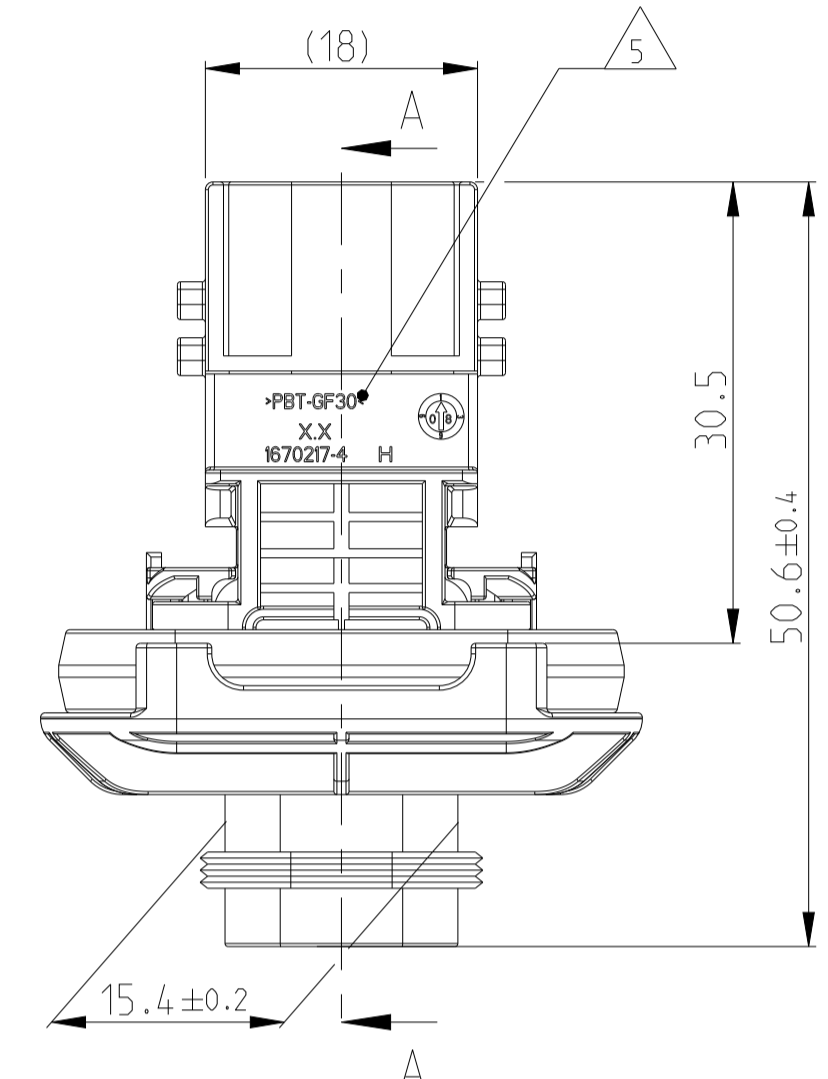

- NOTES**
Bemerkungen
- TE ORDER-NO.
TE Bestell-Nr.
 - CAVITY NUMBERING
Kammerbezeichnung
 - PRODUCTION DATE
Produktionsdatum
 - LETTER INSERT FOR THE REVISION STATUS OF THE MOULD
Schriftsatz fuer Aenderungszustand des Werkzeuges
 - MATERIAL MARKING ACCORDING TO VDA 260.
Werkstoffkennzeichnung nach VDA 260
 - BULK PACKAGING IN CORRUGATED BOX
Schuetztgut im Versandkarton
 - MOULD CAVITY MARKING
Nestmarkierung
 - TE LOGO
TE Logo
 - SUITABLE COUNTERPART SEE DRAWING 1564542
Passendes Gegenstueck siehe Zeichnung 1564542
 - CAVITIES MATED WITH TAB 5.8 x 0.8 MM (SWS)
SEE PRODUCT GROUP DRAWING TE - NO.: 1241895
MAX. WIRE SIZE: 6.0mm² FLR
ATTENTION:
SUITABLE WIRE SEALS FOR CAVITY DIAMETER 8.5mm
MUST BE USED (SAME SEALS AS FOR AMPMCP 6.3 CONTACTS.
SEE DRAWING TE - No. 1241438)
 - CONTACT CHAMBER SUITABLE FOR FLAT CONTACT 5.8 x 0.8 mm (EDS)
siehe Produktgruppenzeichnung TE - Nr.: 1241895
max. Drahtgroessenbereich: 6.0mm² FLR
Achtung:
Entsprechende Einzeldichtungen fuer Kammerdurchmesser 8.5mm
muessen verwendet werden (die gleichen Dichtungen wie fuer
AMP MCP 6.3 Kontakte, siehe Zeichnung TE - Nr.: 1241438)
 - INTERFACE ACC. DRAWING: 114-18740-1
Kragenanschluss nach Zeichnung: 114-18740-1
 - MATED WITH COVER SEE DRAWING: 1670057, 1670364
Passend zu Kappe siehe Zeichnung: 1670057, 1670364

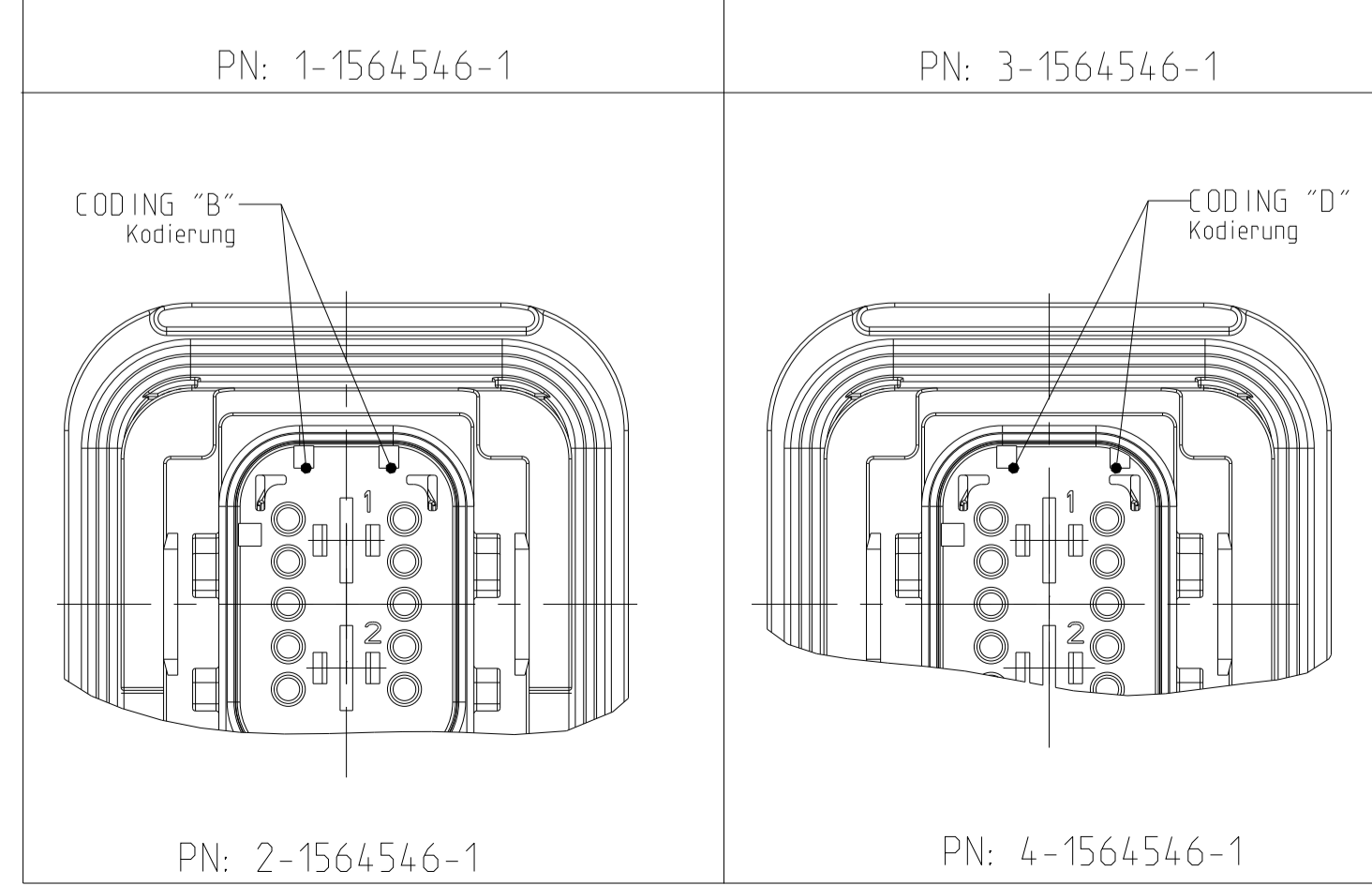
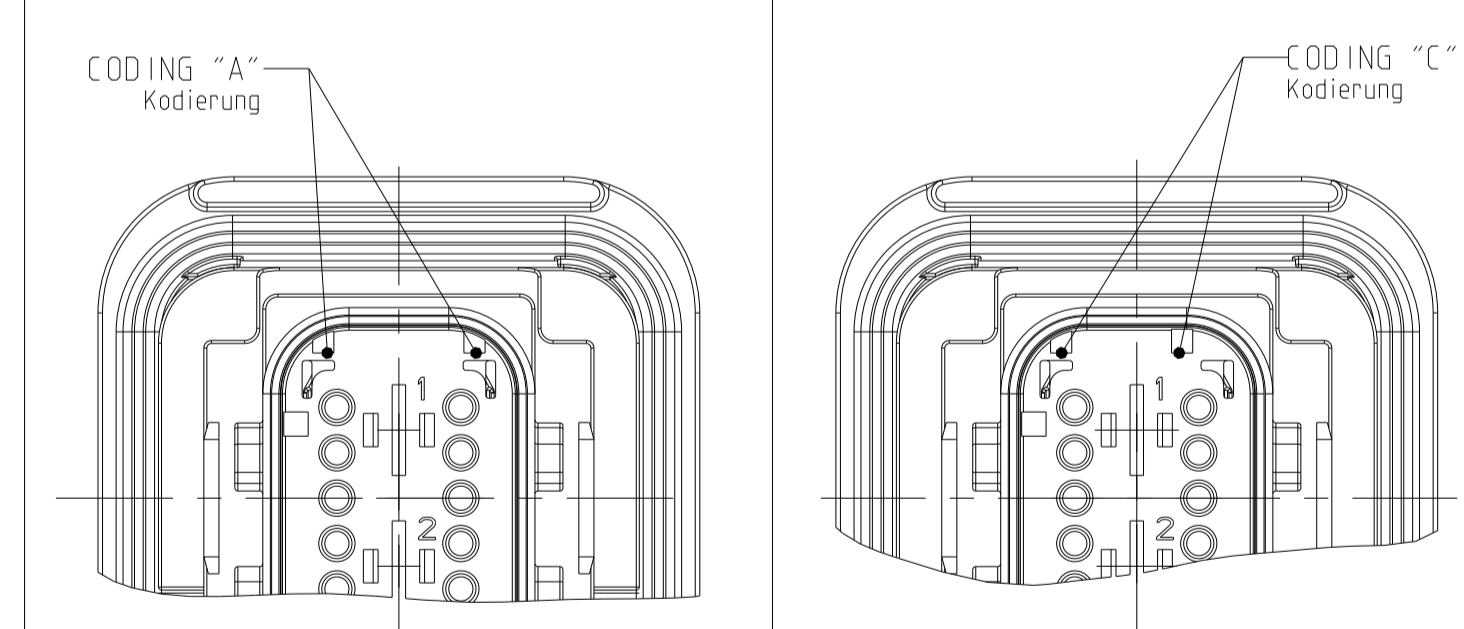
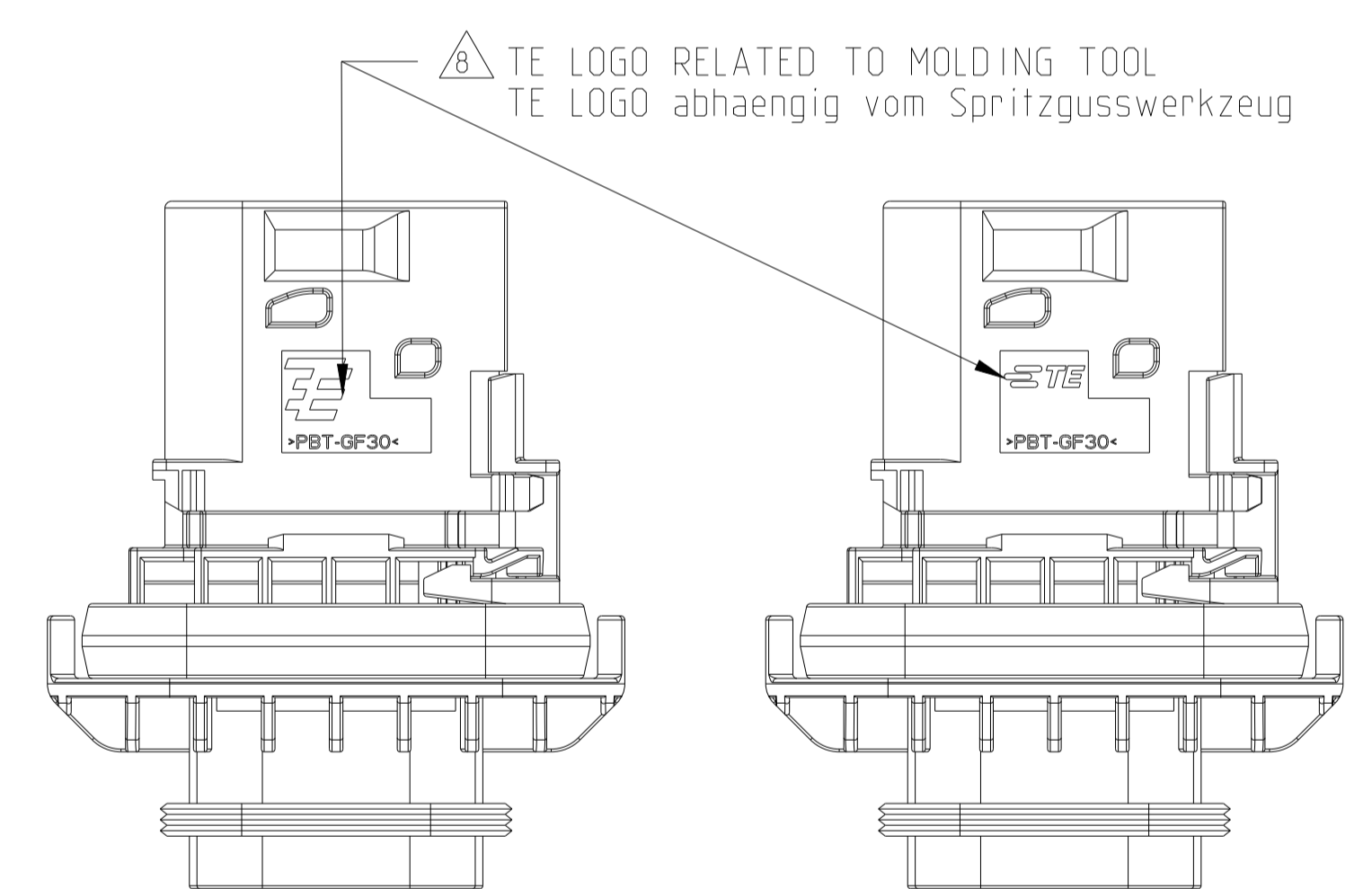
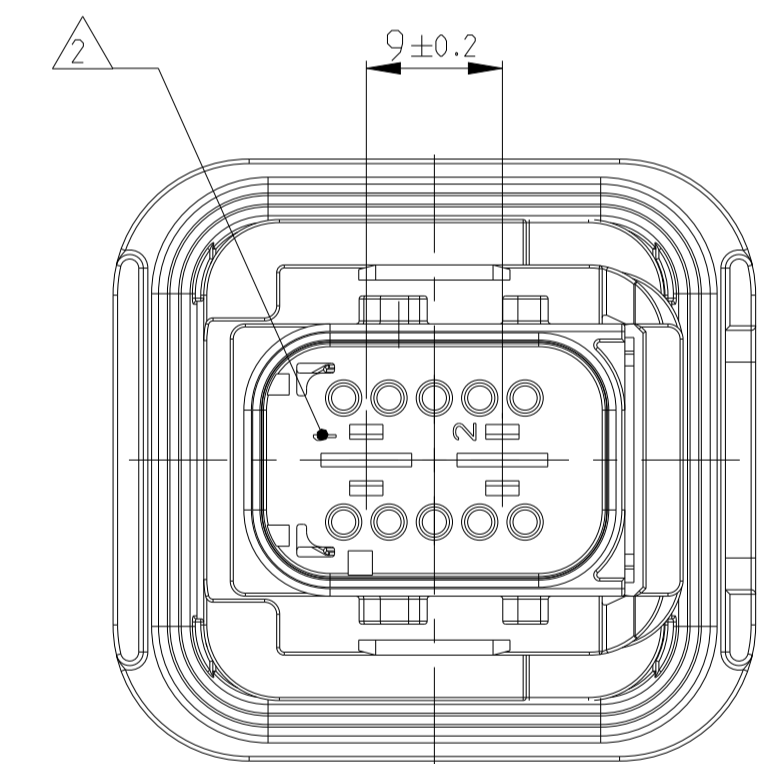
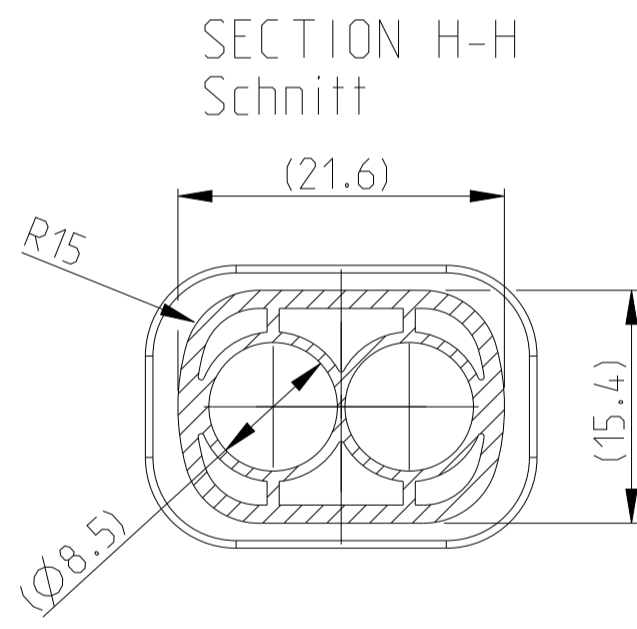

- SLIDING DISTANCE OF SECONDARY LOCKING
Verschiebeweg der zweiten Kontaktsicherung
 - MALFUNCTION CAUSED BY LAQUER IS NOT COVERED
BY TE WARRANTY
Funktionsbeeintraechtigung durch Lackieren, liegt nicht
im Einfluss und Gewaehrleistungsumfang von TE
 - SEALING SURFACE CUT-OFF
Dichtflaeche Blechsausschnitt
- SURFACE ROUGHNESS Ra MAX. 1.8µm OR LESS FOR METAL PARTS.
Werkzeugoberflaeche Ra Max. 1.8µm oder weniger fuer Metallteile
- SURFACE ROUGHNESS MIN. VDI 3400 - CLASS 24 FOR PLASTIC PARTS.
Werkzeugoberflaeche Min. VDI 3400 - Class 24 fuer Kunststoffteile.
- THE FLATNESS MUST BE WITHIN THE TOLERANCE OF THE SHEET.
THEREFORE WITHIN (±0.1MM).
Die Ebenheit muss innerhalb der Toleranz des Blechs liegen (±0.1mm).
- NO SINK MARKS, EJECTOR, DRAFT, DENTS, SCRATCHES.
RECESSES ON THE SEALING AREA ALLOWED.
Keine Einfallstellen, Auswerfer, Ausformschraegen, Delle,
Kratzer, Absaetze zulaessig.

ITEM NO	DESCRIPTION	MATERIAL	COLOUR
1	2POS. TAB MOLDING, CODE "A" Zwei-Positionen-Flachstecker, Kod. "A"	BLACK schwarz	
1	2POS. TAB MOLDING, CODE "A" Zwei-Positionen-Flachstecker, Kod. "A"	GREEN gruen	
1	2POS. TAB MOLDING, CODE "C" Zwei-Positionen-Flachstecker, Kod. "C"	GREEN gruen	
1	2POS. TAB MOLDING, CODE "D" Zwei-Positionen-Flachstecker, Kod. "D"	BLUE blau	
2	2POS. TAB MOLDING, CODE "D" Zwei-Positionen-Flachstecker, Kod. "D"	YELLOW gelb	
3	SEAL FOR SECONDARY LOCKING Dichtung fuer zweite Kontaktsicherung	WVO	
4	AXIAL SEAL 37x37 Axialdichtung 37x37	WVO	

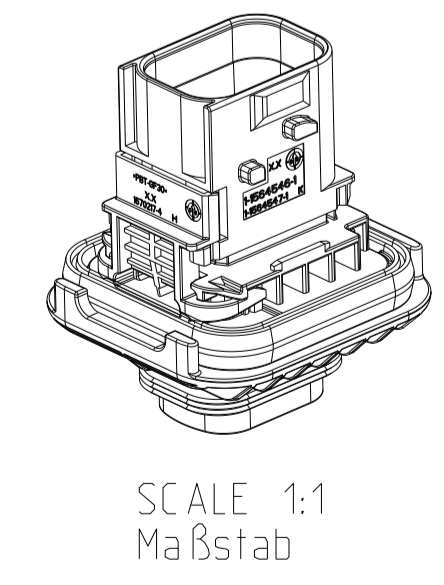
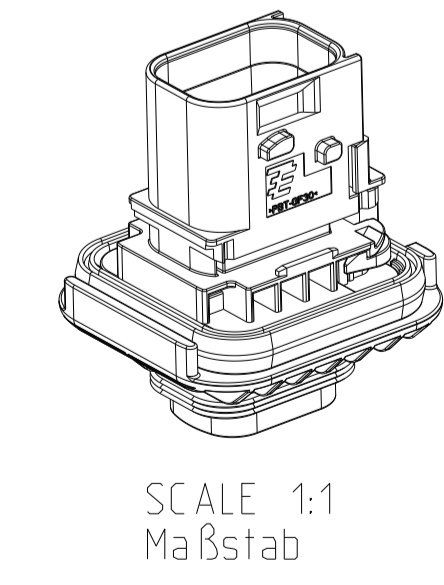

TE ORDER-NO.	REV.	NO. OF POS.	CODE	QUANTITY	ITEM NO
4-1564546-1	J	2	D	- - - 1 1 1 1 1 4	4
3-1564546-1	J	2	C	- - - 1 - 1 1 1 1 3	3
2-1564546-1	J	2	B	- 1 - - - 1 1 1 1 2	2
1-1564546-1	J	2	A	1 - - - - 1 1 1 1 1	1

TE ORDER-NO.	REV.	NO. OF POS.	CODE	QUANTITY	ITEM NO
4-1564546-1	J	2	D	- - - 1 1 1 1 1 4	4
3-1564546-1	J	2	C	- - - 1 - 1 1 1 1 3	3
2-1564546-1	J	2	B	- 1 - - - 1 1 1 1 2	2
1-1564546-1	J	2	A	1 - - - - 1 1 1 1 1	1

TE ORDER-NO.	REV.	NO. OF POS.	CODE	QUANTITY	ITEM NO
4-1564546-1	J	2	D	- - - 1 1 1 1 1 4	4
3-1564546-1	J	2	C	- - - 1 - 1 1 1 1 3	3
2-1564546-1	J	2	B	- 1 - - - 1 1 1 1 2	2
1-1564546-1	J	2	A	1 - - - - 1 1 1 1 1	1

TE ORDER-NO.	REV.	NO. OF POS.	CODE	QUANTITY	ITEM NO
4-1564546-1	J	2	D	- - - 1 1 1 1 1 4	4
3-1564546-1	J	2	C	- - - 1 - 1 1 1 1 3	3
2-1564546-1	J	2	B	- 1 - - - 1 1 1 1 2	2
1-1564546-1	J	2	A	1 - - - - 1 1 1 1 1	1

TE ORDER-NO.	REV.	NO. OF POS.	CODE	QUANTITY	ITEM NO
4-1564546-1	J	2	D	- - - 1 1 1 1 1 4	4
3-1564546-1	J	2	C	- - - 1 - 1 1 1 1 3	3
2-1564546-1	J	2	B	- 1 - - - 1 1 1 1 2	2
1-1564546-1	J	2	A	1 - - - - 1 1 1 1 1	1

TE ORDER-NO.	REV.	NO. OF POS.	CODE	QUANTITY	ITEM NO
4-1564546-1	J	2	D	- - - 1 1 1 1 1 4	4
3-1564546-1	J	2	C	- - - 1 - 1 1 1 1 3	3
2-1564546-1	J	2	B	- 1 - - - 1 1 1 1 2	2
1-1564546-1	J	2	A	1 - - - - 1 1 1 1 1	1

TE ORDER-NO.	REV.	NO. OF POS.	CODE	QUANTITY	ITEM NO
4-1564546-1	J	2	D	- - - 1 1 1 1 1 4	4
3-1564546-1	J	2	C	- - - 1 - 1 1 1 1 3	3
2-1564546-1	J	2	B	- 1 - - - 1 1 1 1 2	2
1-1564546-1	J	2	A	1 - - - - 1 1 1 1 1	1

TE ORDER-NO.	REV.	NO. OF POS.	CODE	QUANTITY	ITEM NO
4-1564546-1	J	2	D	- - - 1 1 1 1 1 4	4
3-1564546-1	J	2	C	- - - 1 - 1 1 1 1 3	3
2-1564546-1	J	2	B	- 1 - - - 1 1 1 1 2	2
1-1564546-1	J	2	A	1 - - - - 1 1 1 1 1	1

TE ORDER-NO.	REV.	NO. OF POS.	CODE	QUANTITY	ITEM NO
4-1564546-1	J	2	D	- - - 1 1 1 1 1 4	4
3-1564546-1	J	2	C	- - - 1 - 1 1 1 1 3	3
2-1564546-1	J	2	B	- 1 - - - 1 1 1 1 2	2
1-1564546-1	J	2	A	1 - - - - 1 1 1 1 1	1

TE ORDER-NO.	REV.	NO. OF POS.	CODE	QUANTITY	ITEM NO
4-1564546-1	J	2	D	- - - 1 1 1 1 1 4	4
3-1564546-1	J	2	C	- - - 1 - 1 1 1 1 3	3
2-1564546-1	J	2	B	- 1 - - - 1 1 1 1 2	2
1-1564546-1	J	2	A	1 - - - - 1 1 1 1 1	1

TE ORDER-NO.	REV.	NO. OF POS.	CODE	QUANTITY	ITEM NO
4-1564546-1	J	2	D	- - - 1 1 1 1 1 4	4
3-1564546-1	J	2	C	- - - 1 - 1 1 1 1 3	3
2-1564546-1	J	2	B	- 1 - - - 1 1 1 1 2	2
1-1564546-1	J	2	A	1 - - - - 1 1 1 1 1	1

TE ORDER-NO.	REV.	NO. OF POS.	CODE	QUANTITY	ITEM NO
4-1564546-1	J	2	D	- - - 1 1 1 1 1 4	4
3-1564546-1	J	2	C	- - - 1 - 1 1 1 1 3	3
2-1564546-1	J	2	B	- 1 - - - 1 1 1 1 2	2
1-1564546-1	J	2	A	1 - - - - 1 1 1 1 1	1

TE ORDER-NO.	REV.	NO. OF POS.	CODE	QUANTITY	ITEM NO
4-1564546-1	J	2	D	- - - 1 1 1 1 1 4	4
3-1564546-1	J	2	C	- - - 1 - 1 1 1 1 3	3
2-1564546-1	J	2	B	- 1 - - - 1 1 1 1 2	2
1-1564546-1	J	2	A	1 - - - - 1 1 1 1 1	1

TE ORDER-NO.	REV.	NO. OF POS.	CODE	QUANTITY	ITEM NO
4-1564546-1	J	2	D	- - - 1 1 1 1 1 4	4
3-1564546-1	J	2	C	- - - 1 - 1 1 1 1 3	3
2-1564546-1	J	2	B	- 1 - - - 1 1 1 1 2	2
1-1564546-1	J	2	A	1 - - - - 1 1 1 1 1	1

TE ORDER-NO.	REV.	NO. OF POS.	CODE	QUANTITY	ITEM NO
4-1564546-1	J	2	D	- - - 1 1 1 1 1 4	4
3-1564546-1	J	2	C	- - - 1 - 1 1 1 1 3	3
2-1564546-1	J	2	B	- 1 - - - 1 1 1 1 2	2
1-1564546-1	J	2	A	1 - - - - 1 1 1 1 1	1

TE ORDER-NO.	REV.	NO. OF POS.	CODE	QUANTITY	ITEM NO
4-1564546-1	J	2	D	- - - 1 1 1 1 1 4	4
3-1564546-1	J	2	C	- - - 1 - 1 1 1 1 3	3
2-1564546-1	J	2	B	- 1 - - - 1 1 1 1 2	2
1-1564546-1	J	2	A	1 - - - - 1 1 1 1 1	1

TE ORDER-NO.	REV.	NO. OF POS.	CODE	QUANTITY	ITEM NO
4-1564546-1	J	2	D	- - - 1 1 1 1 1 4	4
3-1564546-1	J	2	C	- - - 1 - 1 1 1 1 3	3
2-1564546-1	J	2	B	- 1 - - - 1 1 1 1 2	2
1-1564546-1	J	2	A	1 - - - - 1 1 1 1 1	1

TE ORDER-NO.	REV.	NO. OF POS.	CODE	QUANTITY	ITEM NO
4-1564546-1	J	2	D	- - - 1 1 1 1 1 4	4
3-1564546-1	J	2	C	- - - 1 - 1 1 1 1 3	3
2-1564546-1	J	2	B	- 1 - - - 1 1 1 1 2	2
1-1564546-1	J	2	A	1 - - - - 1 1 1 1 1	1

TE ORDER-NO.	REV.	NO. OF POS.	CODE	QUANTITY	ITEM NO
4-1564546-1	J	2	D	- - - 1 1 1 1 1 4	4
3-1564546-1	J	2	C	- - - 1 - 1 1 1 1 3	3
2-1564546-1	J	2	B	- 1 - - - 1 1 1 1 2	2
1-1564546-1	J	2	A	1 - - - - 1 1 1 1 1	1

TE ORDER-NO.	REV.	NO. OF POS.	CODE	QUANTITY	ITEM NO
4-1564546-1	J	2	D	- - - 1 1 1 1 1 4	4
3-1564546-1	J	2	C	- - - 1 - 1 1 1 1 3	3
2-1564546-1	J	2	B	- 1 - - - 1 1 1 1 2	2
1-1564546-1	J	2	A	1 - - - - 1 1 1 1 1	1

TE ORDER-NO.	REV.	NO. OF POS.	CODE	QUANTITY	ITEM NO
4-1564546-1	J	2	D	- - - 1 1 1 1 1 4	4
3-1564546-1	J	2	C	- - - 1 - 1 1 1 1 3	3
2-1564546-1	J	2	B	- 1 - - - 1 1 1 1 2	2
1-1564546-1	J	2	A	1 - - - - 1 1 1 1 1	1

TE ORDER-NO.	REV.	NO. OF POS.	CODE	QUANTITY	ITEM NO
4-1564546-1	J	2	D	- - - 1 1 1 1 1 4	4
3-1564546-1	J	2	C	- - - 1 - 1 1 1 1 3	3
2-1564546-1	J	2	B	- 1 - - - 1 1 1 1 2	2
1-1564546-1	J	2	A	1 - - - - 1 1 1 1 1	1

TE ORDER-NO.	REV.	NO. OF POS.	CODE	QUANTITY	ITEM NO
4-1564546-1	J	2	D	- - - 1 1 1 1 1 4	4
3-1564546-1	J	2	C	- - - 1 - 1 1 1 1 3	3
2-1564546-1	J	2	B	- 1 - - - 1 1 1 1 2	2
1-1564546-1	J	2	A	1 - - - - 1 1 1 1 1	1

TE ORDER-NO.	REV.	NO. OF POS.	CODE	QUANTITY	ITEM NO
4-1564546-1	J	2	D	- - - 1 1 1 1 1 4	4
3-1564546-1	J	2	C	- - - 1 - 1 1 1 1 3	3
2-1564546-1	J	2	B	- 1 - - - 1 1 1 1 2	2
1-1564546-1	J	2	A	1 - - - - 1 1 1 1 1	1

TE ORDER-NO.	REV.	NO. OF POS.	CODE	QUANTITY	ITEM NO
--------------	------	-------------	------	----------	---------