

RECOMMENDED
CABLE STRIPPING DIM'S

REV.	DATE	ECR NO.	DESCRIPTION
NC	07/15/97	XXXXXX	INITIAL RELEASE
A	05/01/07	XXXXXX	UPDATE DRAWING FORMAT
B	12/22/09	2009	UPDATE DESCRIPTION

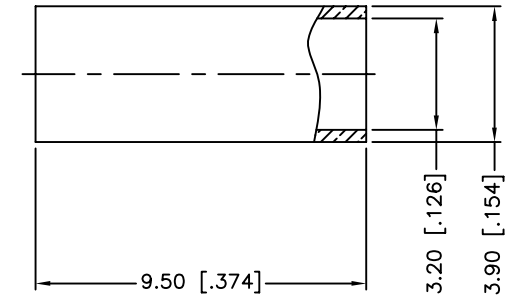
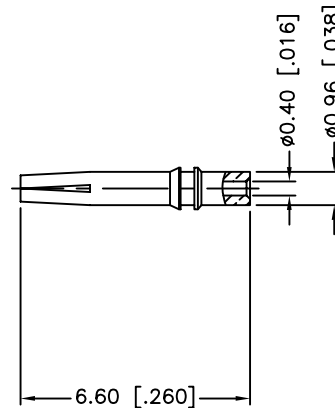
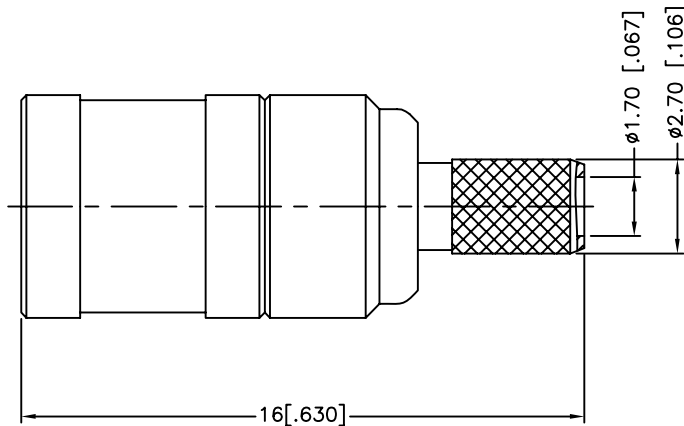
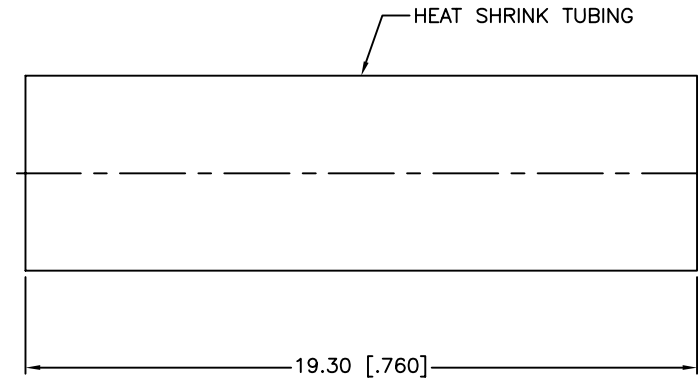

1. CRIMPED FERRULE
HEX CRIMP SIZE .128"
2. CONTACT PIN TO SOLDER

9	HEAT SHRINK TUBING			1
8	FERRULE	BRASS	GOLD	1
7	CONTACT PIN	BER. COPPER	GOLD	1
6	SHELL	BRASS	GOLD	1
5	RETAINER RING	BER. COPPER	NATURAL	1
4	BARREL	BRASS	GOLD	1
3	INSULATOR	PTFE	NATURAL	1
2	INSULATOR	PTFE	NATURAL	1
1	BODY	BRASS	GOLD	1
	DESCRIPTION	MATERIAL	FINISH	QTY

UNLESS OTHERWISE SPECIFIED DIMENSIONS ARE IN MILLIMETERS. DIMENSIONS IN [] ARE IN INCHES AND FOR CUSTOMER REFERENCE ONLY.

UNLESS OTHERWISE SPECIFIED TOLERANCES FOR MILLIMETERS ARE:
0.5 - 8mm ± 0.20mm
8 - 30mm ± 0.40mm
30 - 120mm ± 0.50mm

UNLESS OTHERWISE SPECIFIED TOLERANCES FOR INCHES ARE:
.020 - .315 = ± 0.007"
.315 - 1.180 = ± 0.015"
1.180 - 4.724 = ± 0.020"

DO NOT SCALE DRAWING

APPROVALS	DATE
DRAWN T.DENG	12/22/09
CHECKED	
ISSUED	
SHEET 1 OF 1	
CAD FILE C:/CONNEX/142186-75.DWG	

Amphenol Connex			
PART DESCRIPTION MINI 75 OHM SMB CRIMP PLUG (FOR RG-179/U, 187/U CABLE)			
PART NO.		142186-75	
DWG. NO.	142186-75.DWG	REV.	B
SIZE	A	SCALE	NA