



Technical specifications

Electrical characteristics	Module ML	Module MX
Switching voltage	12 VAC/DC max.	12 VAC/DC max.
Switching current	10 mA AC/DC max.	10 mA AC/DC max.
Dielectric strength	500 V/50 Hz	500 V/50 Hz
Durability at 5V, 1mA linear actuation	–	50x10 ⁶
Durability at 5V, 1mA tactile feel click	20x10 ⁶	50x10 ⁶
Durability at 5V, 1mA alternate action	–	0,5x10 ⁶
Durability at 5V, 1mA alternate action		50x10 ⁶
Mechanical characteristics		
Contact configuration	Single-pole contact	Single-pole contact
Action	Pressure point click	Linear, pressure point click, alternate action, ergonomic
Actuator travel	3,0–0,5 mm	4,0–0,4 mm Impuls/4,2 0,3 mm Rast/4–0,5 mm click
Pretravel	1,5 ± 0,5 mm	2 ± 0,6 mm Impuls/1,4 0,4 mm Rast/2,2 0,6 mm click
Initial force	30 cN min	25 cN min.
Actuation force	45 ± 20 cN	60 ± 20 cN linear a. Rast; 45 20 cN, ergonom. and 50 15 cN click
Pressure point force	50 ± 20 cN	55 ± 20 cN, pressure point ergonomic/60 15 cN pressure point click
Bounce time during actuation with 0,4 m/s	≤5 ms	≤5 ms
Standard lead spacing	18 mm (16 mm min.)	19,05 mm (16 mm min.)
Fastening	Fixing pins in the printed circuit board	Snap fastening in frame or fixing pins in the printed circuit board
Lighting (optional)	–	LED in red, green or yellow
Decoupling diode	–	optional
Wire jumper	optional	optional
Materials		
Insulation materials	Thermoplastics (min.UL 94 HB)	Thermoplastics (min.UL 94 HB)
Spring	Stainless steel	Stainless steel
Contacts	High-quality gold alloy	High-quality gold alloy
Other Characteristics		
Protection class	IP 40	IP 40
Operating temperature	–10 °C to +70 °C	–10 °C to +70 °C
Storage temperature	–40 °C to +70 °C	–40 °C to +70 °C
Humidity (without condensation)	5 % to 95 %	5 % to 95 %
Soldering capability	see soldering specifications	see soldering specifications

For detailed information and the layout of the details described above, please do not hesitate to ask for our technical specifications and drawing.



Keymodule MX

Features

The constructive design of the key and the design of the associated keycaps fulfil the ergonomic requirements for data input workstations. Long operating life with gold crosspoint contact and high reliability with quick actuation. Optionally with integrated colour LED decoupling diode or wire bridge. 4 mm actuation travel.

Size of keycap	1x2	1x3	1x8
	1x2,25 1x2,75		
Type of keycap	8 mm/Cyln	8 mm/Cyln	8 mm/Cyln
„A“ (in mm)	23,8	38,1	133,35
Part-No. (without Pins)	G99-0224	G99-0225	G99-0226
Part-No. (with Pins)	G99-0742	G99-0743	G99-0744

View of keymodule

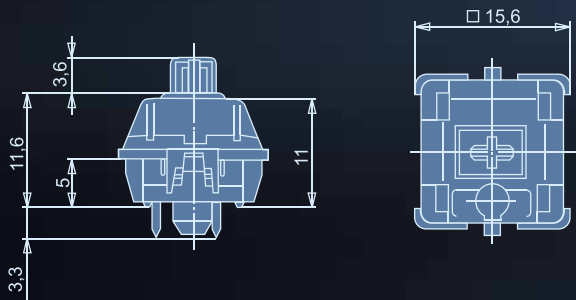

Keyswitch assembly



Drilling patterns

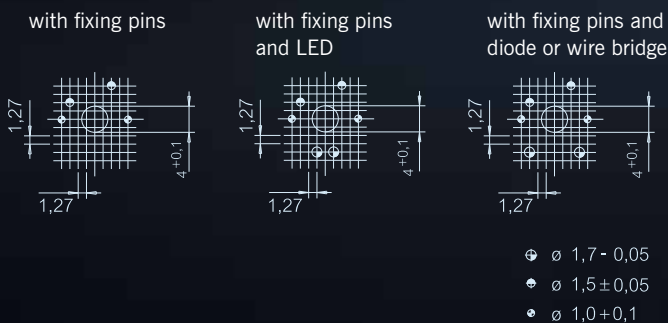

Locking unit

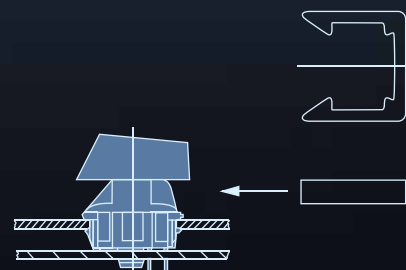

Force/travel diagram

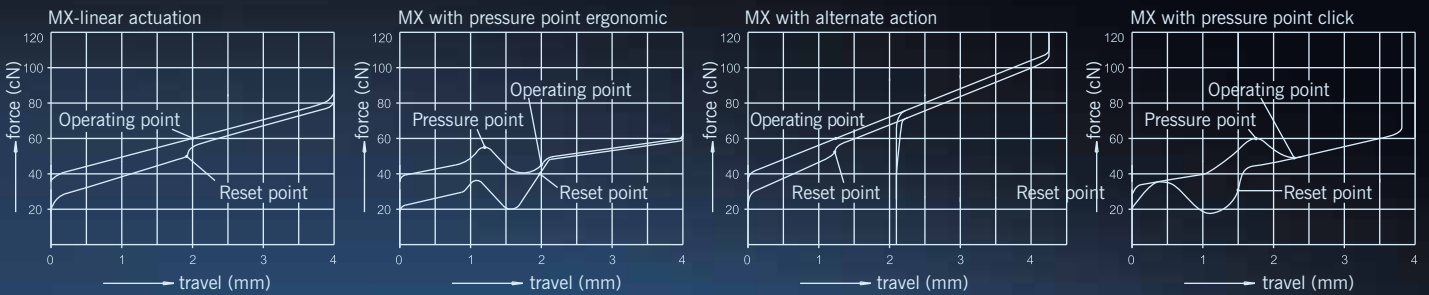

Multiple key mechanical

without frame

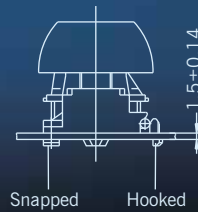
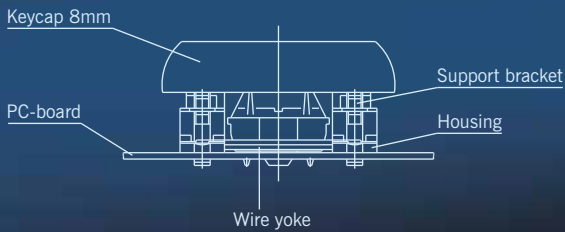

Drilling pattern

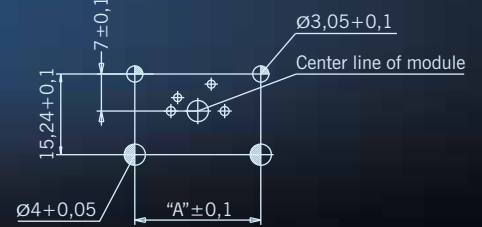

with frame

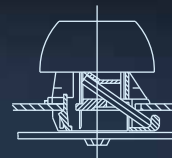
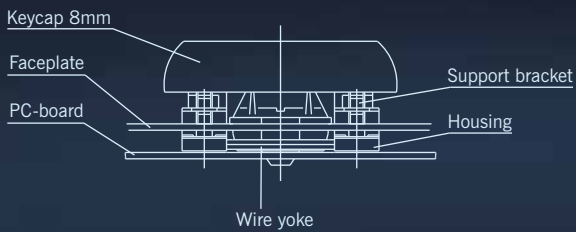

Cutout of frame for keycaps sizes
1x2, 1x2,25, 1x2,75

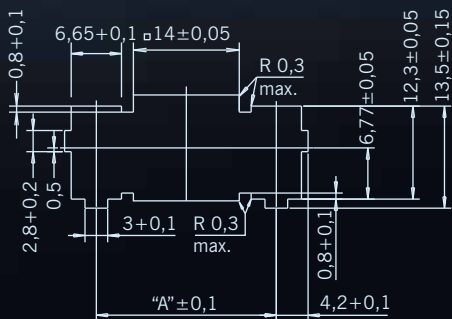

Cutout of frame for keycaps sizes
1x3, 1x7, 1x8, 1x9, 1x10

