

Extraction Tool 1583190-1

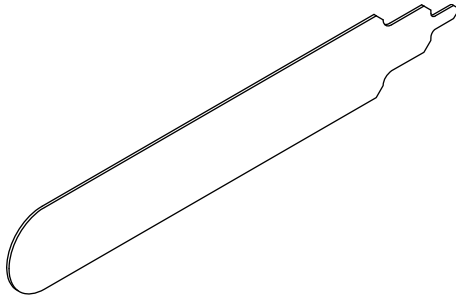

Figure 1

1. INTRODUCTION

Extraction Tool 1583190-1 is designed to extract Mini Power Drawer Contacts 1489128-[] from Mini Power Drawer Vertical Receptacles and Plug Connectors 1489701-1.

Reason for revision is provided in Section 6, REVISION SUMMARY.

2. DESCRIPTION

The extraction tool, made of stainless steel, features a handle with an extraction tip. The tip will enter the contact cavity of the connector and depress the locking latch on the contact. This will enable the contact to be pulled out from the rear of the connector. See Figure 1.

3. EXTRACTION PROCEDURE (Figure 2)

1. Position tool in front of the connector with tip entering the mating side of the connector.

2. Push the tool into the contact cavity on the locking lance side of the connector.
3. Extraction tool should bottom on the outside shoulders of the tool.
4. With tool in place, gently pull on the wire of the contact and remove.
5. Repeat this procedure for any additional contacts that may need removed.

4. REPAIR AND REPLACEMENT

Use Extraction Tool 1583190-1 to remove individual contacts from housings for replacement or for relocation to another housing cavity. Damaged or worn contacts may be replaced provided there is sufficient slack, after re-stripping the wire, to insert the new contact.



DO NOT re-use damaged or worn contacts. Instead, replace them with new contacts and discard the old ones.

5. TOOL REORDERING INFORMATION

Extraction Tool 1583190-1 is not repairable and should be replaced when it is worn or damaged.

Additional tools can be purchased from:

CUSTOMER SERVICE (038-035)
 TYCO ELECTRONICS CORPORATION
 PO BOX 3608
 HARRISBURG PA 17105-3608

6. REVISION SUMMARY

- New logo

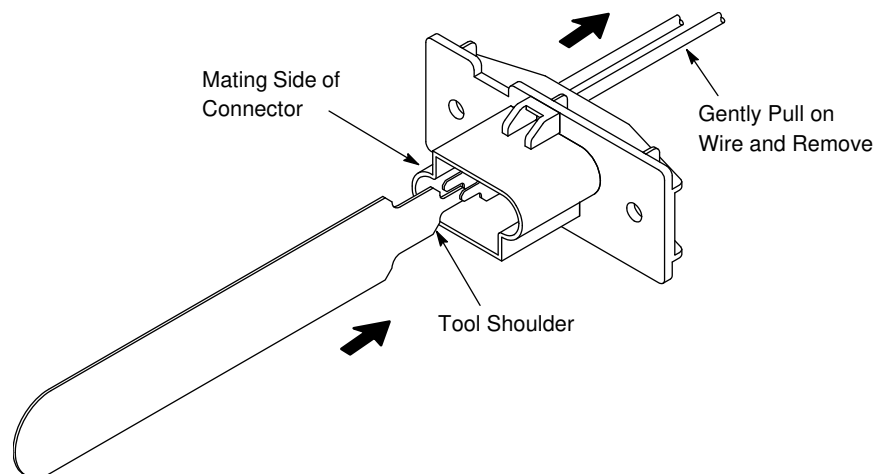

Figure 2