

PART NUMBER:  
10110224-101LF

# 72 Pair Cable Connector

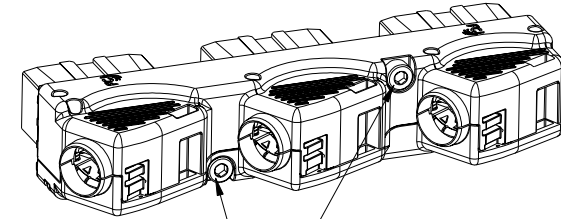
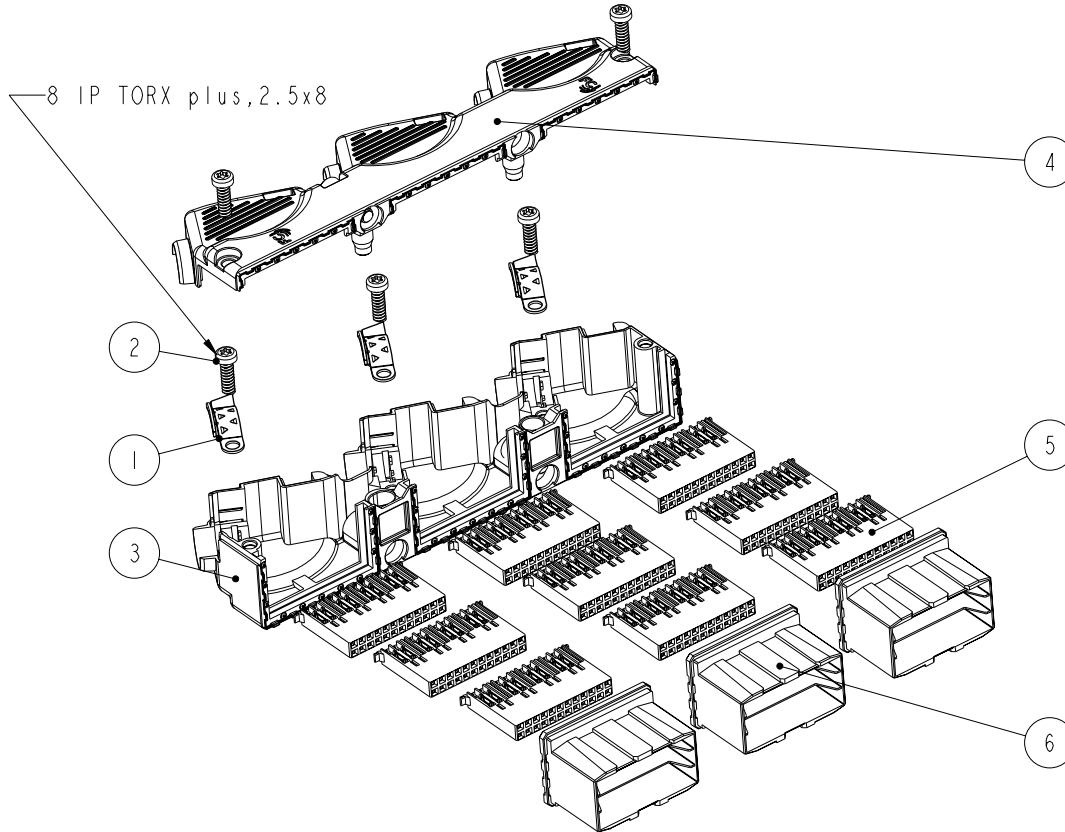

Hexagon M2.5x3  
(Pre-assembled in cover-parts)

6	SHROUD	3
5	TERMINAL BLOCK ASSEMBLY	9
4	SUB-ASS'Y TOP-COVER	1
3	SUB-ASS'Y BOTTOM-COVER	1
2	CONNECTOR SELF TAPPING SCREW	5
1	CLAMP	3
INDEX NO.	TITLE I	QTY



Copyright FCI.

rev	ecn no	dr	date
A	N10-0022	R.B	12/08/2009
-	-	-	-
-	-	-	-
-	-	-	-

www.fciconnect.com		surface ISO 1302	tolerance std ISO 406 / ISO 1101	projection mm	mm	
		TOLERANCES UNLESS OTHERWISE SPECIFIED		mm		
Dr	Rick Bian	12/08/2009	ANGULAR	0.x	±-	size
Eng	Rick Bian	12/08/2009	LINEAR	0.xx	±-	A3
Chr	Daniel Tao	12/08/2009	0° ±°	0.xxx	±-	ECN
Appr	Joseph Hsia	12/08/2009	Product family	Metral	Spec ref	
Title			ASSEMBLY KIT		dwg no	10110224
Title			METRAL HDXS CABLE CONNECTOR		Rev.	A
catalog no			-		CUSTOMER	sheet 1 of 4

REV F - 2006-04-17

PART NUMBER:  
10110224-101LF

# TOP CABLING

A

B

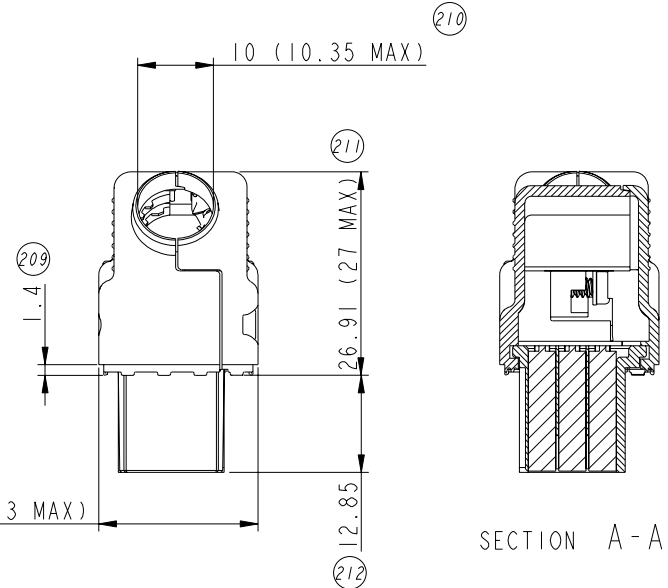
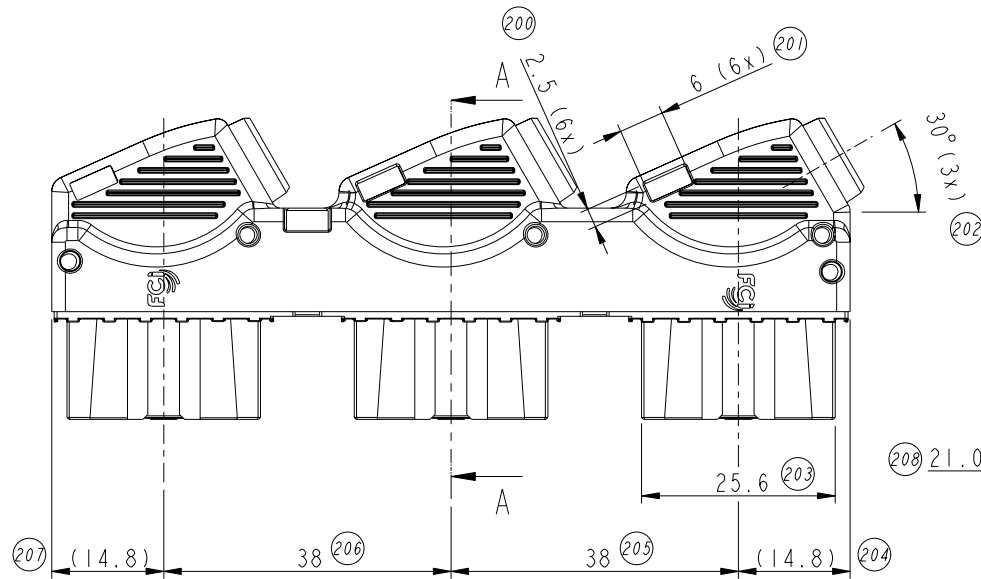

SCALE 3:2

C

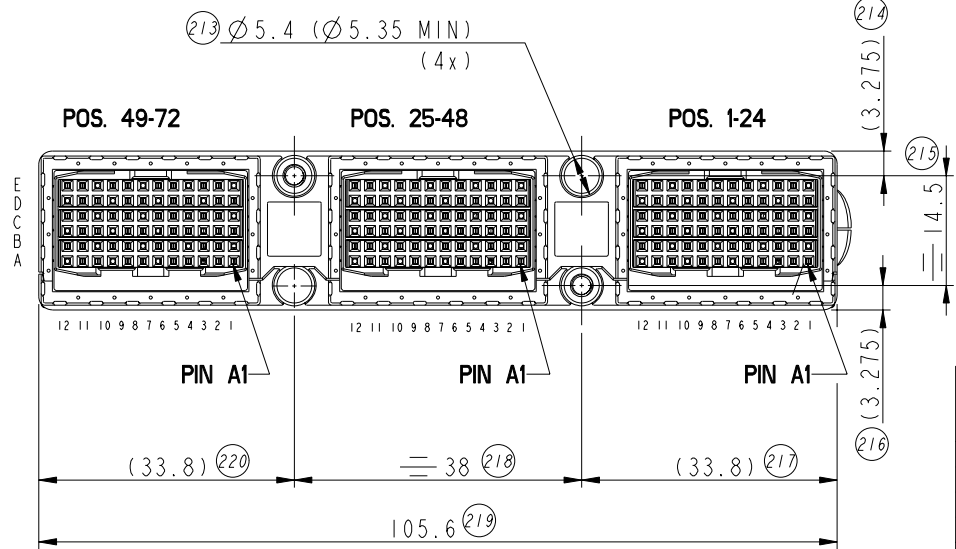

Copyright FCI.

D

www.fciconnect.com		surface ISO 1302	tolerance std ISO 406 / ISO 1101	projection 	mm
TOLERANCES UNLESS OTHERWISE SPECIFIED					
Dr	Rick Bian	12/08/2009	ANGULAR	0.x ±	size A3
Eng	Rick Bian	12/08/2009	LINEAR	0.xx ±	Scale 3:2
Chr	Daniel Tao	12/08/2009	0° ±	0.xxx ±	ECN
Appr	Joseph Hsia	12/08/2009	Product family	Metral	Spec ref
			Title ASSEMBLY KIT		Rev. A
			Title METRAL HDXS CABLE CONNECTOR		
			dwg no	10110224	
			catalog no	CUSTOMER	sheet 2 of 4

Highest balloon number: 220  
Removed balloon numbers:

REV F - 2006-04-17

PART NUMBER:  
10110224-101LF

# BOTTOM CABLING

A

B

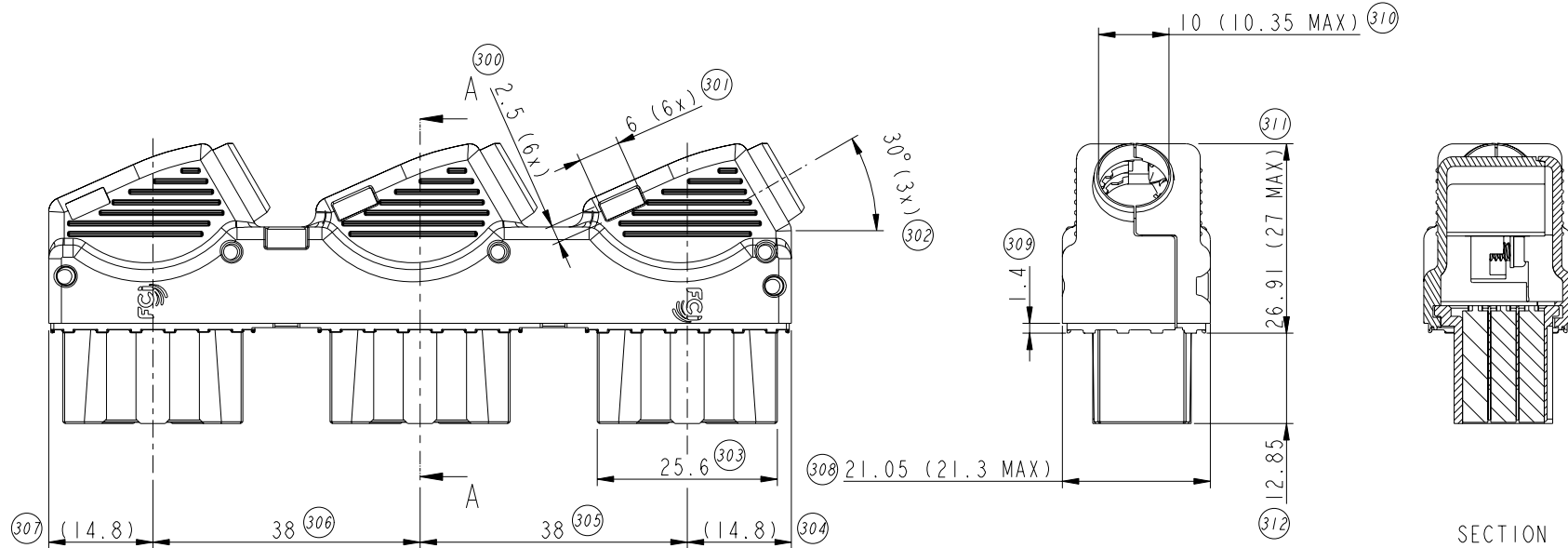

A

B

SECTION A-A

C

D

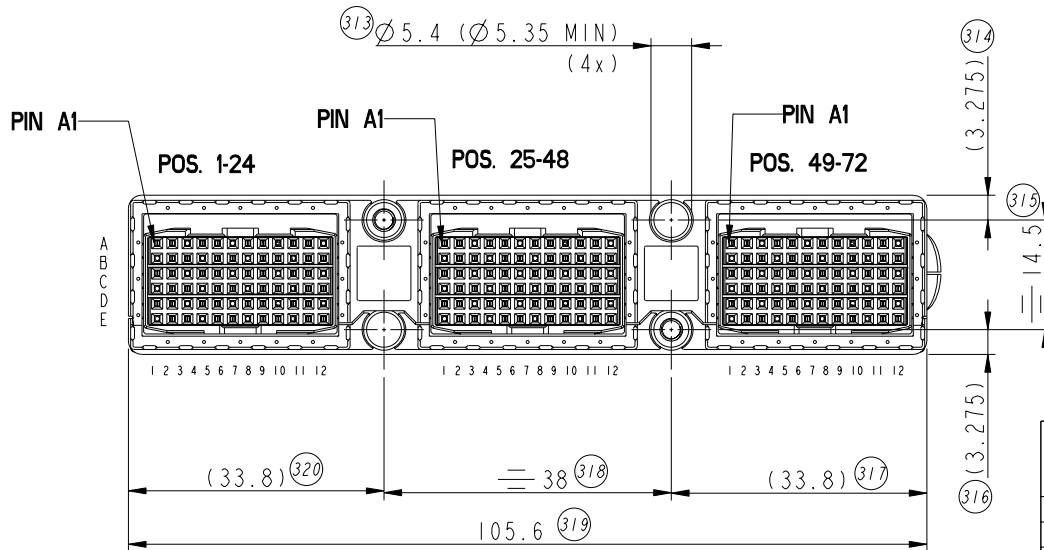

SCALE 3:2

C

D



Copyright FCI.

www.fciconnect.com		surface ISO 1302	tolerance std ISO 406 / ISO 1101	projection mm	
		TOLERANCES UNLESS OTHERWISE SPECIFIED			
Dr	Rick Bian	12/08/2009	ANGULAR	0.x	±-
Eng	Rick Bian	12/08/2009	LINEAR	0.xx	±-
Chr	Daniel Tao	12/08/2009	0° ±°	0.xxx	±-
Appr	Joseph Hsia	12/08/2009	Product family	Metral	Spec ref
		Title		ASSEMBLY KIT	
		Title		METRAL HDXS CABLE CONNECTOR	
		catalog no		-	
		dwg no		10110224	
		Rev.		A	
		CUSTOMER		sheet 3 of 4	

Highest balloon number: 320  
Removed balloon numbers:

REV F - 2006-04-17

PART NUMBER:  
10110224-101LF

# Cable diameter and cable clamp position

Cable Clamp at pos.A  
for cable diameters  
Ø 7mm-Ø 8mm

Cable Clamp at pos.B  
for cable diameters  
Ø 9mm-Ø 10mm

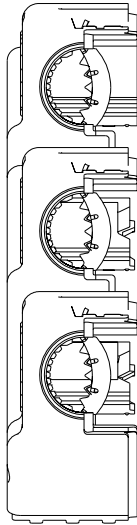

SCALE 3:2

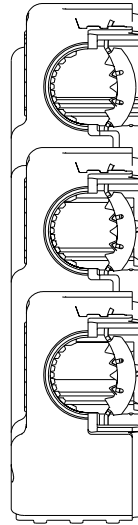

SCALE 3:2

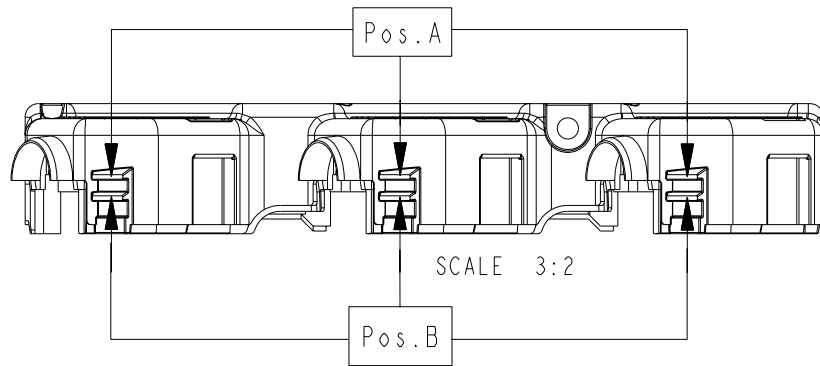

SCALE 3:2

## NOTES:

1. Product specification: GS-12-485.
2. Application specification: GS-20-091.
3. Packaging specification: GS-14-1265.
4. Performance level: Telcorida CO.
5. Flammability classification: UL94 V-0.
6. RoHS Compliant.
7. Wire size: AWG24

www.fciconnect.com		surface ISO 1302	tolerance std ISO 406 / ISO 1101	projection mm	
		TOLERANCES UNLESS OTHERWISE SPECIFIED			
Dr	Rick Bian	12/08/2009	ANGULAR	0.X	±-
Eng	Rick Bian	12/08/2009	LINEAR	0.XX	±-
Chr	Daniel Tao	12/08/2009	0° ±°	0.XXX	±-
Appr	Joseph Hsia	12/08/2009	Product family	Metral	Spec ref
	title ASSEMBLY KIT		dwg no 10110224		Rev. A
	METRAL HDXS CABLE CONNECTOR		CUSTOMER		sheet 4 of 4
	catalog no				

Copyright FCI.