

STANDARD SPECIFICATIONS	
PARAMETERS	MAX (Unless otherwise noted)
Frequency Range	32.768 kHz
Frequency Tolerance @ 25°C	±20 PPM
Frequency Stability, ref 25°C (Temperature Coefficient)	-0.04 PPM / (Δ°C) ²
Temperature Range	
Turnover (T ₀)	+20°C ~ +30°C
Operating (T _{OPR})	(See options below)
Storage (T _{STG})	-40°C ~ +85°C
Equivalent Series Resistance (R _S) KT15	50 kΩ
Load Capacitance (C _L)	(See options below)
Insulation Resistance @ 100V _{DC}	500MΩ Min
Drive Level	1.0μW
Aging per year (@ 25°C)	±3 PPM
Wave Soldering Temp / Time	300°C / 5 Sec (leads only)
Moisture Sensitivity Level (MSL) per J-STD-033	1
Termination Finish	SnCu
Lead (Pb) Free	Yes
RoHS Compliant	Yes, no exemptions
REACH Compliance	Yes

DIMENSIONS / MECHANICAL SPECIFICATIONS
<p>Dimensions (mm)</p> <p>KT15</p> 
<p>Note: Dimensional drawing is for reference to critical specifications defined by size measurements. Certain non-critical visual attributes, such as side castellations, etc. may vary.</p>

Temperature Coefficient

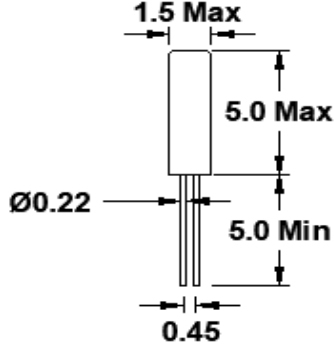

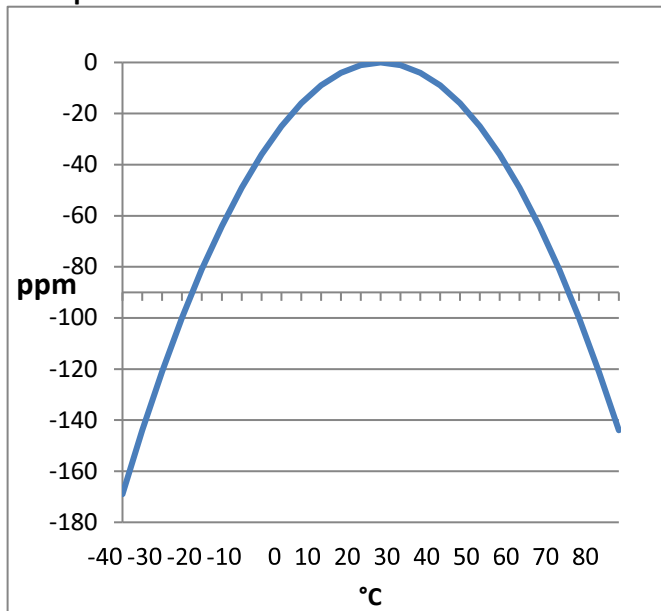

Available Options & Part Identification for FKT15

Sample PN: FKT15EIHM0.032768

F	KT15	E	I	H	M	0.032768	
<u>Fox</u>	<u>Model Number</u> KT15	<u>Tolerance</u> E = ±20ppm	<u>Stability</u> I = -0.04 PPM/ (Δ°C) ²	<u>Load Capacitance</u> B = 6pF H = 12.5pF	<u>Operating Temperature</u> C = 0 ~ +70°C D = -10 ~ +60°C Q = -20 ~ +60°C M = -40 ~ +85°C	<u>Frequency (MHz)</u>	<u>Values Added Options</u> Blank = Bulk

Reliability Test Conditions

Please contact Abracon Quality Assurance department

Crystal Unit Handling Precautions

1) Mounting Precautions

- Structure-Cylinder crystals are hermetically sealed using glass to metal seals (see figs 1 and 2)

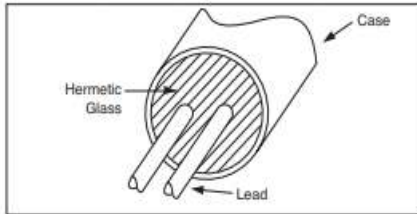

Figure 1

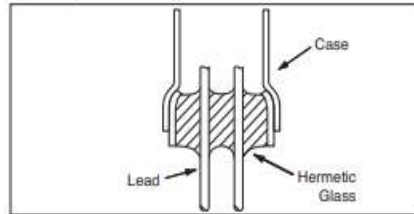

Figure 2

- Unbending the lead

(1) DO NOT pull the lead excessively if unbending a lead or removing a crystal unit. The excessive force may crack the glass and reduce the degree of vacuum. This may eventually result in deterioration of the characteristics and may also break the crystal chip (see Figure 3).

(2) Unbend the lead by pressing on the bent part from both the upper and lower sides while holding the bottom of lead tightly (see Figure 4).

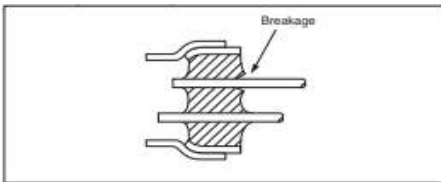

Figure 3

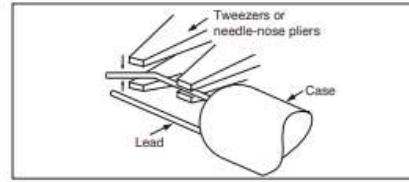

Figure 4

- Bending the lead

(1) Bend the lead so that the lead will remain straight for more than 0.5mm from the case when soldering a crystal unit after bending. If not, the glass may be cracked (see Figures 5 and 6).

(2) Always leave a length greater than 2.0mm when bending a lead after soldering (see Figure 7)

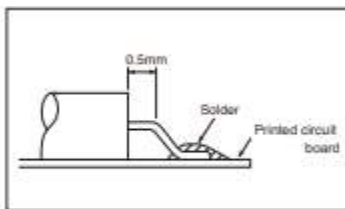

Figure 5

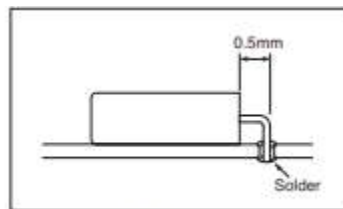

Figure 6

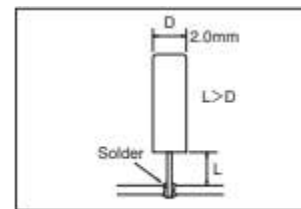

Figure 7

Soldering directly to the case will reduce the degree of vacuum and may result in deterioration of the characteristics and may break the crystal chip.

Make the length from the case to the printed circuit board (L) longer than the case diameter (D) so that the lead wire will not be pulled in case the crystal unit falls over.

2) Soldering

The soldering position must be at the lead wire more than 1.0mm away from the glass seal. Excessive heating time at high temperature may result in deterioration of the characteristics and may break the crystal unit. If crystal unit is unavoidably heated, heat the lead part at 300°C or lower for 5 seconds or less and please make sure to keep the case below 150°C.

3) Cleaning

Since a small, thin crystal chip is used for tuning fork crystal units and the frequency approximates that of an ultrasonic cleaner, the crystal chip may break easily. Therefore, DO NOT perform ultrasonic cleaning.