

Sealed Sensor Connector (SSC)
NOTE

All numerical values are in metric units [with U.S. customary units in brackets]. Dimensions are in millimeters [and inches]. Unless otherwise specified, dimensions have a tolerance of ± 0.13 [± 0.005] and angles have a tolerance of $\pm 2^\circ$. Figures and illustrations are for identification only and are not drawn to scale.

1. INTRODUCTION

This specification covers the requirements for the application of Sealed Sensor Connectors (SSC). The connectors are designed to accept a wire size range of 22 through 14 AWG and are available in 1, 2, 3, 4, 6, and 12 positions. Application may be done by machine for reel-mounted contacts and by hand for replacement loose piece contacts.

When corresponding with TE Connectivity (TE) Personnel, use the terminology provided on this specification to help facilitate your inquiry for information. Basic terms and features of receptacles are provided in Figure 1.

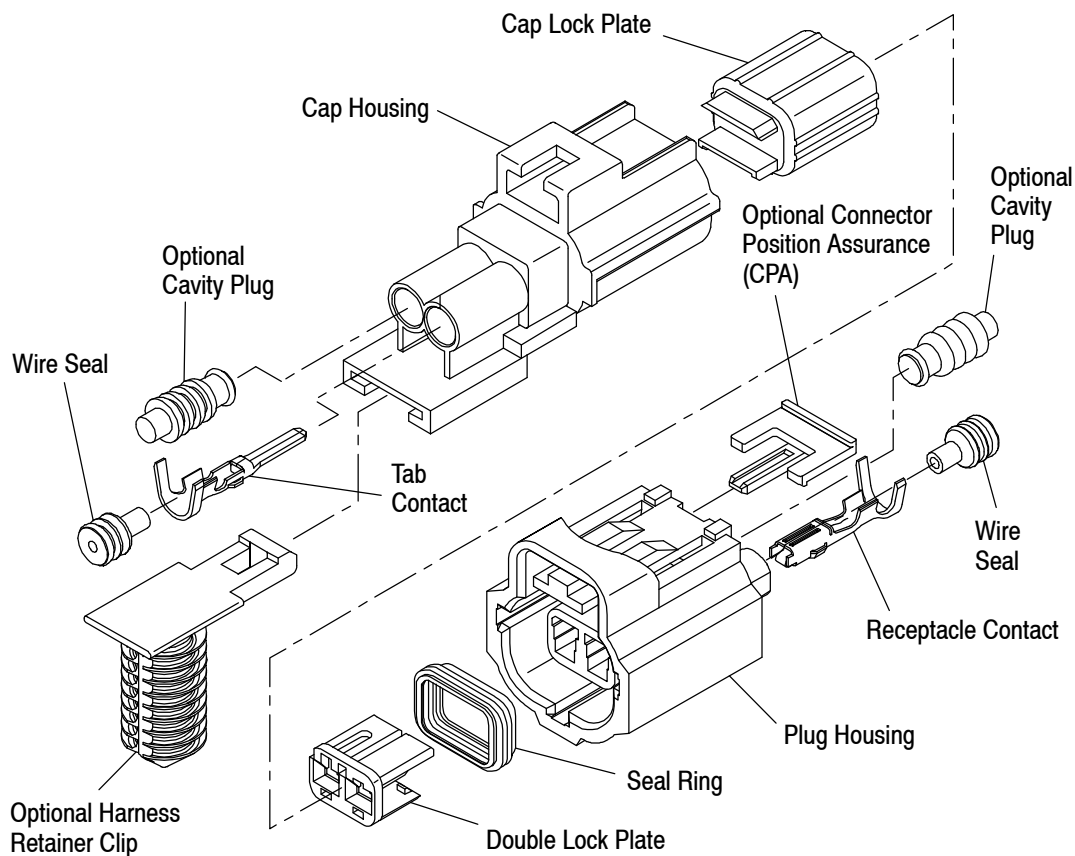

Figure 1

2. REFERENCE MATERIALS
2.1. Revision Summary

- Updated document to corporate requirements
- New logo

2.2. Customer Assistance

Reference Base Part Number 184000 and Product Code 4072 are representative numbers of Sealed Sensor Connectors. Use of these numbers will identify the product line and expedite your inquiries through a service network established to help you obtain product and tooling information. Such information can be obtained through a local TE Representative or, after purchase, by calling the Tooling Assistance Center or Product Information number at the bottom of page 1.

2.3. Drawings

Customer Drawings for specific products are available from the service network. The information contained in Customer Drawings takes priority if there is a conflict with this specification or with any other technical documentation supplied by TE.

2.4. Specifications

Product Specification 108-1790 provides test and performance results.

2.5. Instructional Material

The following list includes available instruction sheets (408- and 411-series) that provide assembly procedures for product, operation, maintenance and repair of tooling, as well as setup and operation procedures of applicators; and customer manuals (409-series) that provide setup, operation, and maintenance of machines.

<u>Document Number</u>	<u>Document Title</u>
408-3295	Preparing Reel Of Contacts for Application Tooling
408-4189	Positioning the Double Lock Plate
408-7424	Checking Terminal Crimp Height or Gaging Die Closure
408-8040	Heavy Duty Miniature Quick Change Applicators (Side-Feed Type)
408-8059	General Preventive Maintenance for Applicators
408-9816	Handling Of Reeled Products
409-5842	AMP-O-LECTRIC* Model "G" Terminating Machine 354500-[]
409-10016	Entry Level Terminator Machine 1338600-[]
411-5322	Double Action Hand Tool (DAHT) .070 Series Sealed Connectors

3. REQUIREMENTS

3.1. Storage

A. Ultraviolet Light

Prolonged exposure to ultraviolet light may deteriorate the chemical composition used in the connector housing material.

B. Reel Storage

When using reeled contacts, store coil wound reels horizontally and traverse wound reels vertically.

C. Shelf Life

The contacts should remain in the shipping containers until ready for use to prevent deformation to the contact. The contacts should be used on a first in, first out basis to avoid storage contamination that could adversely affect signal transmissions.

D. Chemical Exposure

Do not store contacts near any chemicals listed below as they may cause stress corrosion cracking in the contacts.

Alkalies	Ammonia	Citrates	Phosphates	Citrates	Sulfur Compounds
Amines	Carbonates	Nitrites	Sulfides	Nitrites	Tartrates

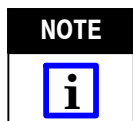

Where the above environmental conditions exist, phosphor-bronze contacts are recommended instead of brass if available.

3.2. Special Characteristics

These sealed waterproof connectors are designed for severe environmental conditions and high temperature applications from -40°C to 150°C [-40°F to 302°F]. Wire sealing is achieved by means of an individual wire seal which is inserted on the wire and crimped in the insulation support of the contact simultaneously with the contact. The interfacial sealing is achieved with a pre-assembled seal ring located in the plug assembly. When mating, the SSC housing provides an audible “click” to indicate proper connector mating. The connector has 6 different sizes and each can provide up to 12 different keying configurations. Optional colors are available for additional keying configurations.

3.3. Wire Selection and Preparation

The receptacle contact design will accept stranded conductors and include configurations to cover the full wire size range of 22 through 14 AWG. There are designs for each insulation diameter range and wire size combination listed in Figure 2. The tab contact design utilizes a wire size range of 24 through 16 AWG. For crimp specifications, refer to Application Specification 114-5082. For additional information when using metric wire, refer to Application Specification 114-3040.

A. Size

The wire size range (stranded copper wire) for SSC is 0.30mm^2 - 2.0mm^2 [22-14 AWG] .

B. Preparation

The appropriate size wire seal must be selected which will accommodate the insulation diameter of the wire being used. The wire seal must be placed on the end of the wire prior to termination. Strip the wire to the dimensions shown in Figure 2.

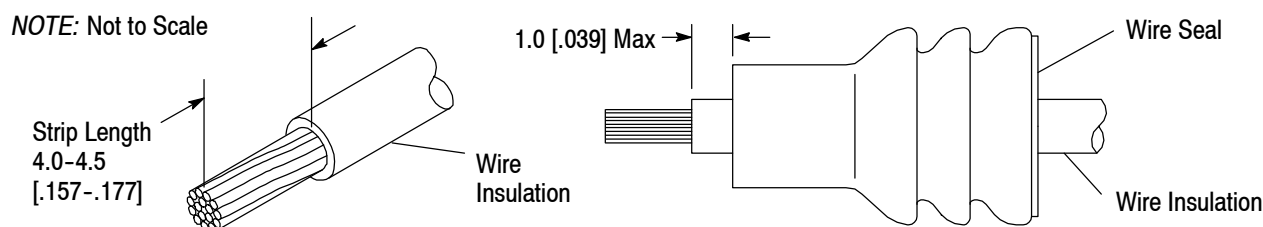

WIRE SIZE		INSULATION DIAMETER RANGE [■]	WIRE BARREL CRIMP		INSULATION BARREL CRIMP		WIRE SEAL	
AWG	mm ²		HEIGHT ± 0.05 [.002]	WIDTH (Ref)	HEIGHT ± 0.10 [.004]	WIDTH (Ref)	INSULATION DIAMETER	COLOR
22	0.30	1.2-2.1 [.047-.083]	1.02 [.040]	2.03 [.080]	2.90 [.114]	3.56 [.140]	1.2-1.7 [.047-.067]	184139-1 (Blue)
---	0.35	1.2-2.1 [.047-.083]	1.02 [.040]	2.03 [.080]	2.90 [.114]	3.56 [.140]	1.2-1.7 [.047-.067]	184139-1 (Blue)
---	0.40	1.2-2.1 [.047-.083]	1.02 [.040]	2.03 [.080]	2.90 [.114]	3.56 [.140]	1.2-1.7 [.047-.067]	184139-1 (Blue)
20	0.50	1.2-2.1 [.047-.083]	1.12 [.044]	2.03 [.080]	2.90 [.114]	3.56 [.140]	1.2-2.1 [.047-.083]	See Note [■]
---	0.75	1.2-2.1 [.047-.083]	1.22 [.048]	2.03 [.080]	2.90 [.114]	3.56 [.140]	1.2-2.1 [.047-.083]	See Note [■]
---	1.00	1.2-2.1 [.047-.083]	1.29 [.051]	2.03 [.080]	2.90 [.114]	3.56 [.140]	1.6-2.1 [.063-.083]	184140-1 (Orange)
20	0.50	1.2-2.7 [.047-.106]	1.17 [.046]	2.29 [.090]	2.90 [.114]	3.56 [.140]	1.2-2.1 [.047-.083]	See Note [■]
---	0.60	1.2-2.7 [.047-.106]	1.19 [.047]	2.29 [.090]	2.90 [.114]	3.56 [.140]	1.2-2.1 [.047-.083]	See Note [■]
---	0.75	1.2-2.7 [.047-.106]	1.24 [.049]	2.29 [.090]	2.90 [.114]	3.56 [.140]	1.2-2.1 [.047-.083]	See Note [■]
18	0.80	1.2-2.7 [.047-.106]	1.24 [.049]	2.29 [.090]	3.05 [.120]	3.56 [.140]	1.6-2.1 [.063-.083]	184140-1 (Orange)
---	1.00	1.2-2.7 [.047-.106]	1.29 [.051]	2.03 [.080]	3.05 [.120]	3.56 [.140]	1.6-2.1 [.063-.083]	184140-1 (Orange)
16	1.20	1.2-2.7 [.047-.106]	1.45 [.057]	2.29 [.090]	3.51 [.138]	3.56 [.140]	2.2-2.7 [.087-.106]	184141-1 (Purple)
---	1.50	1.2-2.7 [.047-.106]	1.50 [.059]	2.29 [.090]	3.51 [.138]	3.56 [.140]	2.2-2.7 [.087-.106]	184141-1 (Purple)
14	2.00	1.2-2.7 [.047-.106]	1.70 [.067]	2.29 [.090]	3.51 [.138]	3.56 [.140]	2.2-2.7 [.087-.106]	184141-1 (Purple)

NOTE: The shaded area uses contact part numbers 184095 and 184373, and the non-shaded area uses contact part numbers 184030 and 184289. [■]For wire insulation diameter range 1.2-1.7, use P/N 184139-1; for 1.6-2.1, use P/N 184140-1.

Figure 2

CAUTION Do not nick, scrape, or cut the wire conductor during the stripping operation.



NOTE Each crimp dimension represents the functional range of a wire/crimp combination when using Sealed Sensor receptacle contacts and semi-automatic applicator equipment. There are tool designs available to meet various application requirements. The developed crimp configuration is unique for each tool design and is acceptable provided the crimp height is within the functional range. For crimp dimensions of a specific tool, refer to instruction sheet packaged with manual tools and applicator log packaged with power tools.

CAUTION Do not damage the wire seal when placing it over the wire.



3.4. Crimp Contact Requirements

Locate the contact to be crimped in the appropriate tooling according to the instructions packaged with that tooling. Detailed instructions covering the placement of contacts in the tooling and the use of such tooling is packaged with each tool.

Terminate the contact according to the directions shipped with the appropriate tooling. See Section 5, TOOLING.

CAUTION Wire seal shall NOT be cut or broken during the crimping operation, nor shall the insulation or wire seal be crimped into the contact wire barrel. Reasonable care should be taken by tooling operators to provide undamaged wire terminations.



A typical receptacle contact as it should appear after crimping is shown in Figure 3. These requirements apply equally to the tab contact.

NOTE Periodic inspections must be made to ensure crimped contact formation is consistent as shown.



A. Crimp Height

The crimp applied to the wire portion of the contact is the most compressed area and is most critical in ensuring optimum electrical and mechanical performance of the crimped contact. The crimp height must be within the dimensions provided in Figure 2.

B. Crimp Length

For optimum crimp effectiveness, the crimp must be within the area shown in Figure 3. Effective crimp length shall be defined as that portion of the wire barrel, excluding bellmouth(s), fully formed by the crimping tool. Instructions for adjusting, repairing, and inspecting tools are packaged with the tools. See Figure 22.

C. Bellmouths

Front and rear bellmouths shall be evident and conform to the dimensions given in Figure 3.

D. Cutoff Tab

The cutoff tab shall be cut to the dimensions shown in Figure 3.

E. Burrs

The cutoff burr shall not exceed the dimensions shown in Figure 3.

F. Wire Barrel Flash

The wire barrel flash shall not exceed the dimensions shown in Figure 3 in Section X-X.

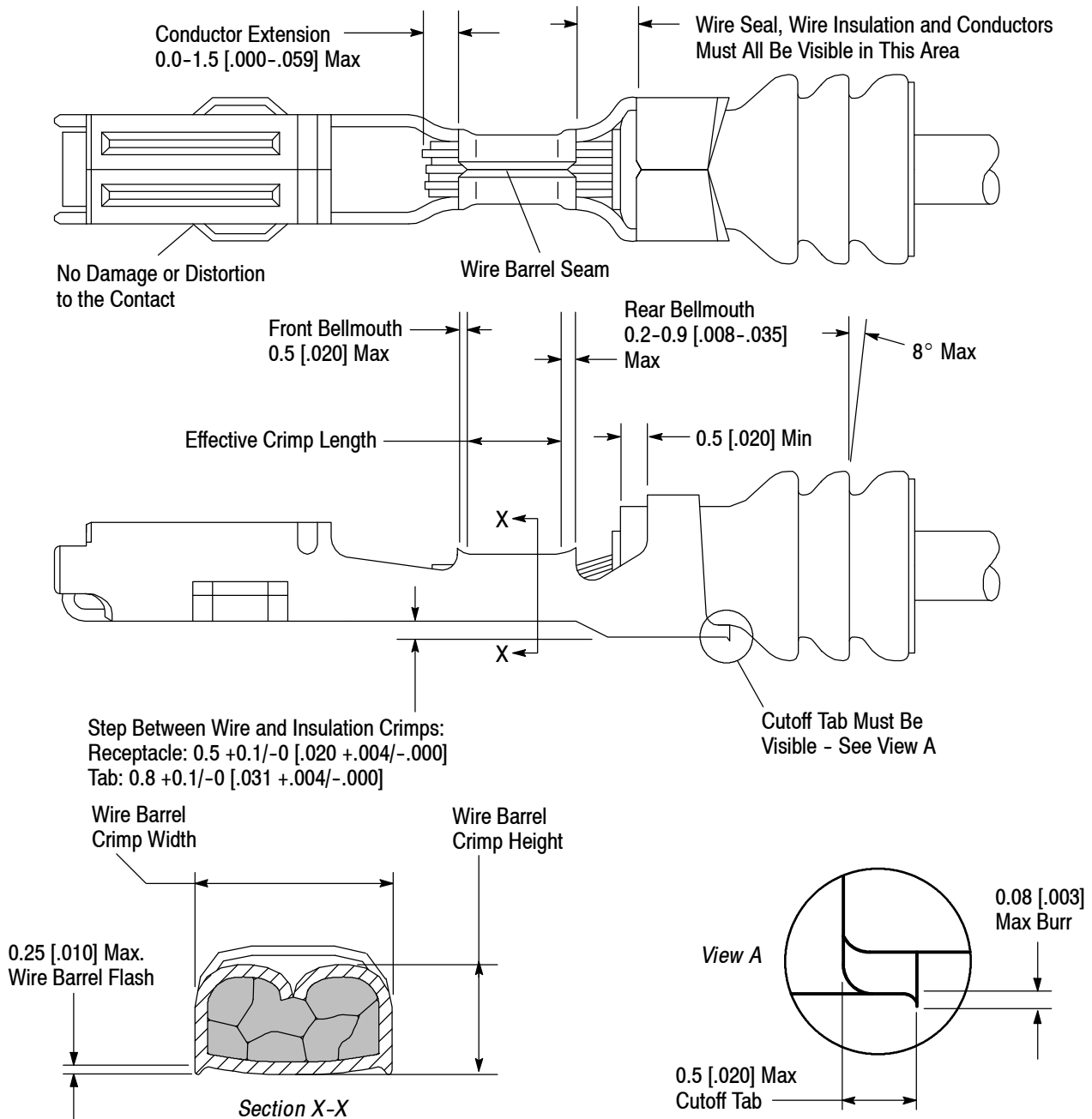

Figure 3

G. Wire Location

After crimping, the wire conductor and insulation must be visible in the transition area between the wire and insulation barrels.

H. Conductor Location

The conductor may extend beyond the wire barrel to the maximum shown in Figure 3.

I. Wire Seal Location

The wire seal may not extend beyond the dimensions shown in Figure 3.

J. Wire Barrel Seam

The wire barrel seam must be closed with no evidence of loose wire strands visible in the seam.

K. Twist and Roll

The twist and roll shall be no more than shown in Figure 4. There shall be no deformation or other damage to the mating portion of the crimped contact that will prevent proper mating.

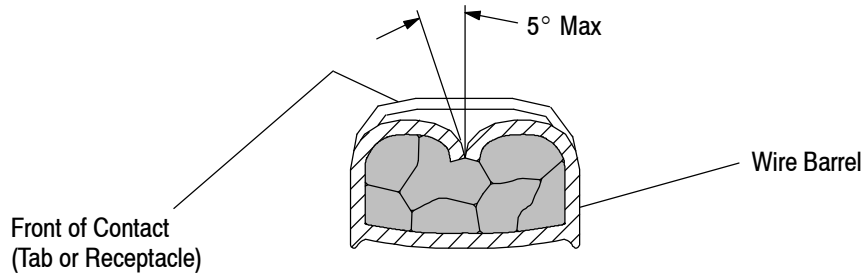

Figure 4

L. Straightness

The force applied during crimping may cause some bending between the crimped wire barrel and the mating portion of the contact. Such deformation is acceptable within the following limits.

1. Up and Down

The crimped contact, including cutoff tab and burr, shall not be bent above or below the datum line more than the amount shown in Figure 5.

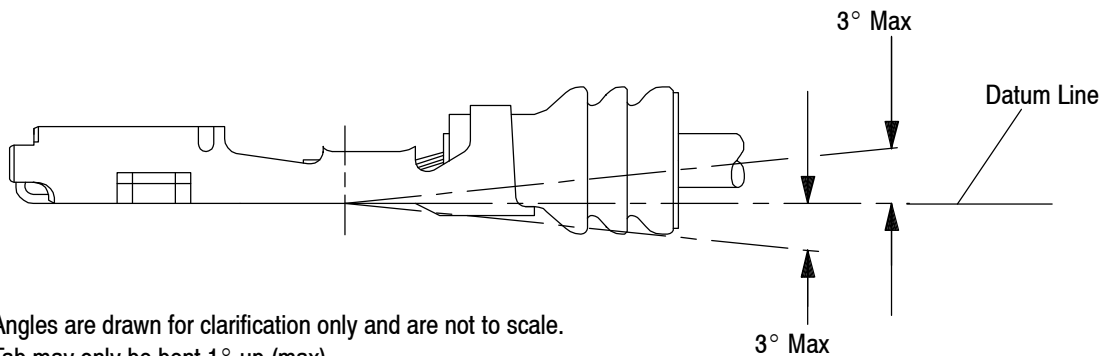

NOTE: Angles are drawn for clarification only and are not to scale.
Tab may only be bent 1° up (max).

Figure 5

2. Side to Side

The side-to-side bending of the contact may not exceed the limits provided in Figure 6.

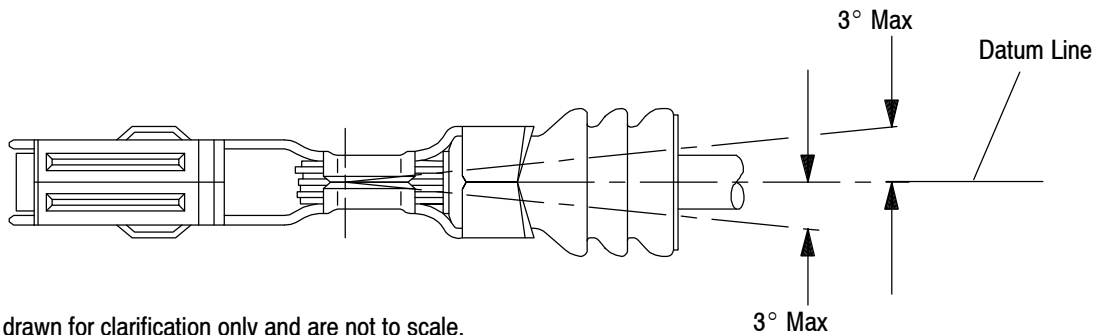

NOTE: Angles are drawn for clarification only and are not to scale.

Figure 6

3.5. Tensile Inspection

Crimped receptacle contacts should hold the wire firmly and have a pull-test tensile value meeting that specified in the table in Figure 7.

NOTE *Adjust tensile testing machine for head travel of 25.4 mm [1 inch] per minute. Directly and gradually apply force for 1 minute.*

CRIMP PULL-OUT TEST			
WIRE SIZE		MINIMUM FORCE	
AWG	mm ²	NEWTONS	POUNDS
22	0.35	57	13
---	0.50	80	18
---	0.60	80	18
20	---	89	20
---	0.75	106	24
---	0.80	106	24
18	---	116	26
---	1.00	123	28
---	1.20	123	28
16	1.50	147	33
14	2.00	178	40

Figure 7

3.6. Housings

Housings are available in 1, 2, 3, 4, 6, and 12 positions for your production requirements. Figure 8 shows the housing configurations. Multiple housing colors are available. The housings are made of glass-filled polybutylene terephthalate (PBT) for class 3 applications, or glass-filled nylon for class 4 applications. The plug housings are pre-assembled with a contact lock plate except for the 12-position which must be assembled as shown in Figure 10. The cap housing must be assembled as shown in Figure 13.

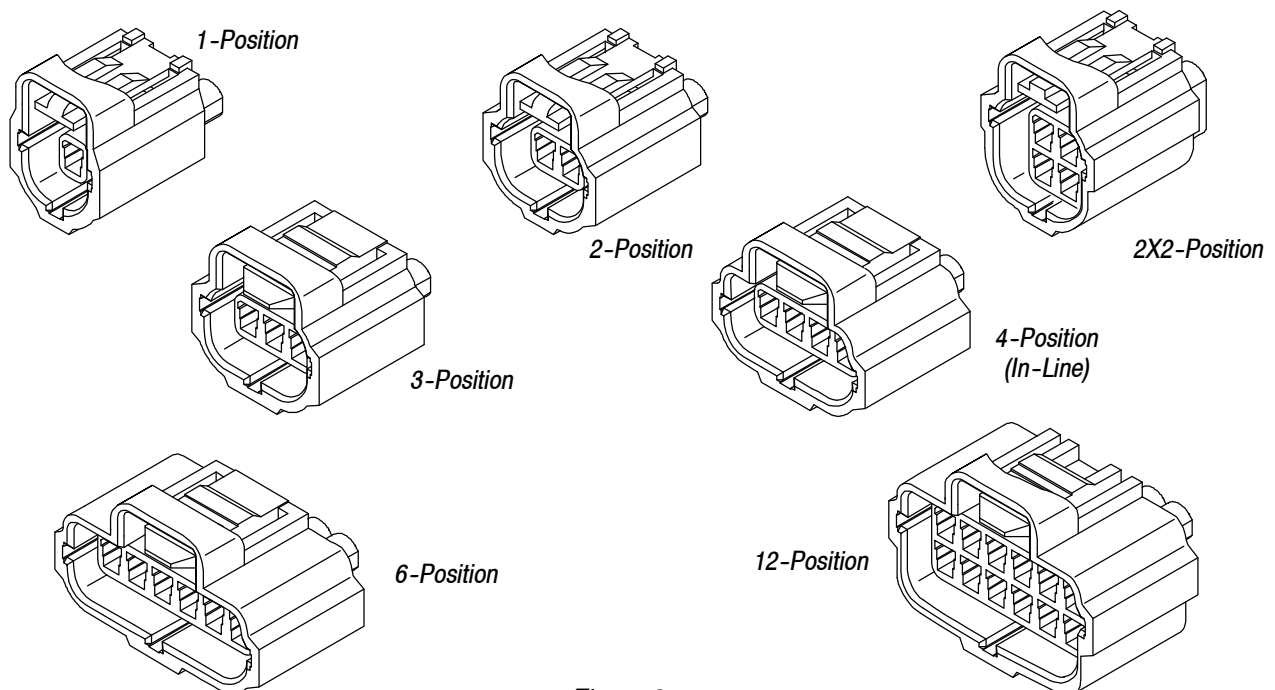
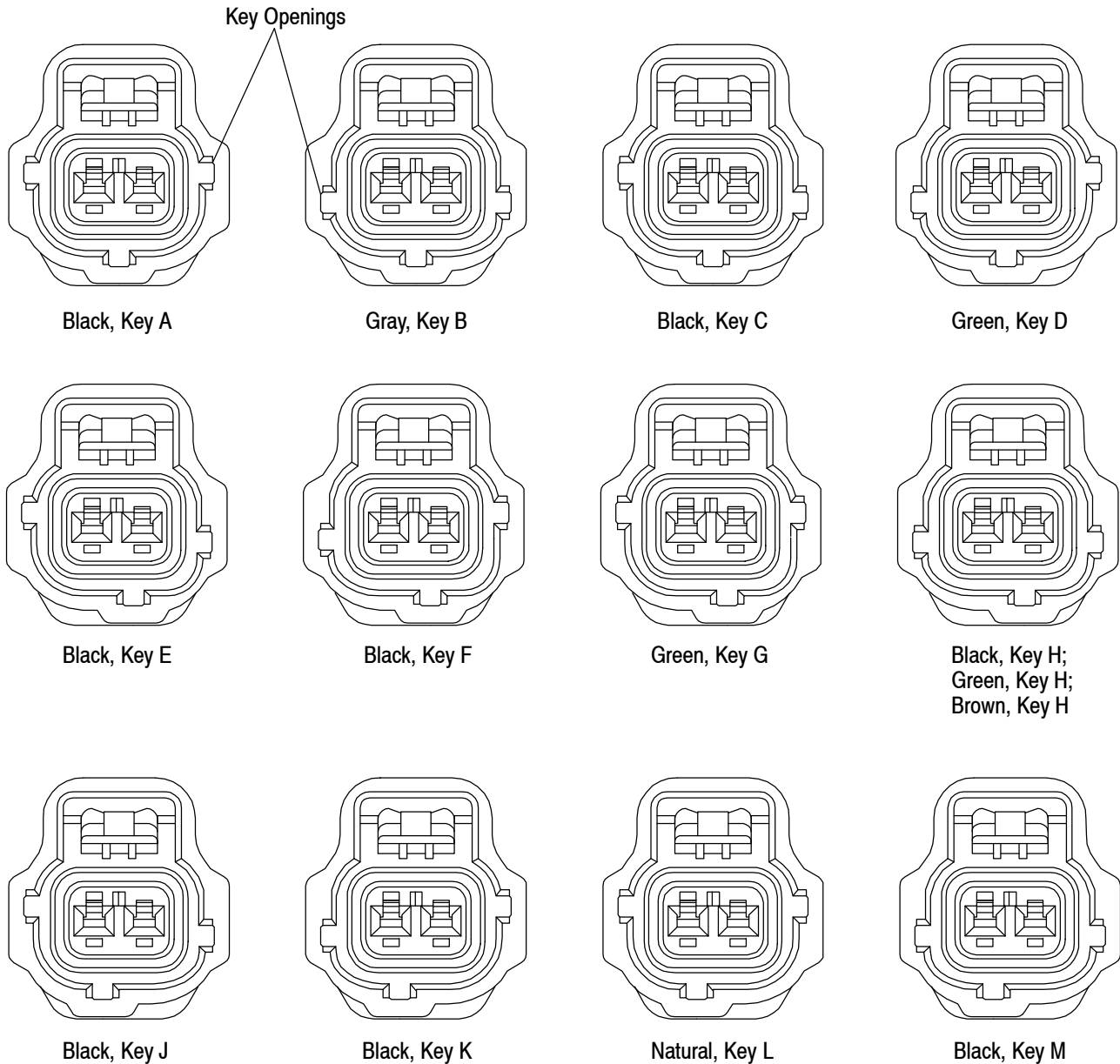

Figure 8

3.7. Housing Keying Configurations

A variety of housing keying configurations is available for your production requirements. These various keying configurations are shown in Figure 9.



NOTE: Two position shown, other positions available in different keying configurations.

Figure 9

3.8. Placement of Crimped Receptacle In Plug Assembly

NOTE The 12-position lock plate is sold as a separate piece and must be assembled by the customer. See Figure 10.



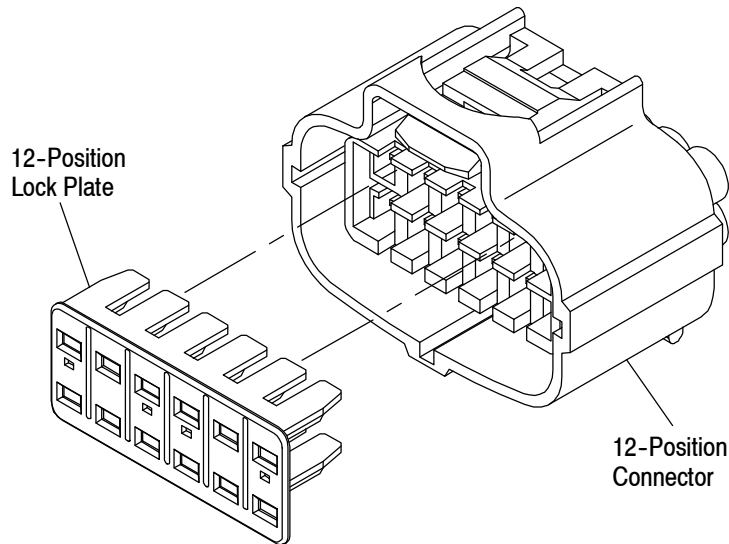

Figure 10

A. Insertion of Crimped Receptacle

The lock plate must be in a pre-staged position before the crimped receptacle can be inserted in the plug assembly. Holding the terminated receptacle contact with the wire barrel seam facing toward the latch on the housing, insert the crimped receptacle into the plug assembly. A click will be heard when the crimped receptacle is fully inserted. See Figure 11.

B. Engagement of Lock Plate

After the crimped receptacles have been inserted, press the lock plate (pre-staged position as shown in Figure 11A) into the plug assembly to lock the crimped receptacles into the plug housing. A click will be heard when the lock plate (engaged position as shown in Figure 11B) is fully engaged.

NOTE

If there is a difficulty in inserting the lock plate, check the crimped receptacle to ensure full insertion.

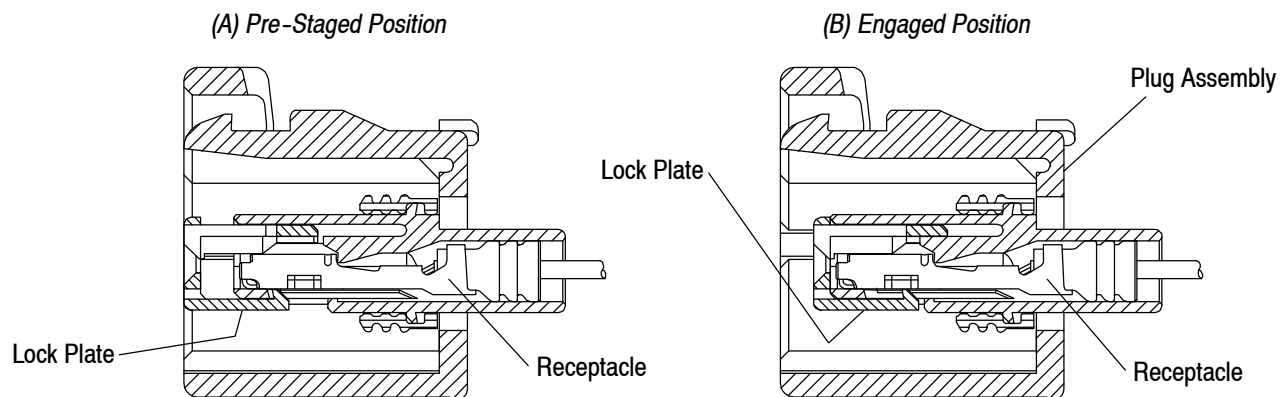

Figure 11

3.9. Placement of Tab Contact in the Cap Housing

A. Insertion of Tab Contact

Holding the terminated tab contact with the wire barrel seam facing toward the latch on the housing, insert the tab contact into the cap housing. A click will be heard when the tab is fully inserted. See Figure 12.

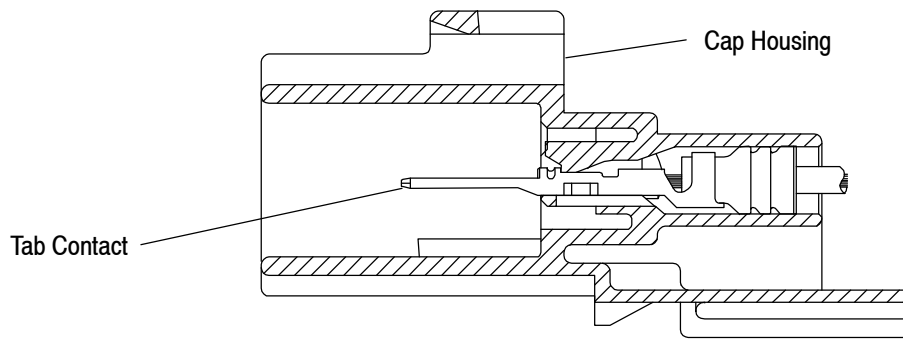

Figure 12

B. Engagement of Lock Plate

After the crimped tab contacts have been inserted, assemble the lock plate and press it into the plug assembly to lock the crimped tab contacts into the plug housing. A click will be heard when the lock plate is fully engaged. See Figure 13.

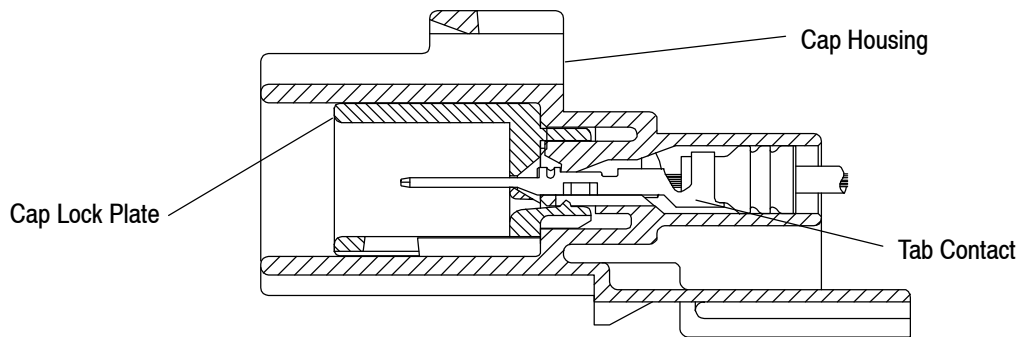

Figure 13

3.10. Strain Relief

If required, the wires can be bundled together with cable ties and secured with fixed clamps. The wires must not be confined in any way that would restrict floating action of the contact in the housing. Normally the individual wires should be dressed to a bend radius of *at least* ten times the insulation diameter.

Optional harness retainer clips are available to secure the harness to the chassis or device. Slide the retainer into the slot in the cap housing until it locks into place. A tactile and audible click will be heard when the retainer clip is fully seated. See Figure 14.

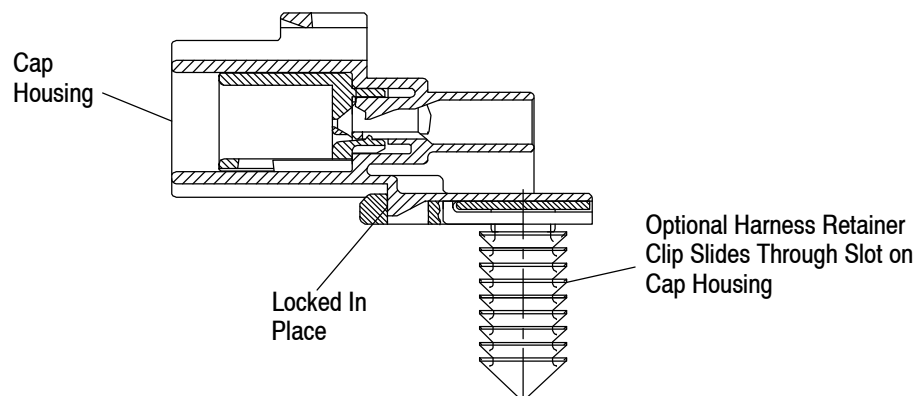

Figure 14

3.11. Mating of Connectors

To ensure a proper circuit connection, the connectors must be mated as shown in Figure 15. Various keying configurations are available to prevent mis-mating of connectors. The housing latches will lock and a tactile and audible click will be heard when the plug and cap housing have reached the fully mated position.

An optional Connector Position Assurance (CPA) tab is available on the 3-position, 4-position in-line, and the 4-position (2x2) matrix plug assemblies. The purpose of the CPA is to provide additional assurance of a fully mated connector system.

The CPA is inserted on the latch of the plug housing until fully locked in place. When the cap housing is mated to the plug housing, the CPA tab moves out of location enabling the user to move the CPA forward and provide a visual check that the two connectors are fully seated. See Figure 15.

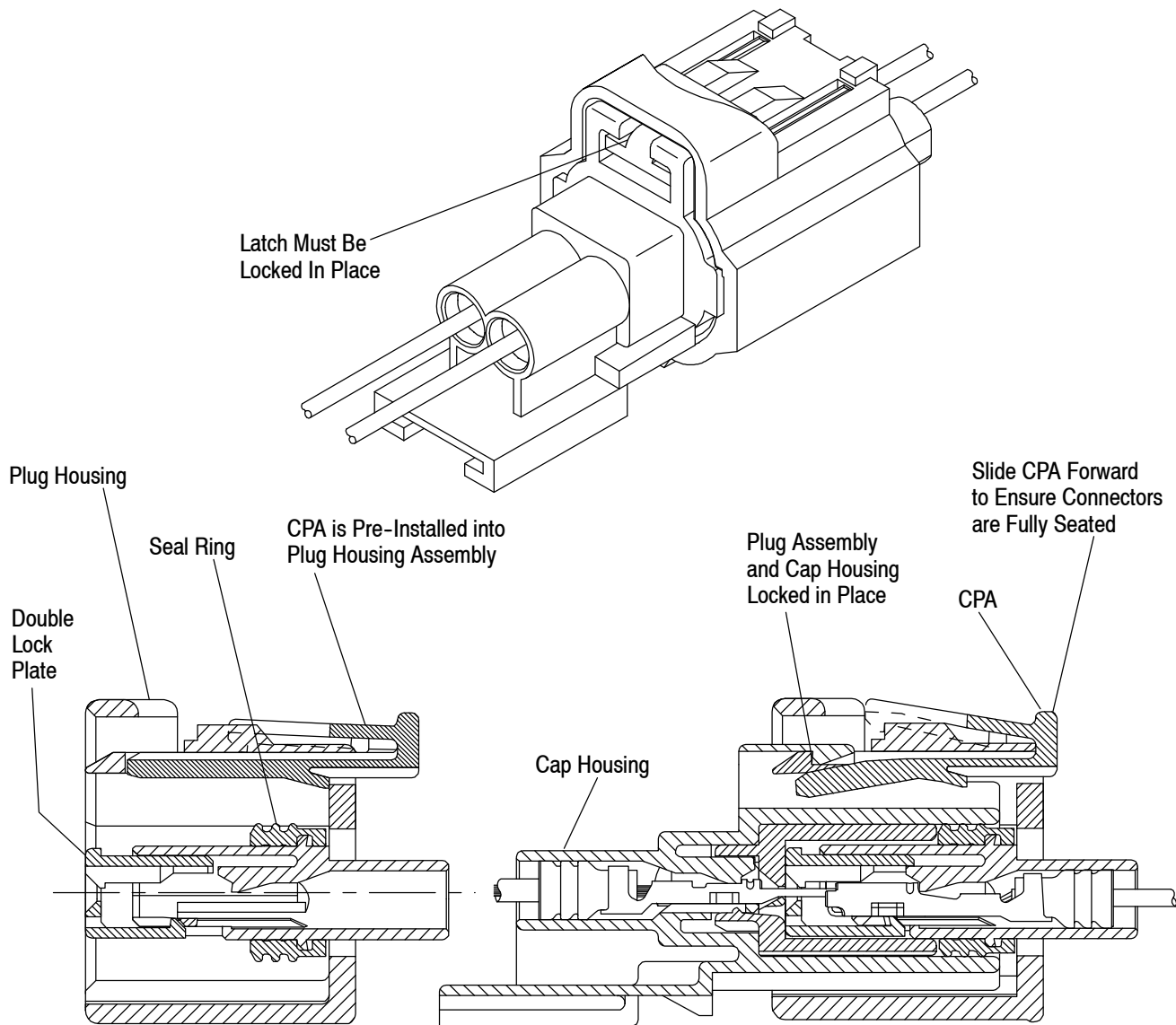

Figure 15

3.12. Unmating of Connectors

To unmate the cap housing and plug housing, press on the plug housing ribs as shown Figure 16.

NOTE



If the plug housing has a CPA installed, first move the CPA toward the wire end of the housing until it stops, then press on the plug housing ribs to unmate the connectors.

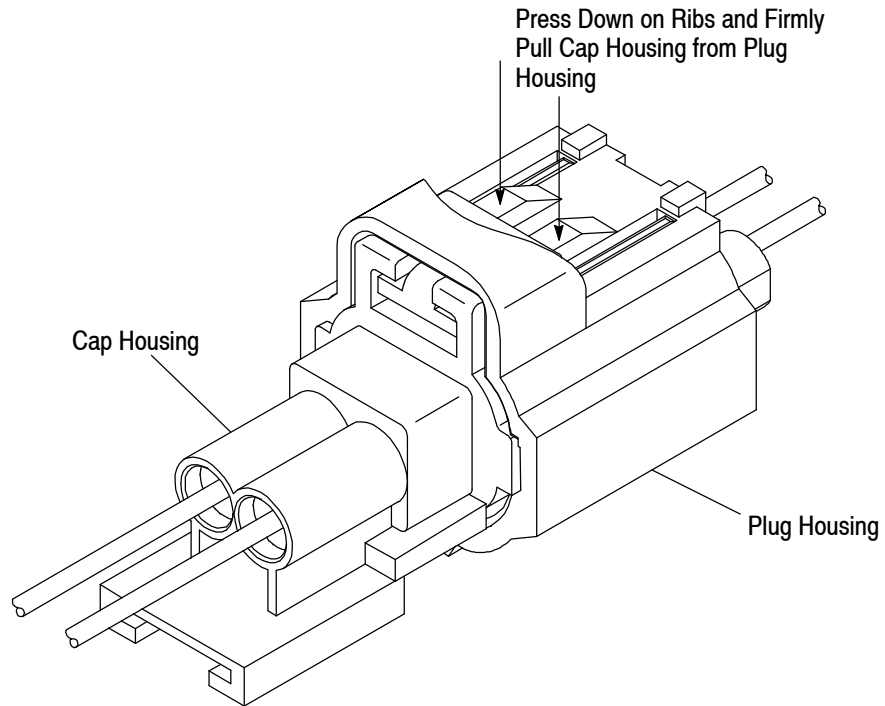
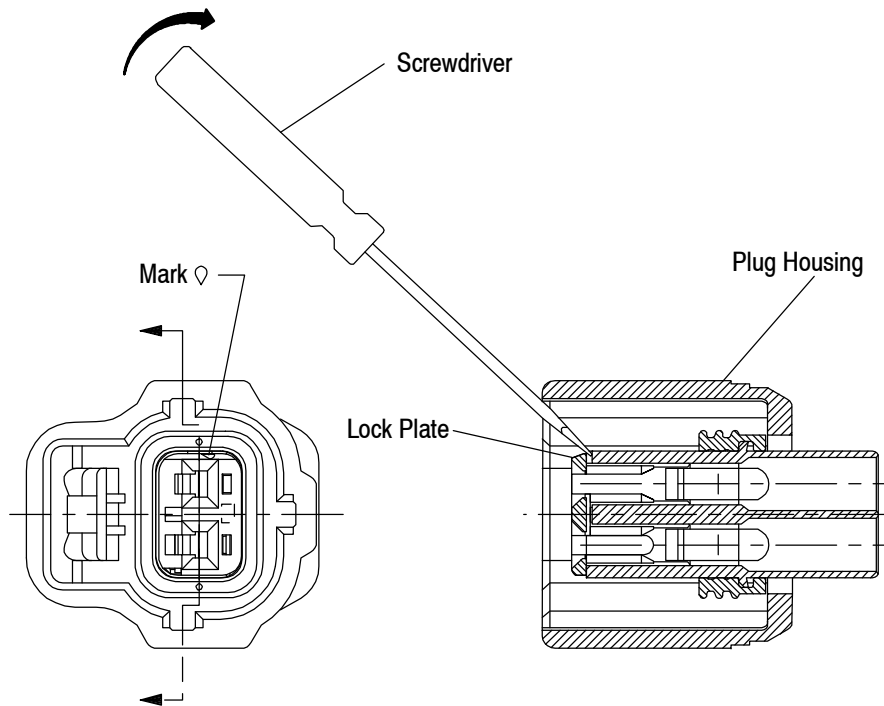

Figure 16

3.13. Disengagement of Lock Plate from Plug Housing

Insert a jeweler's number 2 screwdriver into the slit between the marked position of the lock plate and plug assembly wall. Lift up the lock plate until it is unlocked. See Figure 17.



NOTE: For 1-, 2-, and 3-position assemblies.

Figure 17 (cont'd)

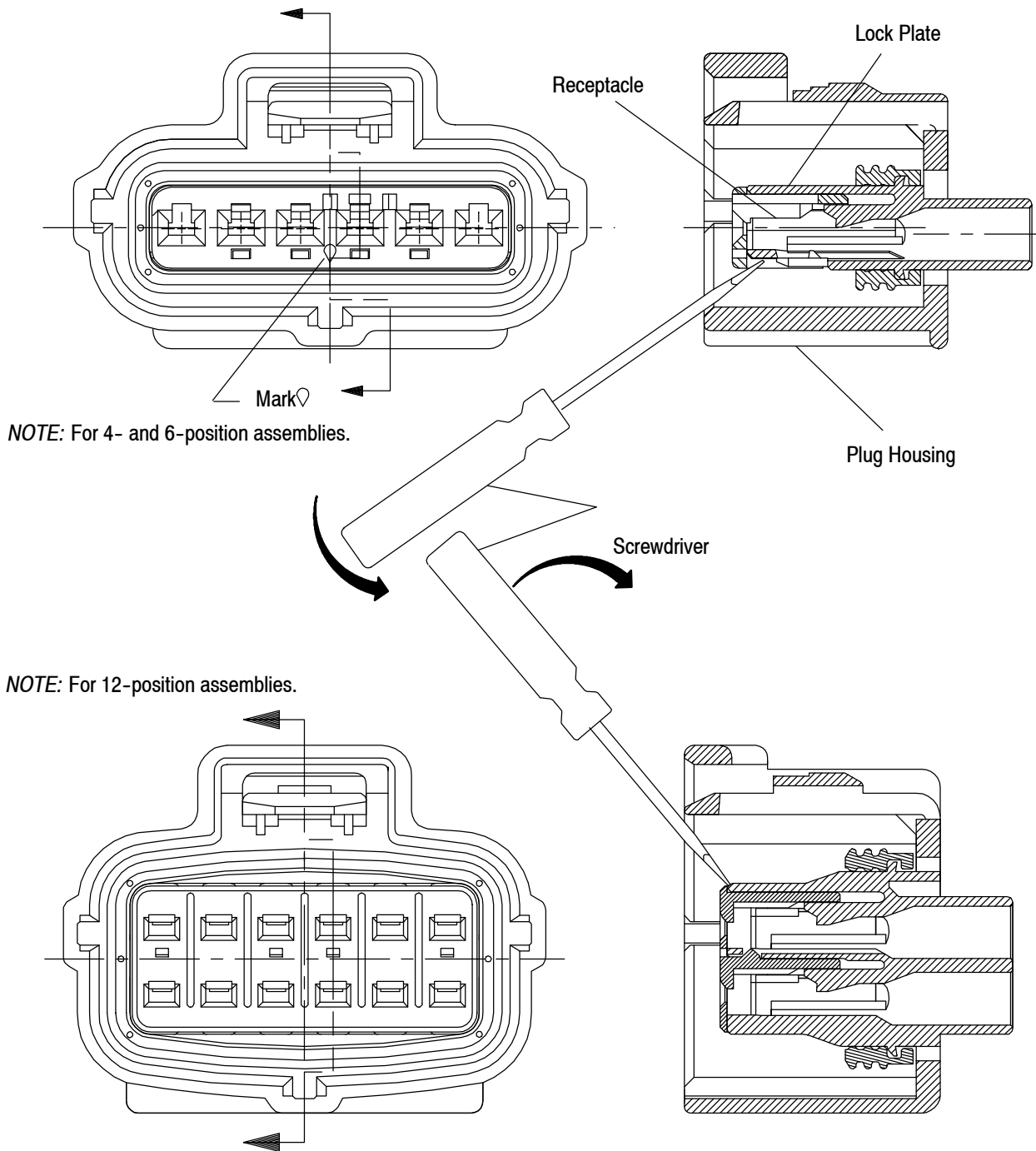

Figure 17 (end)

3.14. Extraction of the Receptacle Contact from Plug Housing

While holding the plug housing, push the receptacle contact forward. Insert a jeweler’s number 2 screwdriver between the contact latch and the receptacle assembly as shown in Figure 18. Lift the contact latch and pull the wire and receptacle contact out of the housing.



CAUTION Do NOT insert the screwdriver into the mating end of the receptacle contact. Damage may occur.

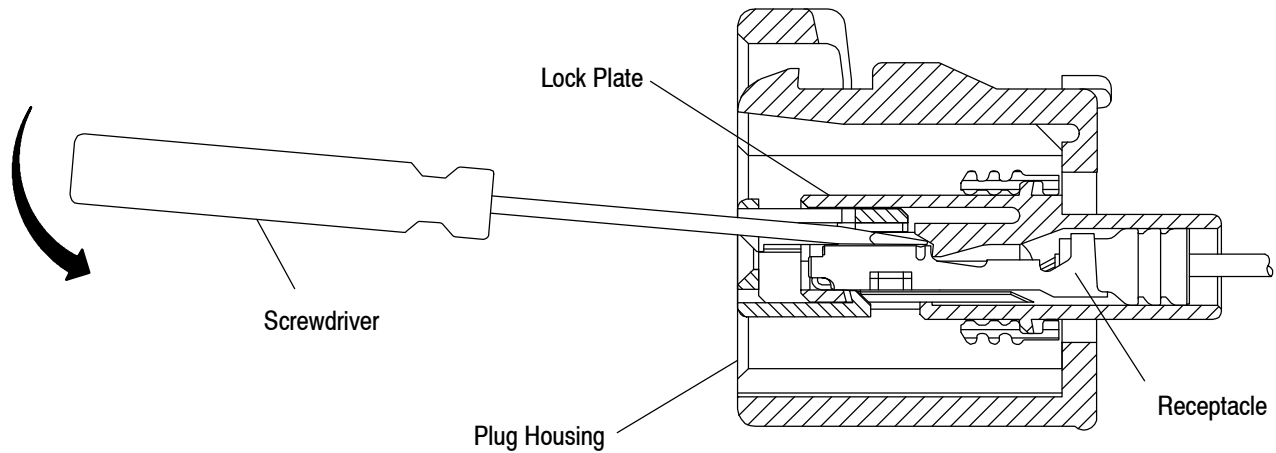

Figure 18

3.15. Extraction of the Lock Plate from Cap Housing

Remove the cap lock plate from the cap housing by placing the screwdriver in the slot of the lock plate and pulling the lock plate out of the cap housing as shown in Figure 19.

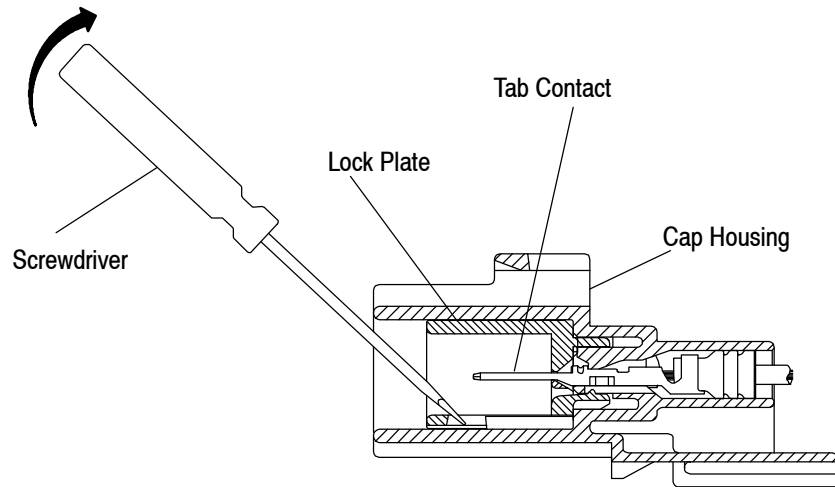

Figure 19

3.16. Extraction of the Tab Contact from the Cap Housing

While holding the housing, push the tab contact forward and insert a jeweler's number 2 screwdriver between the contact latch and tab contact. Lift the contact latch and pull the wire and tab contact out of the cap housing. See Figure 20.

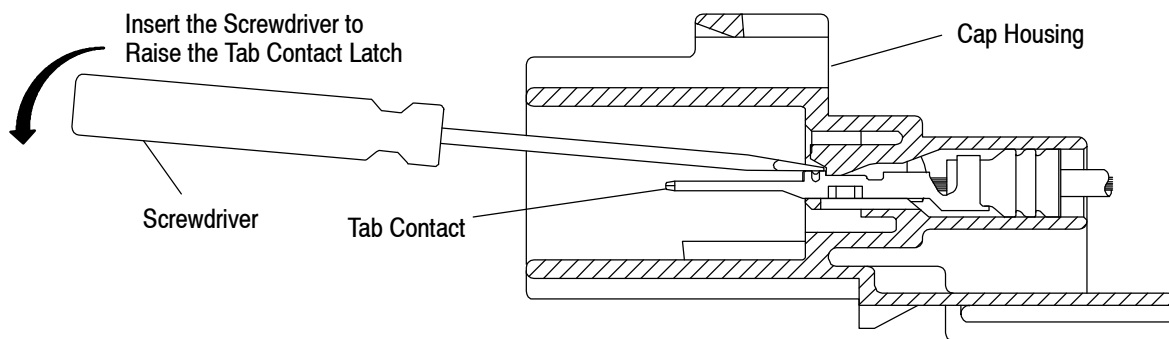

Figure 20

3.17. Optional Cavity Plug

In order to maintain a water-tight connector system, optional cavity plugs must be used to seal all unused circuits. Insert the cavity plug from the wiring side of the connector housing until it is fully seated as shown in Figure 21.

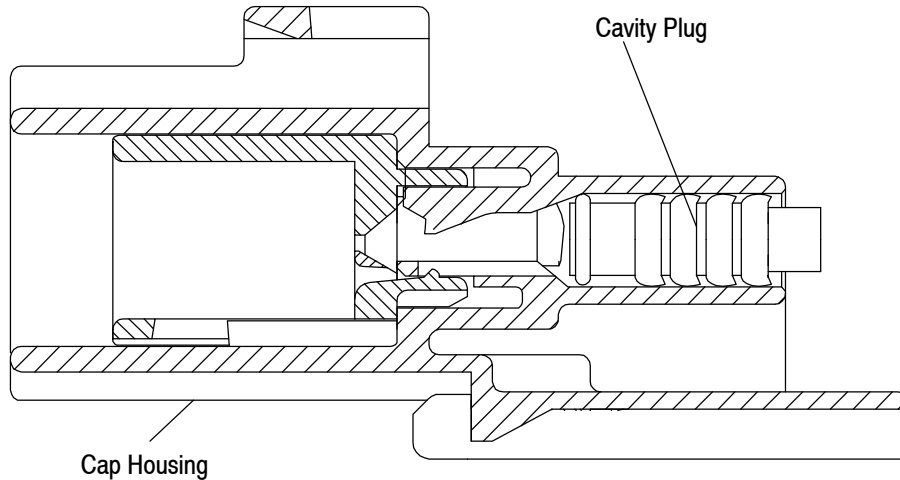

Figure 21

3.18. Repair/Replacement

A damaged contact can be removed and replaced with a new one. All contacts must be removed from a damaged connector housing and the housing replaced with a new one.

4. QUALIFICATIONS

Sealed Sensor Connectors are Qualified to USCAR. The product has not been submitted to Underwriters Laboratories Inc. (UL) or CSA International for agency evaluation and testing.

5. TOOLING

This section provides a selection of tools for various application requirements. They include hand tools for manual application of loose piece contacts, and semi-automatic and automatic machines for power assisted application of strip form contacts. Modified designs and additional tooling concepts may be available to meet other application requirements. For additional information, contact one of the service groups at the bottom of page 1. A listing of tooling recommendations covering the full wire size range is provided in Figure 22.

- **Hand Tools**

Hand crimping tools that accommodate the full wire size range are designed for prototype and low-volume applications, such as repair of damaged contacts.

- **Applicators**

Applicators are designed for the full wire size range of strip-fed, precision formed contacts, and provide for high volume, heavy duty, production requirements. The applicators can be used in bench or floor model power units.

NOTE



Each applicator is shipped with a metal identification tag attached. DO NOT remove this tag or disregard the information on it. Also, a packet of associated paperwork is included in each applicator shipment. This information should be read before using the applicator; then it should be stored in a clean, dry area near the applicator for future reference. Some changes may have to be made to the applicators to run in all related power units. Contact the Tooling Assistance Center number located at the bottom of page 1 for specific changes.

- **Power Units**

A power unit is an automatic or semi-automatic device used to assist in the application of a product. Power unit includes the power source used to supply the force or power to an applicator.

CONTACT	WIRE SIZE,	INSULATION DIAMETER	HAND TOOL (411-5322)	APPLICATOR (408-8040)	POWER UNIT (DOCUMENT)
Receptacle	0.5 mm ² - 1.0 mm ²	1.6-2.1 [.063-.071]	---	680143-[]	354500-[] (409-5842)
					1338600-3, -4 (409-10016)
	20-16 AWG	2.0-2.6 [.078-.102]	755262-1	680144-[]	354500-[] (409-5842)
					1338600-3, -4 (409-10016)
Tab	20-16 AWG	2.0-2.6 [.078-.102]	755241-1	567266-1	Contact TE using the phone numbers at the bottom of page 1 for information about power units used in the application of tab contacts using wire seals.

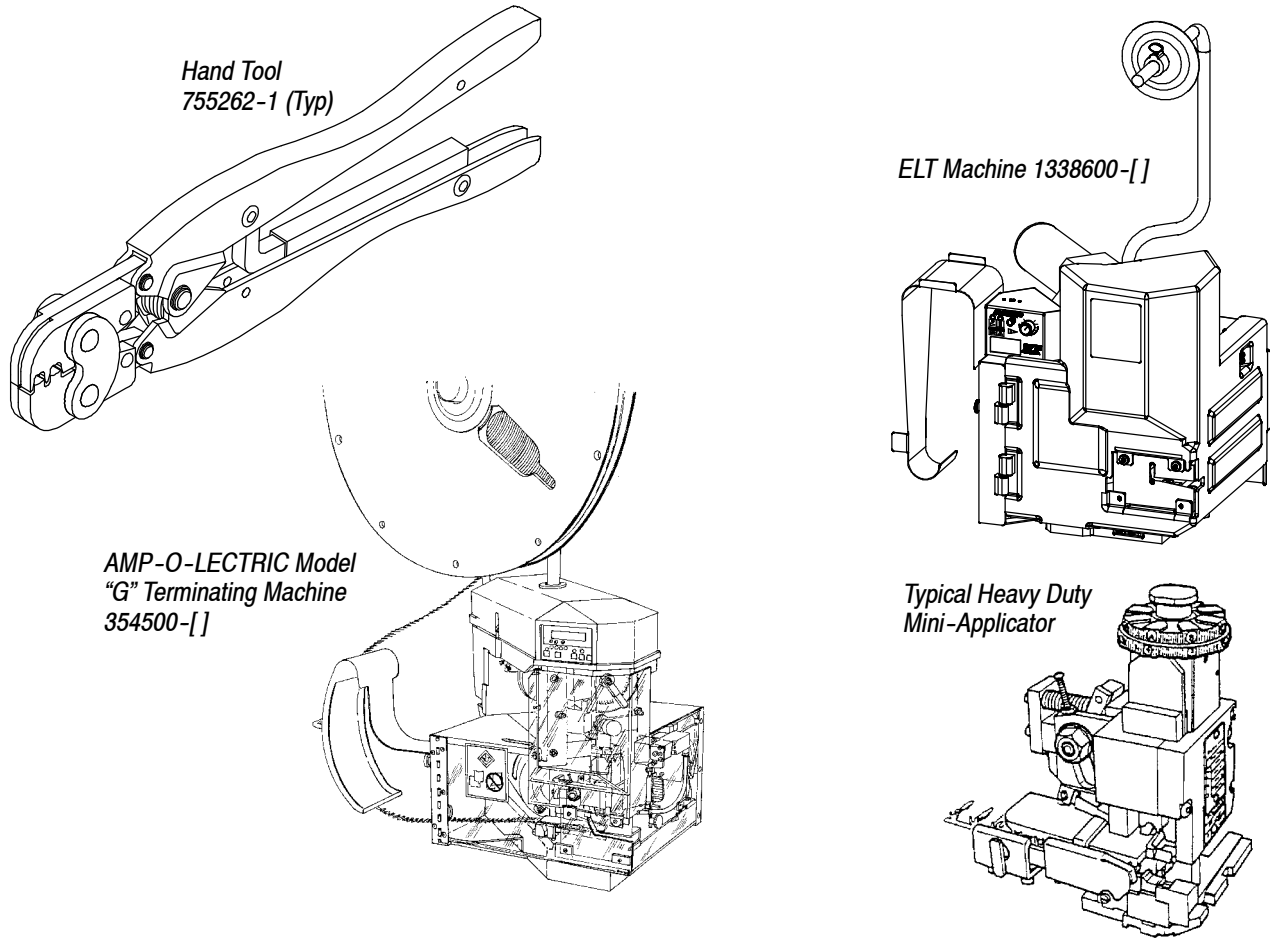

Figure 22

6. VISUAL AID

Figure 23 shows a typical application of Sealed Sensor Connectors. This illustration should be used by production personnel to ensure a correctly applied product. Applications which DO NOT appear correct should be inspected using the information in the preceding pages of this specification and in the instructional material shipped with the product or tooling.

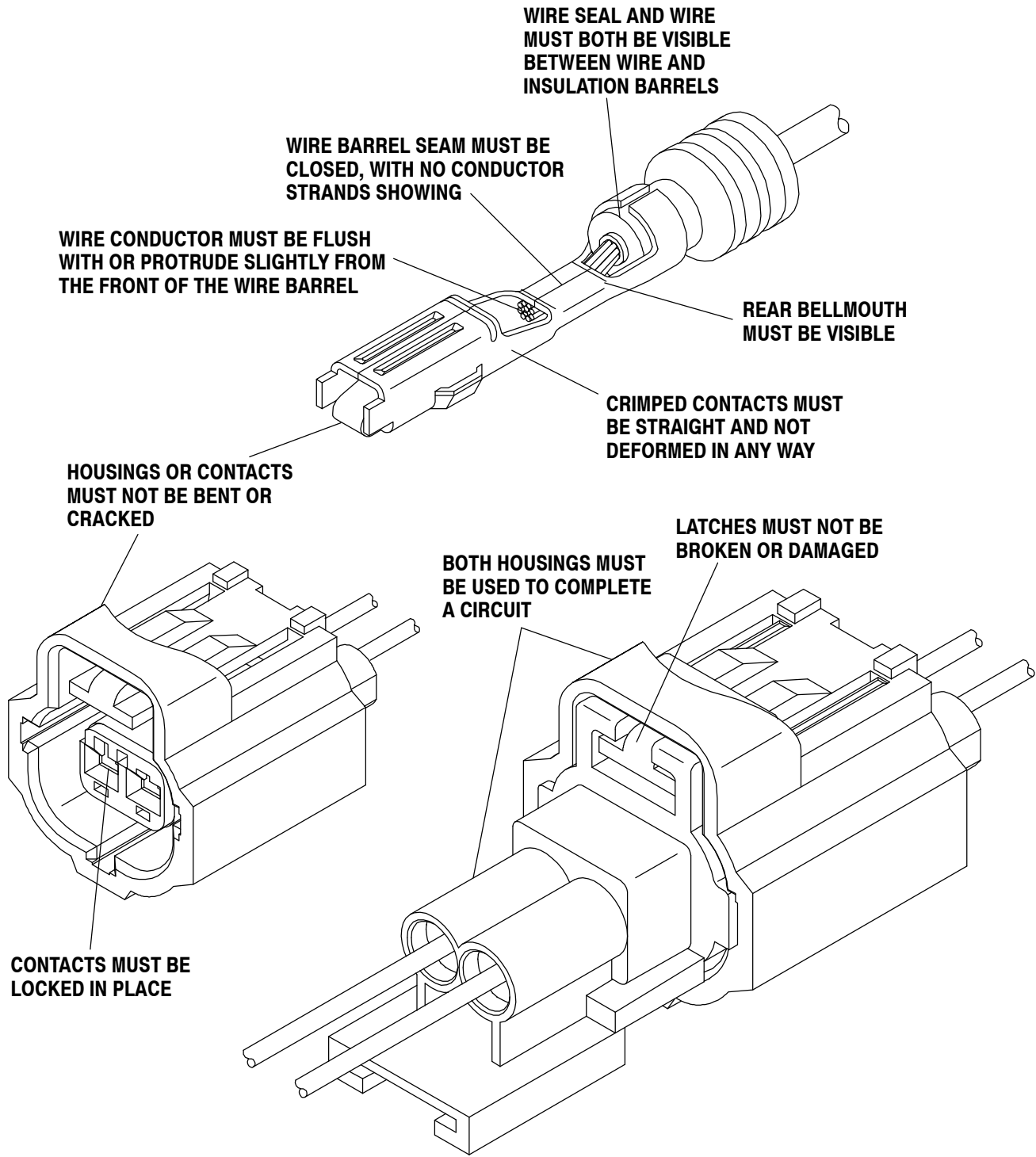

FIGURE 23. VISUAL AID