



1.0 Megapixel SMIA Processor

DATA BRIEF

FEATURES

- Supports the VS6650 1.0 Megapixel (1152H x 864V) and the VS6590 SVGA (800H x 600V) camera modules
- SMIA¹ class 0 (208 Mbit/s) sensor interface
- Up to 30 frame per second (fps) operation at SVGA or 15 fps at 1.0 Megapixel
- Dedicated digital image processing functions including defect correction, noise filtering, lens shading correction, demosaicing, sharpening, gamma correction and color space conversion
- Embedded camera controller for automatic exposure control, automatic white balance, black level compensation, 50/60 Hz flicker detection and elimination
- Fine image downscaler, 13 steps of 0.5 from 1x to 7x, 5 steps of 1.0 from 7x to 12x, maximum CIF output image size
- ITU-R BT.656-4 YUV (YCbCr) 4:2:2, RGB 565, RGB 444 or JPEG output formats with embedded syncs
- JPEG compression with programmable target file size
- SMIA Class 0 (208 Mbit/s) host interface
- 8-bit parallel video interface with separate horizontal and vertical syncs, 24 MHz clock
- Two-wire control interface (CCI)
- Single 1.8 V power supply
- 15 μ W standby power consumption
- TFBGA 56, 6mm x 6mm AFOP leadfree package
- Pin compatible with the STV0974 processor

DESCRIPTION

The STV0976 is a low power digital image processor supporting the VS6650 1.0 Megapixel SMIA camera module at up to 15 fps, or the VS6590 SVGA camera module at up to 30 fps.

The STV0976 performs all the necessary operations required to capture state-of-the-art megapixel images, including JPEG compression and viewfinder generation, in a small footprint and low power budget. With both video input and output being SMIA-class 0, hardware acceleration in SMIA architecture achieves leading edge-mobile-imaging capabilities.

APPLICATIONS

- Mobile phone
- PDA
- Wireless security camera

PART NUMBERING

Part Number	Description
STV0976E	TFBGA 56 AFOP lead-free, tray packing
STV0976E/TR	TFBGA 56 AFOP lead-free, 13 inch tape-and-reel packing



1. Standard Mobile Imaging Architecture
visit www.smia-forum.org

APPLICATION DIAGRAM

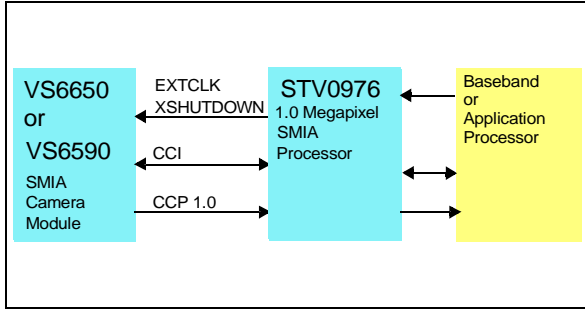

BLOCK DIAGRAM

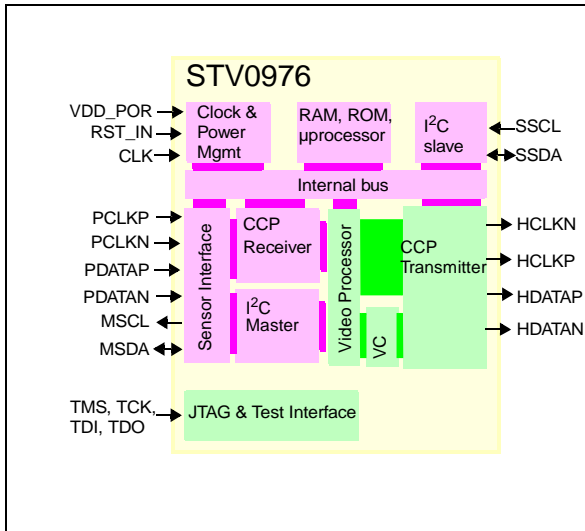

TECHNICAL SPECIFICATIONS

Sensor support	VS6650 1.0MP SMIA VS6590 480kP
Frame rate	1 to 15 Hz (1152H x 864V) 1 to 30 Hz (800H x 600V)
Gamma correction	Standard, S-curve
Image Crop	Arbitrary size
Image Downscale	x1 to x7 in 0.5 steps x7 to x12 in 1.0 steps
Image Compression	JPEG on YUV 4:2:2, programmable quantization tables
Output Format	YUV 4:2:2 RGB 565, RGB 444 JPEG
Video Output Interface	SMIA class 0 high-speed serial 208Mbit/s data/clock 1.8 V LVDS
Video Output Interface (2)	8-bit parallel video HSYNC/VSYNC/PCLK 24 MHz max
Clock input	6.5 to 27 MHz square 13 MHz typ.
Supply voltage	1.8 V ± 0.1 V digital
I/O voltage	1.8 V CMOS levels
Power consumption	Streaming 15 fps: 85 mW max Power down: 60 µW max.
Package type	TFBGA 56 AFOP lead-free STV0974 compatible
Package size (mm)	6 x 6 x 1.2 (wlh)

TEMPERATURE RANGES

Storage	-40 to +85 °C
Operating	-25 to +70 °C

REVISION HISTORY

Table 1. Revision History

Date	Revision	Description of Changes
October 2004	1	First Issue

Information furnished is believed to be accurate and reliable. However, STMicroelectronics assumes no responsibility for the consequences of use of such information nor for any infringement of patents or other rights of third parties which may result from its use. No license is granted by implication or otherwise under any patent or patent rights of STMicroelectronics. Specifications mentioned in this publication are subject to change without notice. This publication supersedes and replaces all information previously supplied. STMicroelectronics products are not authorized for use as critical components in life support devices or systems without express written approval of STMicroelectronics.

The ST logo is a registered trademark of STMicroelectronics.

All other names are the property of their respective owners

© 2004 STMicroelectronics - All rights reserved

STMicroelectronics group of companies

Australia - Belgium - Brazil - Canada - China - Czech Republic - Finland - France - Germany - Hong Kong - India - Israel - Italy - Japan - Malaysia - Malta - Morocco - Singapore - Spain - Sweden - Switzerland - United Kingdom - United States of America

www.st.com

This datasheet has been download from:

www.datasheetcatalog.com

Datasheets for electronics components.