

SC ADAPTER ASSY. P/N	SPLIT SLEEVE MATERIAL
106116-2100	Zr
106116-2400	Ph. Bronze

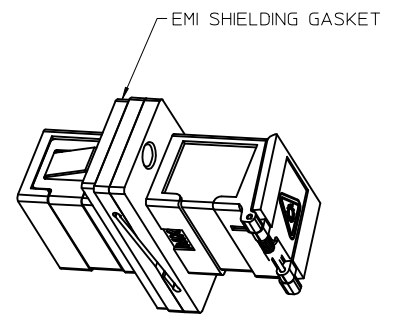
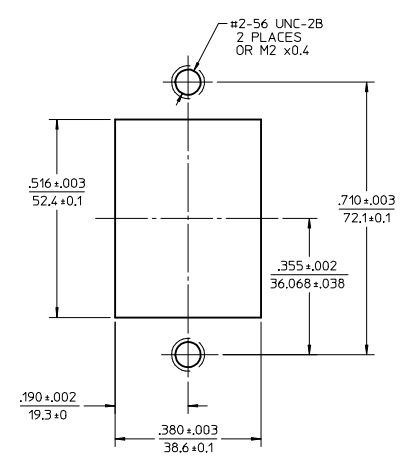
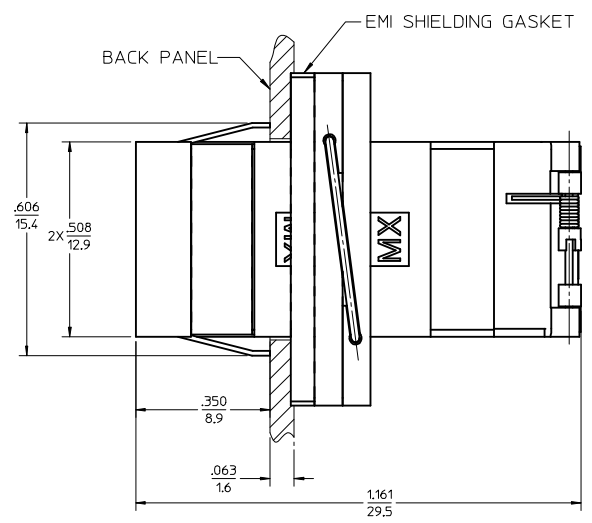
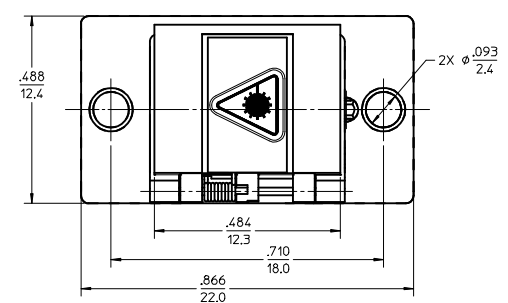
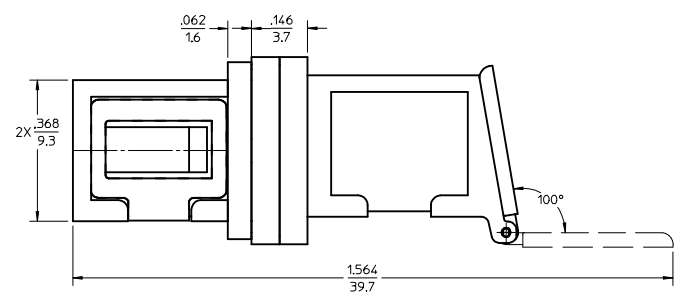

RECOMMENDED MOUNTING CUTOUT FOR .063" THICK PANEL

- NOTES:
- ALL DIMENSIONS ARE FOR REFERENCE ONLY.
 - ADAPTERS TO BE PACKAGED IN TRAY.

ENTER DESCRIPTION EC NO: MF2013-0137 DRWN: YBEDNYAK 2012/09/10 CHKD: LGUMIN 2012/09/19 APPR: LGUMIN	QUALITY SYMBOLS	GENERAL TOLERANCES (UNLESS SPECIFIED)	DIMENSION STYLE	SCALE	DESIGN UNITS	THIRD ANGLE PROJECTION
	▽=0	mm INCH	IN/MM	4:1	INCH	
	▽=0	4 PLACES ± --- ± .0002	DRAWN BY DATE	PG IBL IN	2005/10/31	TITLE
	▽=0	3 PLACES ± 0.005 ± .005	CHECKED BY DATE	SC METAL ADAPTER W/FLANG (SCREW MOUNTING)		
		2 PLACES ± 0.13 ± .01	APPROVED BY DATE			
		1 PLACE ± 0.25 ± ---				
		0 PLACE ± ±	MATERIAL NO.	DOCUMENT NO.	SHEET NO.	
		ANGULAR ±1/2°	SEE TABLE	SD-106116-2100	1 OF 1	
		DRAFT WHERE APPLICABLE MUST REMAIN WITHIN DIMENSIONS	SIZE C	THIS DRAWING CONTAINS INFORMATION THAT IS PROPRIETARY TO MOLEX INCORPORATED AND SHOULD NOT BE USED WITHOUT WRITTEN PERMISSION		