

Model

Miniature Switch Mode Power Supply

AAD160

H.A.L.T. Highly Accelerated Life Testing
TESTED

- 160 Watts output power
- Power Factor Correction
- Parallel/Redundant Operation
- Up to 88% Efficiency

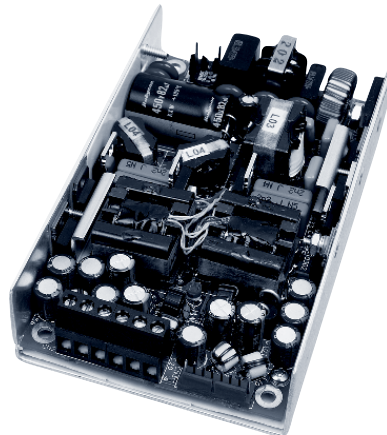

Electrical Specifications

Input Voltage:	90-264 VAC, 47-63 Hz
Input Current:	<2A RMS @ 115 VAC @ full load <1A RMS @ 230 VAC @ full load
Inrush Current:	<35A, pk @ 132 VAC @ cold start <75A, pk @ 264 VAC @ cold start
Power Factor:	>0.98 @ full load @ 115/230VAC input
Harmonic Distortion:	Meets EN61000-3-2
EMI Filtering:	Meets CISPR 11 and 22 and FCC Part 15 Class B (conducted)
Input Protection:	Internal AC line fuse; 250 VAC, 4.0A
Output Power:	160W with 20CFM air; 80W Convection cooled (consult factory for current ratings)
Line Regulation:	± 0.3%
Load Regulation:	± 1% for V1 and V2 ± 7% for V3; ± 5% for V4
PARD:	Greater of 1% or 50mV 20MHz bandwidth
Hold-up Time:	>20 ms @ full load
Turn-on Delay:	<2 seconds
Output Polarity:	See Voltage Chart
Minimum Load:	10% for V1 and V2 5% for V3 and V4
Transient Response:	Greater of 150mV or 3% for 25% load change @ 1A/μs (V1 and V2)

Output Rise Time:	<100 ms (10% to 90%)
Remote Sense:	Standard on V1 and V2 Up to 400mV of cable drop
AC Power Fail:	TTL _{LOW} logic "0" at least 5 ms before DC output drops 5% (without signal jitter). <10mA sink current for Power Fail "0". <1mA source current for Power Fail "1".
Overshoot/Undershoot:	<5% overshoot with remote sense at output terminals
Current Share (option):	Load currents of V1 and V2 for similar units can be shared @ ±5% of total load
Overvoltage Protect:	Factory set, 125% ±5% on V1 and V2 cycle AC to reset
Short Circuit Protection:	All outputs are auto recovery
Reverse Voltage:	Reverse current up to rated outputs
Case Power Protection:	Standard operation interrupt (hiccup mode)
Efficiency:	Up to 88%
MTBF:	MIL-STD-HDBK 217E >200,000 hours @ 25°C Highly Accelerated Life Testing

Available Voltage Outputs*

Voltage Codes	V1 Voltages (Volts)	V1 Currents (Amps)	V2 Voltages (Volts)	V2 Currents (Amps)	V3 Voltages (Volts)	V3 Currents (Amps)	V4** Voltages (Volts)	V4 Currents (Amps)
-1	+1.8	16	+1.8	14	+1.8	3	-1.8	2
-2	+3.3	16	+3.3	14	+3.3	3	-3.3	2
-3	+5	16	+5	14	+5	3	-5	2
-4	+12	6	+12	6	+12	3	-12	2
-5	+15	5	+15	5	+15	2.5	-15	2
-6			+24	3	+24	1.75	-24	1.5
-7			+28	2.5	+28	1.5	-28	1
-8			+36	2	+36	1.5	-36	1
-9			+48	1.5	+48	1	-48	1

* Consult factory for other voltages and OEM quantities.

** Standard Polarity for V4 is negative (-). V4 is available with positive polarity as a Tailored or Custom model.

Note: Standard models are 3244, 3255, 3264, 3404 and 3464

PART # STRUCTURE:

MODEL - VOLTAGE CODE - OPTION CODES (See back)
- V1 V2 V3 V4 -
AAD160 - X X X X - ABC....

Example: Model Number **AAD160-3244-AM** = 160W Power Factor Corrected, (V1) +5V @ 16A, (V2) +3.3V @ 14A, (V3) +12V @ 3A and (V4) -12V @ 2A with Current Sharing and Metric Mounting.
SEE 3rd page for AAD160 CODE TABLE AND AVAILABLE OPTIONS.



Model
AAD160
Options (code)

- #6-32 PEM Nut (Standard)
- PF Invert (B)
- Metric Mounting (M)
- Input and Options with Gold Pins (G)
- Molex Output Connector with Gold Pins (J)
- Molex Connectors with Standard Pins (K)
- Current Sharing (A)
- Thru-Hole Mounting (C)
- PF Open Collector (O)

Surge & ESD Test Levels

- EN61000-4-5 Level 3
- EN61000-3-2
- EN61000-4-4 Level 3
- Meets Class B conducted limits per CISPR 11/22 and 47 CFR 15 subpt B
- EN61000-4-2 Level 2
- EN61000-4-2 Level 3 (Air Only)
- EN61000-4-11

Safety Compliance

- IEC / EN / UL / CSA 60950-1
- CE declaration to Low Voltage Directive 2006/95/EC and
- RoHS Directive 2011/65/EU

Physical Specifications

- Dimensions: (HxWxL) 1.25" x 3.14" x 5"
- Operating Temp: 0 to 50°C; rated power to 50°C with 20CFM air
- Relative Humidity: 5% to 90%, non-condensing
- Storage: -50 to 85°C/20-90% RH
- Altitude: 6561 40,000' storage

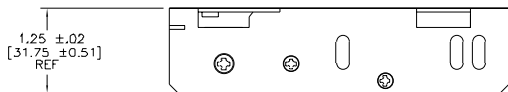
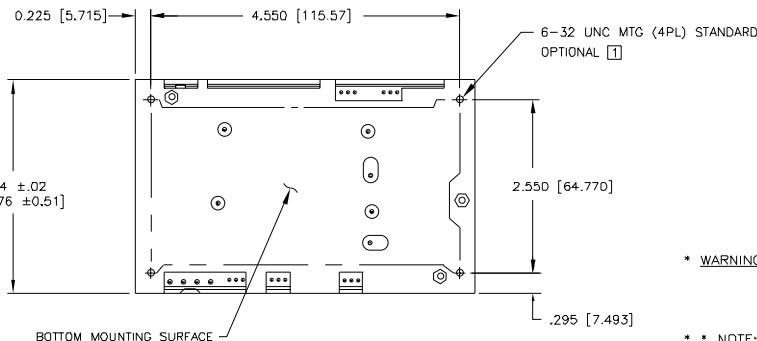
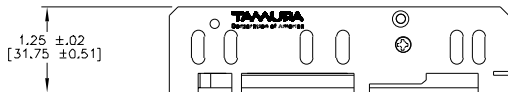
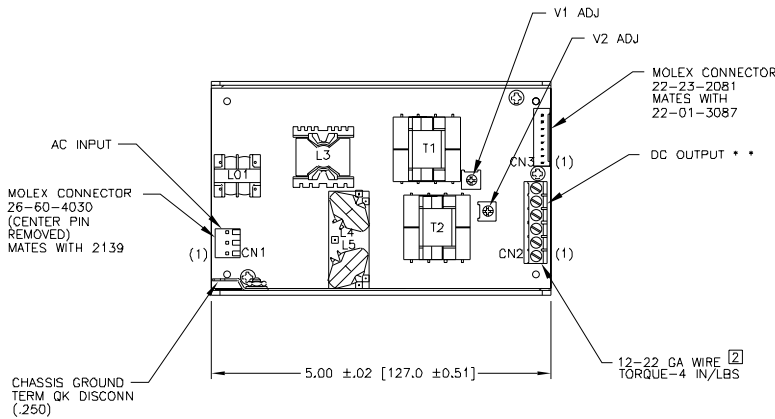

PIN NO.	CN1
1	AC LINE
2	
3	NEUTRAL

MOLEX CONNECTOR
26-60-4030
CENTER PIN
REMOVED

PIN NO.	CN2	
1	V3	**
2	V2	**
3	RTN	
4	RTN	
5	V1	**
6	V4	**

FOR
12-22 GA WIRE
TORQUE-4 IN/LBS

PIN NO.	CN3	
1	V2 CURRENT SHARE	
2	V1 CURRENT SHARE	
3	POWER FAIL	
4	RTN	
5	V1 -REMOTE SENSE	*
6	V1 +REMOTE SENSE	*
7	V2 +REMOTE SENSE	*
8	V2 -REMOTE SENSE	*

MOLEX CONNECTOR
22-23-2081

UNIT WEIGHT	
0.72 LBS	

* **WARNING:** DAMAGE WILL OCCUR IF REMOTE SENSE LEADS ARE REVERSED OR USED WITH LOAD DISCONNECTED FROM RESPECTIVE OUTPUTS.

* **NOTE:** FOR PROPER REGULATION MINIMUM LOADS ARE REQUIRED, 0.5A FOR V1 AND V2, 0.1A FOR V3 AND V4

[2] OPTIONAL- MOLEX CONNECTOR LIMITED TO 7A FOR V1, V2 OUTPUT

[1] OPTIONAL- #6 CLEARANCE HOLE PROVIDED THROUGH THE BOARD AND CHASSIS FOR TOP SIDE MOUNTING OF POWER SUPPLY.

NOTES: UNLESS OTHERWISE SPECIFIED.



PRODUCT CODE TABLE RoHS

AAD160 Series Part Number Code Table

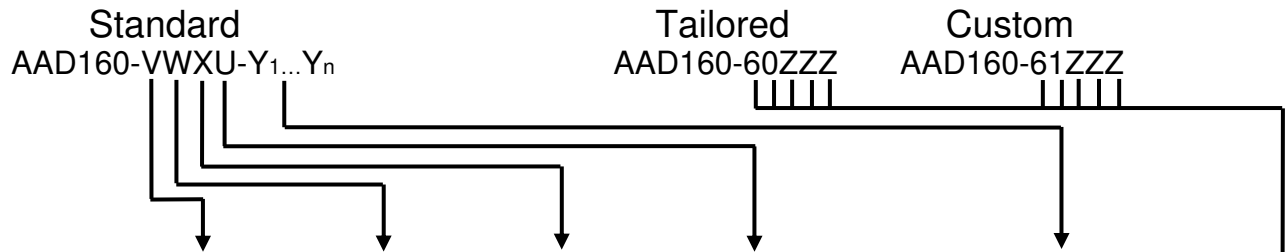

	Rated Voltages and Currents (1) (2) (3)								Standard Options
Voltage Codes	"V" Output (V1)		"W" Output (V2)		"X" Output (V3)		"U" Output (V4)		"Y" Codes
	Volts	Amps	Volts	Amps	Volts	Amps	Volts	Amps	
1	+1.8	16	+1.8	14	+1.8	3	-1.8	2	A = Current Share B = PF Invert C = Thru-Hole Mounting* G = Input and Option Connectors with Gold Pins J = Molex Output Connector with Gold Pins** K = Molex Output Connector with Standard Pins** M = Metric Pemnut Mounting* O = PF Open Collector * Pemnut chassis mounting is standard **7A MAX current for V1, V2
2	+3.3	16	+3.3	14	+3.3	3	-3.3	2	
3	+5	16	+5	14	+5	3	-5	2	
4	+12	6	+12	6	+12	3	-12	2	
5	+15	5	+15	5	+15	2.5	-15	2	
6	Not Available		+24	3	+24	1.75	-24	1.5	
7	Not Available		+28	2.5	+28	1.5	-28	1	
8	Not Available		+36	2	+36	1.5	-36	1	
9	Not Available		+48	1.5	+48	1	-48	1	
0	Not Used		Not Used		Not Used		Not Used		
Notes: 1. Polarities are with respect to a common return. 2. V4 is available with positive (+) polarity as Tailored or Custom Model. 3. V4 is slaved to V1. V3 is slaved to V2. Restrictions: 1. For V2 > +15V, V3 must be +5V to +15V or Not Used. 2. Voltage differential between V1 and V4 may not exceed 60Vrms (S.E.L.V.). 3. Current Share is available for 1.8V, 3.3V, 5V and 12V V1 and V2 only. V4 and V3 (respectively) must also be 28V or less.									
Tailored Models (No Safety Impact) ----- 60ZZZ, where ZZZ = Factory Assigned Number. Harnesses, special test data or other modifications made to a standard model.									
Custom Models (Safety Evaluation and/or Review Required) ----- 61ZZZ, where ZZZ = Factory Assigned Number.									