

PART NUMBER
10120045-401LF

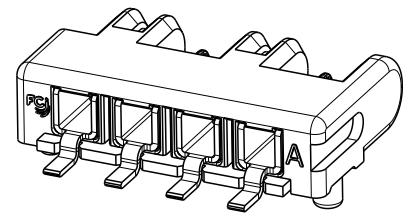

SCALE 3.000

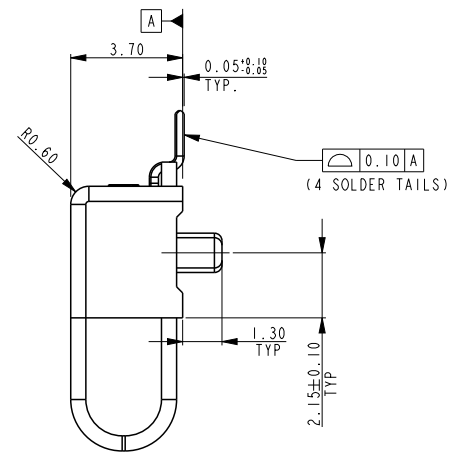
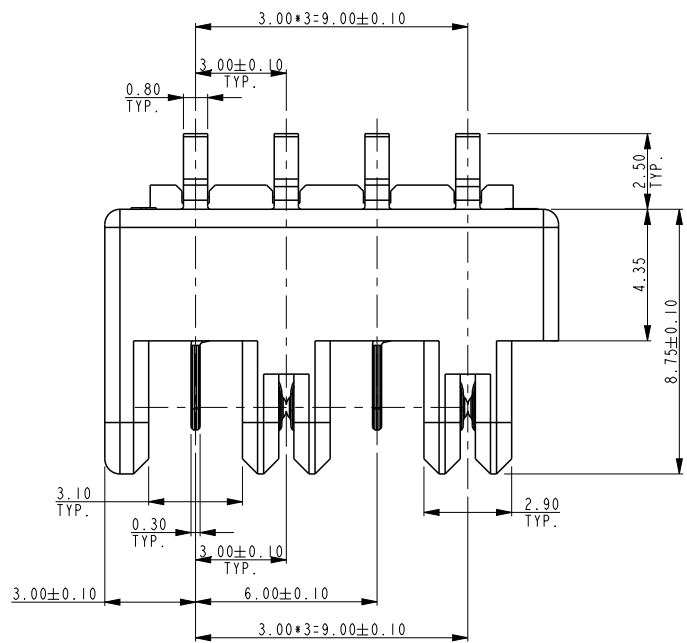
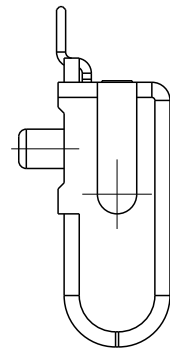
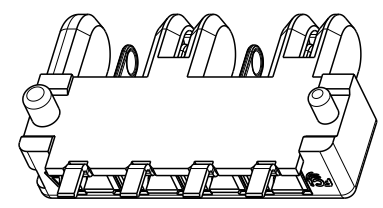

SCALE 3.000

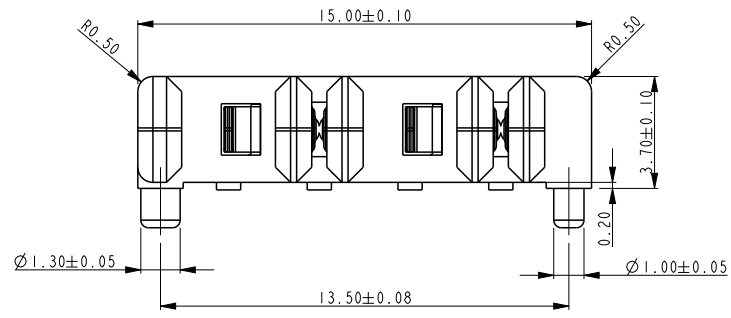

SCALE 4.000

NOTES:
1. MATERIAL
HOUSING: HIGH TEMPERATURE THERMOPLASTIC POLYESTER
UL 94 V-0, NATURAL
CONTACTS: COPPER ALLOY;
PLATING SPEC AS BELOW:
FOR CONTACT AREA:
*GXT OVER NICKEL
FOR SOLDER AREA:
TIN (MATTE) OVER NICKEL
2. PRODUCT SPEC. GS-12-1079
3. LEAD FREE NOTES:
3a. THE HOUSING WILL WITHSTAND EXPOSURE TO 260° C PEAK
TEMPERATURE FOR 10 SECONDS IN A COVECTION, INFRA-RED
OR VAPOR PHASE REFLOW OVEN.
3b. THIS PRODUCT MEETS EUROPEAN UNION DIRECTIVES AND
OTHER COUNTRY REGULATIONS AS DESCRIBED IN GS-22-008.
*GXT™ is an FCI Electronics patented process of palladium-nickel alloy plated with a gold flash.



Copyright FCI.

| | | | | | | |
|--------------------|-------------|------------|------------------------------|---|---|---------------|
| www.fciconnect.com | | | surface ISO 1302 | tolerance std ISO 406 ISO 1101 | projection TOLERANCES UNLESS OTHERWISE SPECIFIED | MM |
| Dr | M JACOB | 2014-05-12 | ANGULAR | 0.x ±x | size A4 | Scale 4.000 |
| Eng | M JACOB | 2014-05-12 | LINEAR | 0.xx ±0.2 | ECN ELX-1-22313 | |
| Chr | M JACOB | 2014-05-12 | 0° ±2° | 0.xxx ±x | | |
| Appr | BIJU K PAUL | 2014-05-12 | Product family - RoTaConnect | | Spec ref | |
| FCI | | | title | ASSEMBLY, 4 POS HOR TYPE WITH PEG ROTATABLE BOARD TO BOARD CONNECTOR | dwg no | 10120045-401C |
| | | | catalog no | 10120045-401LF | CUSTOMER DRAWING | sheet 1 of 2 |

| rev | ecn no | dr | date |
|-----|-------------|-----|------------|
| A | - | MJA | 2014-05-12 |
| B | ELX-1-22313 | MJA | 2015-10-27 |
| - | - | - | - |
| - | - | - | - |
| - | - | - | - |
| - | - | - | - |

PART NUMBER
10120045-401LF

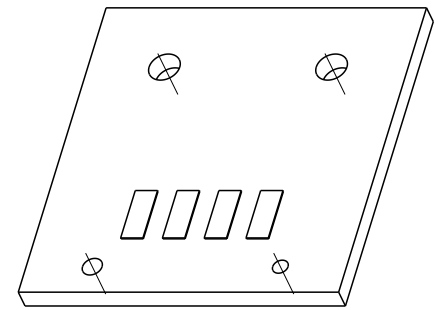
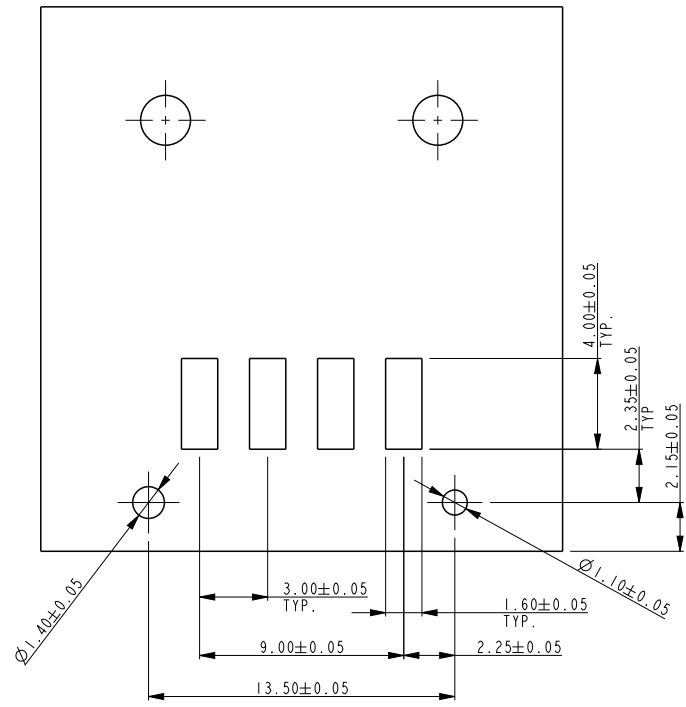

SCALE 2.000

SCALE 3.000



Copyright FCI.

REV F - 2006-04-17

| rev | ecn no | dr | date |
|-----|--------|----|------|
| B | - | - | - |
| - | - | - | - |
| - | - | - | - |
| - | - | - | - |
| - | - | - | - |
| - | - | - | - |

| | | | | | | |
|--------------------|-------------|------------|---------------------------------------|-----------------------------------|------------------------|---|
| www.fciconnect.com | | | surface ISO 1302 | tolerance std ISO 406 ISO 1101 | projection ISO 1101 | MM |
| | | | TOLERANCES UNLESS OTHERWISE SPECIFIED | | | |
| Dr | M JACOB | 2014-05-12 | ANGULAR | LINEAR | 0.x | ±x |
| Eng | M JACOB | 2014-05-12 | | | 0.xx | ±0.2 |
| Chr | M JACOB | 2014-05-12 | 0° | ±2° | 0.xxx | ±x |
| Appr | BIJU K PAUL | 2014-05-12 | Product family - RotaConnect | | size | A4 |
| | | | Spec ref | | Scale | 1.000 |
| | | | | | ECN | ELX-1-22313 |
| | | | | | title | ASSEMBLY, 4 POS HOR TYPE WITH PEG ROTATABLE BOARD TO BOARD CONNECTOR |
| | | | | | dwg no | 10120045-401C |
| | | | | | Rev. | B |
| | | | catalog no | | 10120045-401LF | CUSTOMER DRAWING |
| | | | | | sheet 2 of 2 | |

PART NUMBER
10120045-401LF

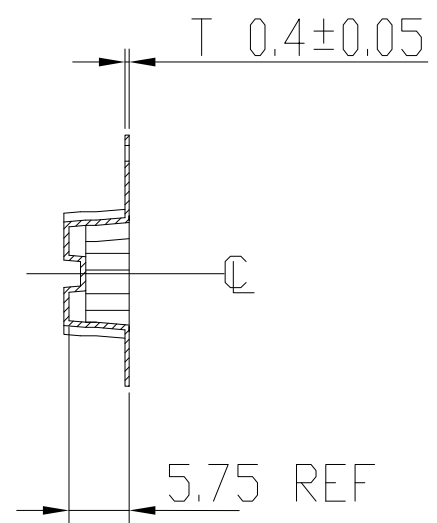

SECTION A-A

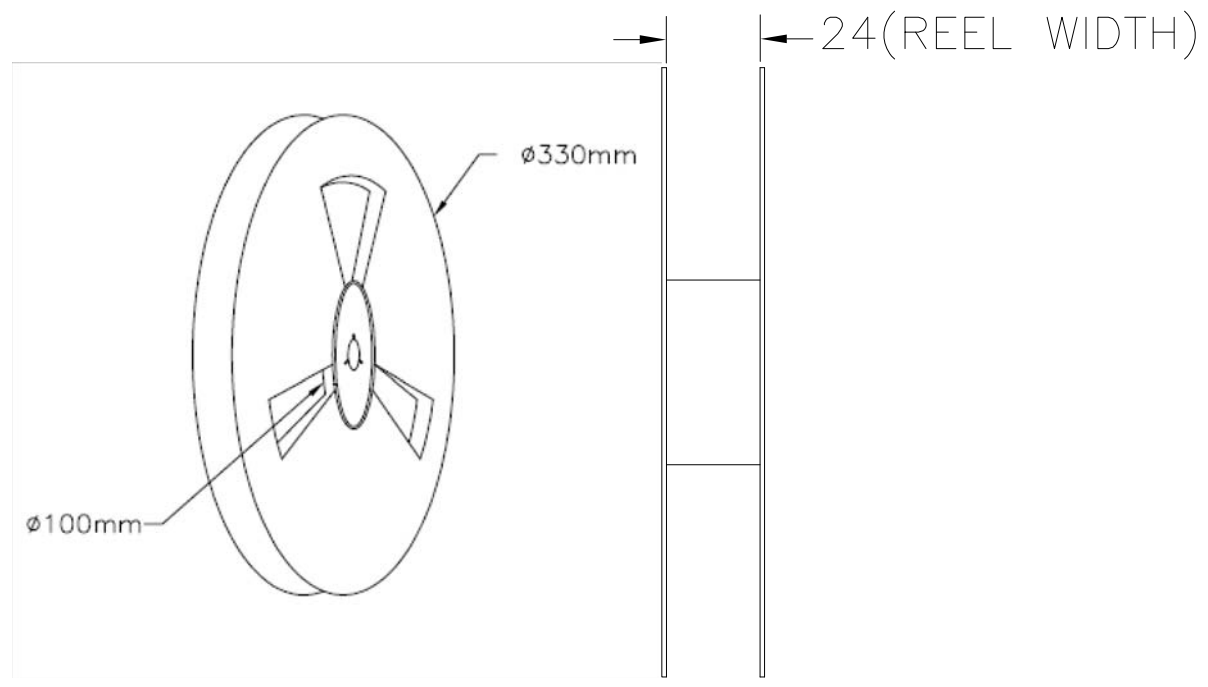
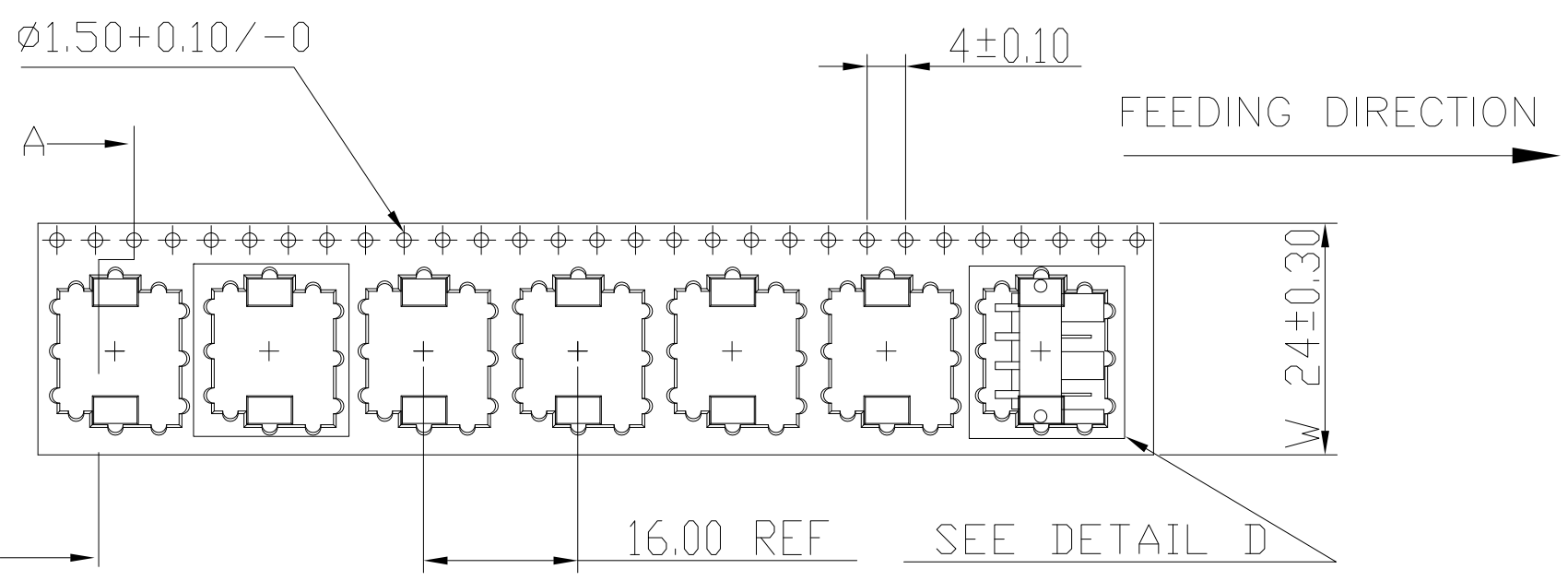

Component inside carrier tape

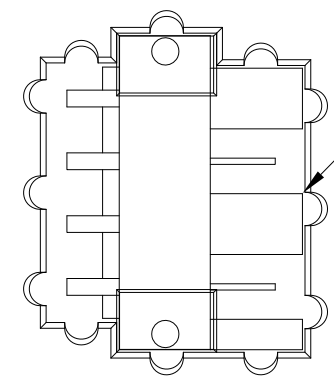

DETAIL D
SCALE 2:1

NOTES :

1. MATERIAL : ANTI-STATIC POLYSTYRENE
2. PACKAGING AS PER EIA-481 STD.
3. QTY PER REEL : 710 NOS

| rev | ecn no | dr | date |
|-----|--------|----|------|
| B | - | - | - |
| - | - | - | - |
| - | - | - | - |
| - | - | - | - |
| - | - | - | - |

| | | | | | |
|--------------------|-------------|------------|---|-----------------------------------|--------------------------------|
| www.fciconnect.com | | | surface ISO 1302 | tolerance std ISO 406 ISO 1101 | projection MM |
| | | | TOLERANCES UNLESS OTHERWISE SPECIFIED | | |
| Dr | M JACOB | 2014-05-12 | ANGULAR | 0.X | ±X |
| Eng | M JACOB | 2014-05-12 | | 0.XX | ±0.2 |
| Chr | M JACOB | 2014-05-12 | 0° ±2° | 0.XXX | ±X |
| Appr | BIJU K PAUL | 2014-05-12 | Product family- RotaConnect | | size A4 |
| | | | ECN ELX-I-22313 | | Scale 1,000 |
| | | | Spec ref - | | |
| | | | title ASSEMBLY, 4 PDS HDR TYPE WITH PEG ROTATABLE BOARD TO BOARD CONNECTOR | | dwg no 10120045-401C Rev. B |
| | | | catalog no : 10120045-401LF | | CUSTOMER DRAWING sheet 3 of 3 |

REV F - 2006-04-17