





# 140×140×38 mm

San Ace 140W 9W type   

## General Specifications

- Material ..... Frame: Aluminum (Black coating), Impeller: Plastic (Flammability: UL 94V-1)
- Expected life ..... See the table below. (L10 life: 90% survival rate for continuous operation in indoor free air at 60°C, rated voltage)
- Motor protection function ..... Locked rotor burnout protection, Reverse polarity protection  
For details, please refer to p. 529.
- Dielectric strength ..... 50/60 Hz, 500 VAC, for 1 minute (between lead wire conductors and frame)
- Insulation resistance ..... 10 MΩ or more with a 500 VDC megger (between lead wire conductors and frame)
- Sound pressure level (SPL) ..... At 1 m away from the air inlet
- Storage temperature ..... -30 to +70°C (Non-condensing)
- Lead wire ..... ⊕Red ⊖Black or Blue (Sensor) Yellow
- Mass ..... 650 g
- Ingress protection ..... IP68

## Specifications

The models listed below **have pulse sensors**.

Model no.	Rated voltage [V]	Operating voltage range [V]	Rated current [A]	Rated input [W]	Rated speed [min <sup>-1</sup> ]	Max. airflow [m <sup>3</sup> /min] [CFM]	Max. static pressure [Pa] [inchH <sub>2</sub> O]	SPL [dB (A)]	Operating temperature [°C]	Expected life [h]
109W1412H101-U	12	10.2 to 13.8	0.73	8.76	2600	4.5 159	98 0.394	46	-20 to +70	100000/60°C
109W1412M101-U			0.3	3.6	1900	3.3 117	52 0.209	38		
109W1424H101-U	24	20.4 to 27.6	0.37	8.88	2600	4.5 159	98 0.394	46		
109W1424M101-U			0.16	3.84	1900	3.3 117	52 0.209	38		
109W1448H101-U	48	40.8 to 55.2	0.2	9.6	2600	4.6 159	98 0.394	46		
109W1448M101-U			0.09	4.32	1900	3.3 117	52 0.209	38		

Other sensor specifications are available as options. Refer to the index (p. 546).

## Airflow - Static Pressure Characteristics

**109W1412H101-U** With pulse sensor

Operating voltage range

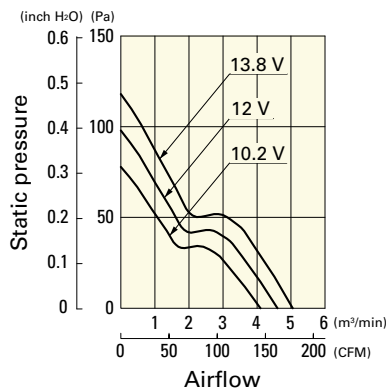

**109W1412M101-U** With pulse sensor

Operating voltage range

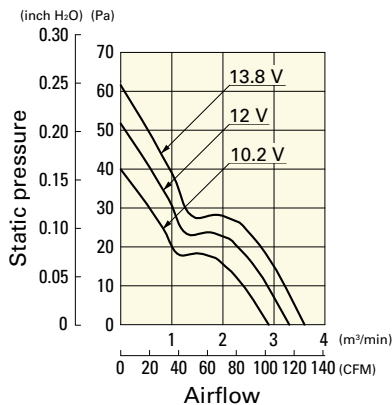

**109W1424H101-U** With pulse sensor

Operating voltage range

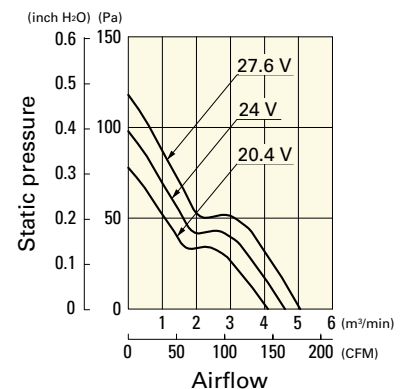

## Airflow - Static Pressure Characteristics

**109W1424M101-U** With pulse sensor

Operating voltage range

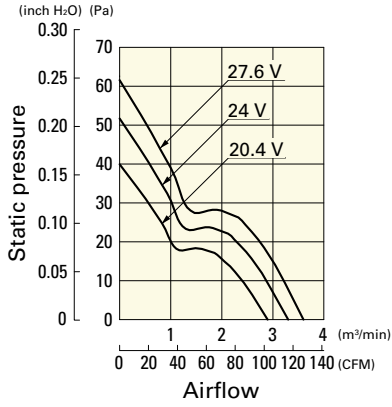

**109W1448H101-U** With pulse sensor

Operating voltage range

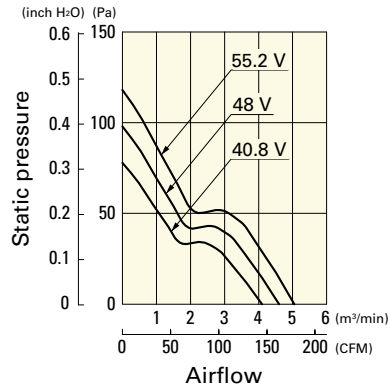

**109W1448M101-U** With pulse sensor

Operating voltage range

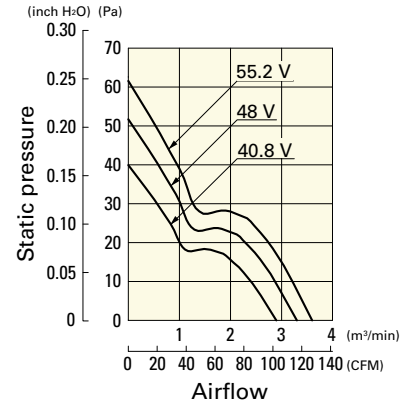

## Dimensions (unit: mm)

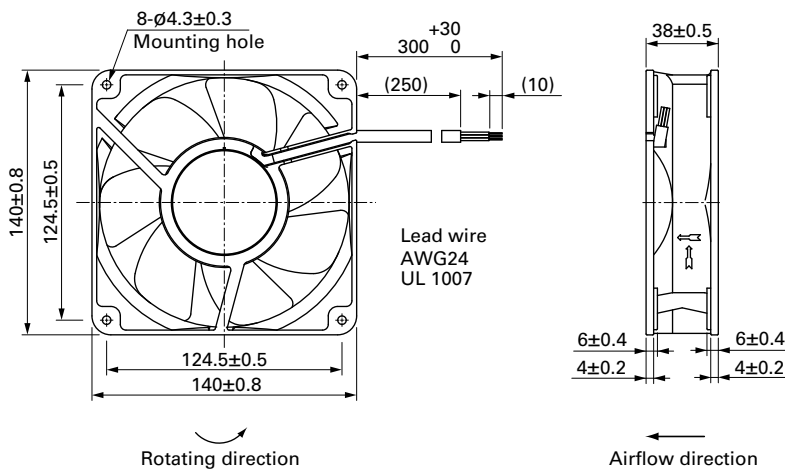

## Reference Dimensions of Mounting Holes and Vent Opening (unit: mm)

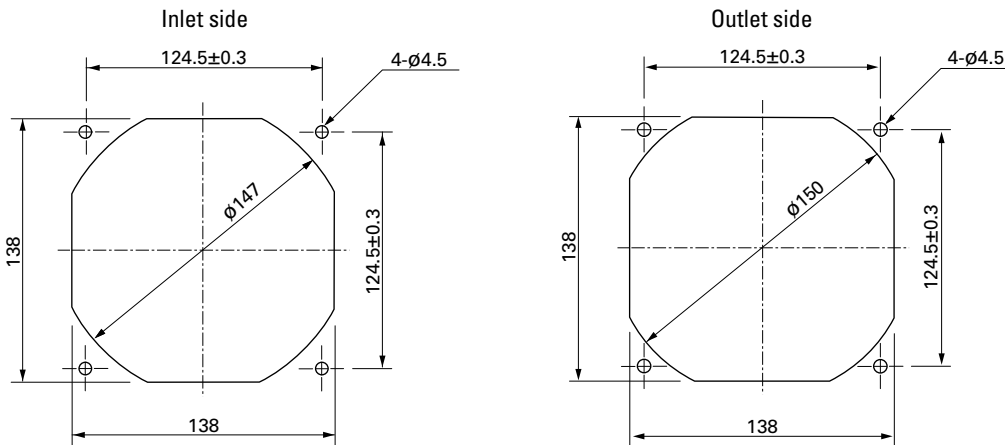

## Options

Finger guards

page: p. 514

Model no.: 109-719, 109-719H