

## AM26C32 Quadruple Differential Line Receiver

### 1 Features

- Meets or Exceeds the Requirements of ANSI TIA/EIA-422-B, TIA/EIA-423-B, and ITU Recommendation V.10 and V.11
- Low Power,  $I_{CC} = 10$  mA Typical
- $\pm 7$ -V Common-Mode Range With  $\pm 200$ -mV Sensitivity
- Input Hysteresis: 60 mV Typical
- $t_{pd} = 17$  ns Typical
- Operates From a Single 5-V Supply
- 3-State Outputs
- Input Fail-Safe Circuitry
- Improved Replacements for AM26LS32 Device
- Available in Q-Temp Automotive

### 2 Applications

- High-Reliability Automotive Applications
- Factory Automation
- ATM and Cash Counters
- Smart Grid
- AC and Servo Motor Drives

### 3 Description

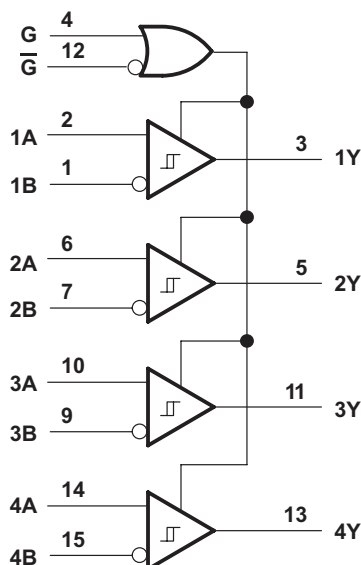
The AM26C32 device is a quadruple differential line receiver for balanced or unbalanced digital data transmission. The enable function is common to all four receivers and offers a choice of active-high or active-low input. The 3-state outputs permit connection directly to a bus-organized system. Fail-safe design specifies that if the inputs are open, the outputs always are high. The AM26C32 devices are manufactured using a BiCMOS process, which is a combination of bipolar and CMOS transistors. This process provides the high voltage and current of bipolar with the low power of CMOS to reduce the power consumption to about one-fifth that of the standard AM26LS32, while maintaining AC and DC performance.

#### Device Information<sup>(1)</sup>

PART NUMBER	PACKAGE	BODY SIZE (NOM)
AM26C32N	PDIP (16)	19.30 mm × 6.35 mm
AM26C32NS	SO (16)	10.20 mm × 5.30 mm
AM26C32D	SOIC (16)	9.90 mm × 3.90 mm
AM26C32PW	TSSOP (16)	5.00 mm × 4.40 mm
AM26C32J	CDIP (16)	21.34 mm × 6.92 mm
AM26C32W	CFP (16)	10.16 mm × 6.73 mm
AM26C32FK	LCCC (20)	8.90 mm × 8.90 mm

(1) For all available packages, see the orderable addendum at the end of the data sheet.

#### Simplified Schematic



## Table of Contents

<b>1 Features</b> .....	1	8.3 Feature Description .....	8
<b>2 Applications</b> .....	1	8.4 Device Functional Modes .....	9
<b>3 Description</b> .....	1	<b>9 Application and Implementation</b> .....	10
<b>4 Revision History</b> .....	2	9.1 Application Information .....	10
<b>5 Pin Configuration and Functions</b> .....	3	9.2 Typical Application .....	10
<b>6 Specifications</b> .....	4	<b>10 Power Supply Recommendations</b> .....	12
6.1 Absolute Maximum Ratings .....	4	<b>11 Layout</b> .....	12
6.2 ESD Ratings .....	4	11.1 Layout Guidelines .....	12
6.3 Recommended Operating Conditions .....	4	11.2 Layout Example .....	12
6.4 Thermal Information .....	4	<b>12 Device and Documentation Support</b> .....	13
6.5 Electrical Characteristics .....	5	12.1 Receiving Notification of Documentation Updates .....	13
6.6 Switching Characteristics .....	5	12.2 Community Resources .....	13
6.7 Typical Characteristics .....	6	12.3 Trademarks .....	13
<b>7 Parameter Measurement Information</b> .....	7	12.4 Electrostatic Discharge Caution .....	13
<b>8 Detailed Description</b> .....	8	12.5 Glossary .....	13
8.1 Overview .....	8	<b>13 Mechanical, Packaging, and Orderable Information</b> .....	13
8.2 Functional Block Diagram .....	8		

## 4 Revision History

### Changes from Revision K (June 2015) to Revision L Page

- Changed  $I_I$  unit value From:  $\mu\text{A}$  To:  $\text{mA}$  in the *Electrical Characteristics* table ..... 5

### Changes from Revision J (February 2014) to Revision K Page

- Added *Pin Configuration and Functions* section, *ESD Ratings* table, *Feature Description* section, *Device Functional Modes*, *Application and Implementation* section, *Power Supply Recommendations* section, *Layout* section, *Device and Documentation Support* section, and *Mechanical, Packaging, and Orderable Information* section ..... 1

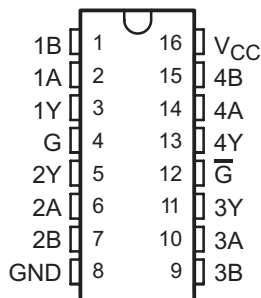
### Changes from Revision I (September 2004) to Revision J Page

- Updated document to new TI data sheet format - no specification changes ..... 1
- Deleted *Ordering Information* table. .... 1
- Updated *Features* .....

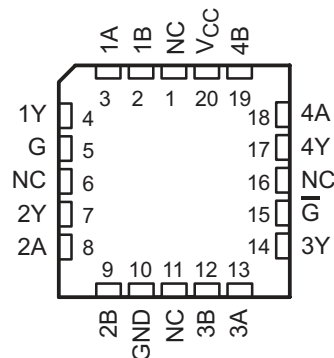
- Added ESD Warning ..... 3

## 5 Pin Configuration and Functions

D, N, NS, PW, J or W Package  
16-Pin SOIC, PDIP, SO, TSSOP, CDIP, or CFP  
Top View



FK Package  
20-Pin LCCC  
Top View



### Pin Functions

NAME	PIN		I/O	DESCRIPTION
	LCCC	SOIC, PDIP, SO, TSSOP, CFP, or CDIP		
1A	3	2	I	RS422/RS485 differential input (noninverting)
1B	2	1	I	RS422/RS485 differential input (inverting)
1Y	4	3	O	Logic level output
2A	8	6	I	RS422/RS485 differential input (noninverting)
2B	9	7	I	RS422/RS485 differential input (inverting)
2Y	7	5	O	Logic level output
3A	13	10	I	RS422/RS485 differential input (noninverting)
3B	12	9	I	RS422/RS485 differential input (inverting)
3Y	14	11	O	Logic level output
4A	18	14	I	RS422/RS485 differential input (noninverting)
4B	19	15	I	RS422/RS485 differential input (inverting)
4Y	17	13	O	Logic level output
G	5	4	I	Active-high select
$\bar{G}$	15	12	I	Active-low select
GND	10	8	—	Ground
NC <sup>(1)</sup>	1	—	—	Do not connect
	6			
	11			
	16			
V <sub>CC</sub>	20	16	—	Power Supply

(1) NC – no internal connection.

## 6 Specifications

### 6.1 Absolute Maximum Ratings

 over operating free-air temperature range (unless otherwise noted) <sup>(1)</sup>

		MIN	MAX	UNIT	
V <sub>CC</sub>	Supply voltage <sup>(2)</sup>		7	V	
V <sub>I</sub>	Input voltage	A or B inputs	-11	14	V
		G or $\bar{G}$ inputs	-0.5	V <sub>CC</sub> + 0.5	
V <sub>ID</sub>	Differential input voltage	-14	14	V	
V <sub>O</sub>	Output voltage	-0.5	V <sub>CC</sub> + 0.5	V	
I <sub>O</sub>	Output current		±25	mA	
T <sub>stg</sub>	Storage temperature	-65	150	°C	

- (1) Stresses beyond those listed under *Absolute Maximum Ratings* may cause permanent damage to the device. These are stress ratings only, which do not imply functional operation of the device at these or any other conditions beyond those indicated under *Recommended Operating Conditions*. Exposure to absolute-maximum-rated conditions for extended periods may affect device reliability.
- (2) All voltage values, except differential voltages, are with respect to the network ground terminal.

### 6.2 ESD Ratings

		VALUE	UNIT	
V <sub>(ESD)</sub>	Electrostatic discharge	Human body model (HBM), per ANSI/ESDA/JEDEC JS-001 <sup>(1)</sup>	±3000	V
		Charged-device model (CDM), per JEDEC specification JESD22-C101 <sup>(2)</sup>	±2000	

- (1) JEDEC document JEP155 states that 500-V HBM allows safe manufacturing with a standard ESD control process.
- (2) JEDEC document JEP157 states that 250-V CDM allows safe manufacturing with a standard ESD control process.

### 6.3 Recommended Operating Conditions

over operating free-air temperature range (unless otherwise noted)

		MIN	NOM	MAX	UNIT
V <sub>CC</sub>	Supply voltage	4.5	5	5.5	V
V <sub>IH</sub>	High-level input voltage	2		V <sub>CC</sub>	V
V <sub>IL</sub>	Low-level input voltage	0		0.8	V
V <sub>IC</sub>	Common-mode input voltage	-7		+7	V
I <sub>OH</sub>	High-level output current			-6	mA
I <sub>OL</sub>	Low-level output current			6	mA
T <sub>A</sub>	Operating free-air temperature	AM26C32C		70	°C
		AM26C32I	-40	85	
		AM26C32Q	-40	125	
		AM26C32M	-55	125	

### 6.4 Thermal Information

THERMAL METRIC <sup>(1)</sup>	AM26C32				UNIT	
	D (SOIC)	N (PDIP)	NS (SO)	PW (TSSOP)		
	16 PINS	16 PINS	16 PINS	16 PINS		
R <sub>θJA</sub>	Junction-to-ambient thermal resistance	73	67	64	108	°C/W

- (1) For more information about traditional and new thermal metrics, see the *Semiconductor and IC Package Thermal Metrics* application report, [SPRA953](#).

## 6.5 Electrical Characteristics

over operating free-air temperature range (unless otherwise noted)

PARAMETER		TEST CONDITIONS		MIN	TYP <sup>(1)</sup>	MAX	UNIT
V <sub>IT+</sub>	Differential input high-threshold voltage	V <sub>O</sub> = V <sub>OH(min)</sub> , I <sub>OH</sub> = -440 μA	V <sub>IC</sub> = -7 V to 7 V			0.2	V
			V <sub>IC</sub> = 0 V to 5.5 V			0.1	
V <sub>IT-</sub>	Differential input low-threshold voltage	V <sub>O</sub> = 0.45 V, I <sub>OL</sub> = 8 mA	V <sub>IC</sub> = -7 V to 7 V			-0.2 <sup>(2)</sup>	V
			V <sub>IC</sub> = 0 V to 5.5 V			-0.1 <sup>(2)</sup>	
V <sub>hys</sub>	Hysteresis voltage (V <sub>IT+</sub> - V <sub>IT-</sub> )				60		mV
V <sub>IK</sub>	Enable input clamp voltage	V <sub>CC</sub> = 4.5 V, I <sub>I</sub> = -18 mA				-1.5	V
V <sub>OH</sub>	High-level output voltage	V <sub>ID</sub> = 200 mV, I <sub>OH</sub> = -6 mA		3.8			V
V <sub>OL</sub>	Low-level output voltage	V <sub>ID</sub> = -200 mV, I <sub>OL</sub> = 6 mA			0.2	0.3	V
I <sub>OZ</sub>	OFF-state (high-impedance state) output current	V <sub>O</sub> = V <sub>CC</sub> or GND			±0.5	±5	μA
I <sub>I</sub>	Line input current	V <sub>I</sub> = 10 V, Other input at 0 V				1.5	mA
		V <sub>I</sub> = -10 V, Other input at 0 V				-2.5	
I <sub>IH</sub>	High-level enable current	V <sub>I</sub> = 2.7 V				20	μA
I <sub>IL</sub>	Low-level enable current	V <sub>I</sub> = 0.4 V				-100	μA
r <sub>i</sub>	Input resistance	One input to ground		12	17		kΩ
I <sub>CC</sub>	Quiescent supply current	V <sub>CC</sub> = 5.5 V			10	15	mA

(1) All typical values are at V<sub>CC</sub> = 5 V, V<sub>IC</sub> = 0, and T<sub>A</sub> = 25°C.

(2) The algebraic convention, in which the less positive (more negative) limit is designated minimum, is used in this data sheet for common-mode input voltage.

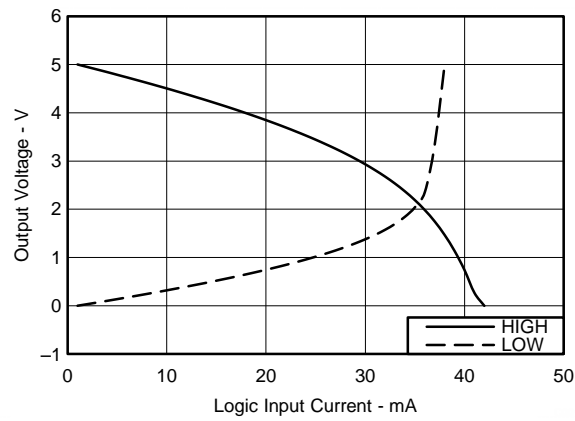
## 6.6 Switching Characteristics

over operating free-air temperature range, C<sub>L</sub> = 50 pF (unless otherwise noted)

PARAMETER	TEST CONDITIONS	AM26C32C AM26C32I			AM26C32Q AM26C32M			UNIT	
		MIN	TYP <sup>(1)</sup>	MAX	MIN	TYP <sup>(1)</sup>	MAX		
t <sub>PLH</sub>	Propagation delay time, low- to high-level output	See Figure 2	9	17	27	9	17	27	ns
t <sub>PHL</sub>	Propagation delay time, high- to low-level output		9	17	27	9	17	27	
t <sub>TLH</sub>	Output transition time, low- to high-level output	See Figure 2		4	9		4	10	ns
t <sub>THL</sub>	Output transition time, high- to low-level output			4	9		4	9	
t <sub>PZH</sub>	Output enable time to high-level	See Figure 3		13	22		13	22	ns
t <sub>PZL</sub>	Output enable time to low-level			13	22		13	22	
t <sub>PHZ</sub>	Output disable time from high-level	See Figure 3		13	22		13	26	ns
t <sub>PLZ</sub>	Output disable time from low-level			13	22		13	25	

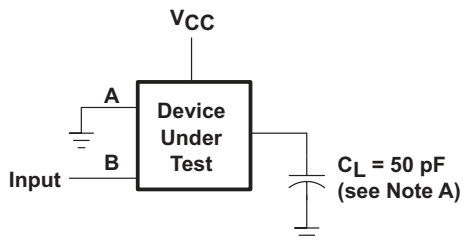
(1) All typical values are at V<sub>CC</sub> = 5 V, T<sub>A</sub> = 25°C.

## 6.7 Typical Characteristics

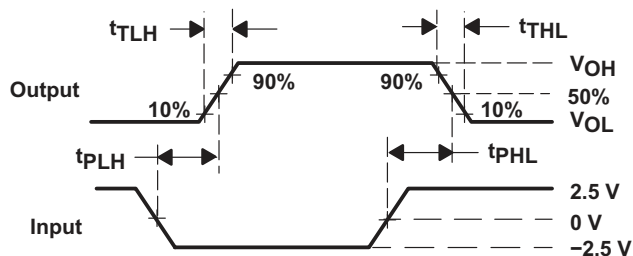


**Figure 1. Output Voltage vs Input Current**

## 7 Parameter Measurement Information



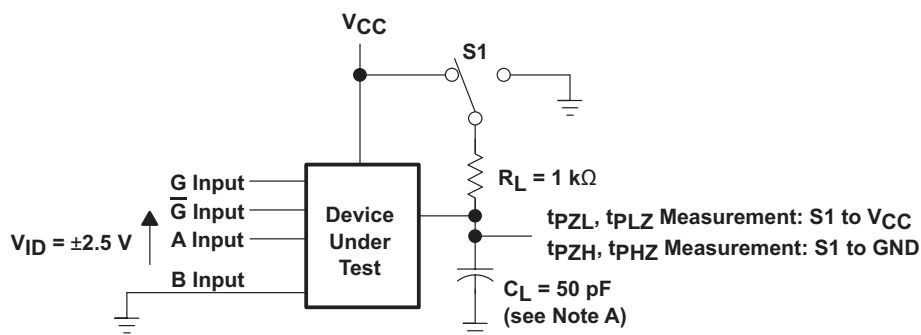
TEST CIRCUIT



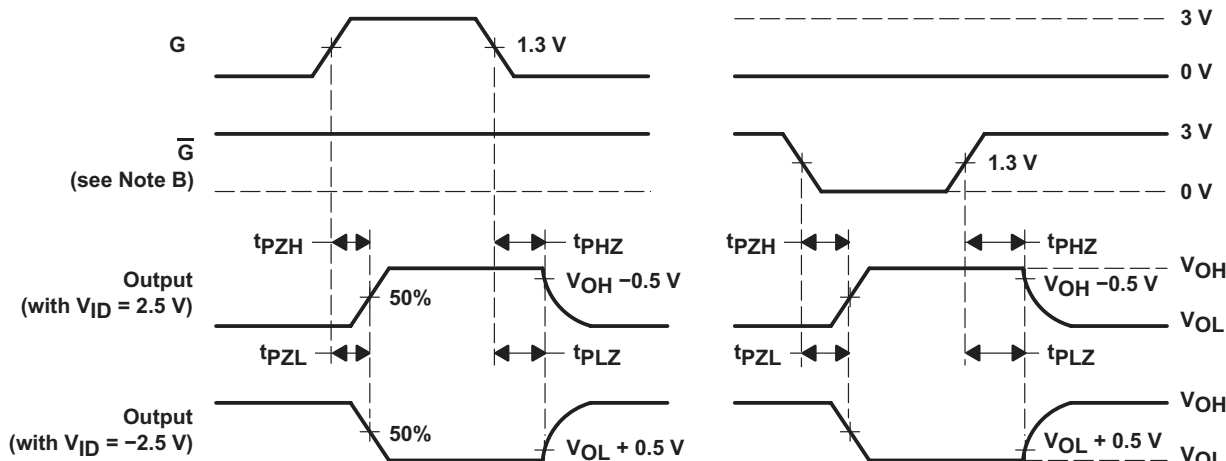
VOLTAGE WAVEFORMS

A.  $C_L$  includes probe and jig capacitance.

Figure 2. Switching Test Circuit and Voltage Waveforms



TEST CIRCUIT



VOLTAGE WAVEFORMS

A.  $C_L$  includes probe and jig capacitance.

B. The input pulse is supplied by a generator having the following characteristics: PRR = 1 MHz, duty cycle  $\leq 50\%$ ,  $t_r = t_f = 6 \text{ ns}$ .

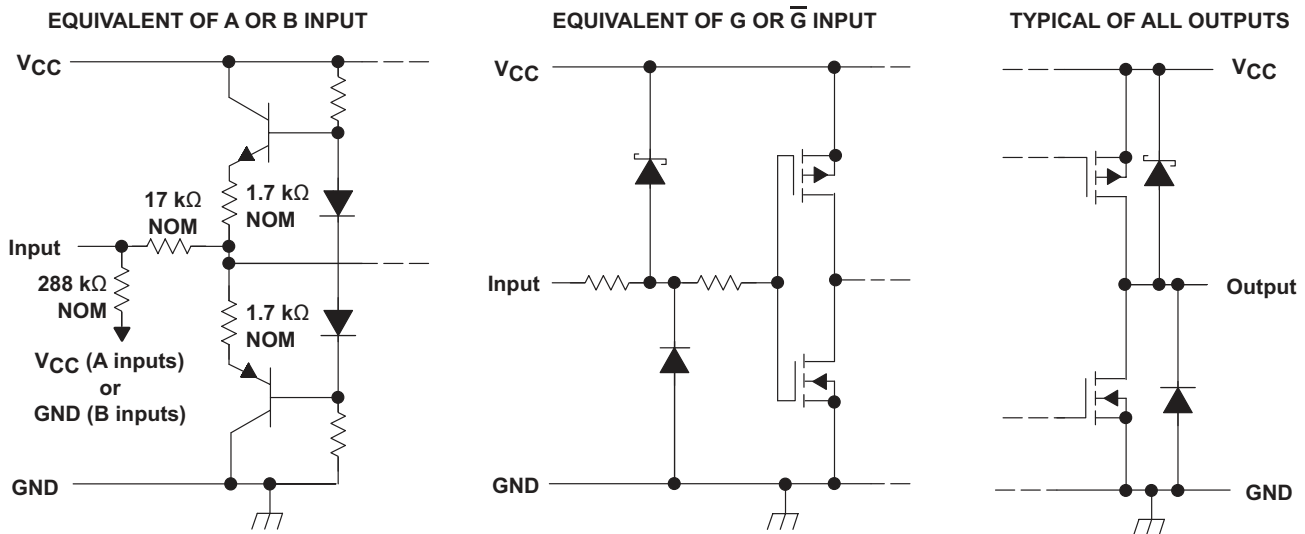
Figure 3. Enable/Disable Time Test Circuit and Output Voltage Waveforms

## 8 Detailed Description

### 8.1 Overview

The AM26C32 is a quadruple differential line receiver that meets the necessary requirements for NSI TIA/EIA-422-B, TIA/EIA-423-B, and ITU Recommendation V.10 and V.11. This device allows a low power or low voltage MCU to interface with heavy machinery, subsystems and other devices through long wires of up to 1000m, giving any design a reliable and easy to use connection. As any RS422 interface, the AM26C32 works in a differential voltage range, which enables very good signal integrity.

### 8.2 Functional Block Diagram



### 8.3 Feature Description

#### 8.3.1 $\pm 7$ -V Common-Mode Range With $\pm 200$ -mV Sensitivity

For a common-mode voltage varying from -7V to 7V, the input voltage is acceptable in low ranges greater than 200 mV as a standard.

#### 8.3.2 Input Fail-Safe Circuitry

RS-485 specifies that the receiver output state should be logic high for differential input voltages of  $V_{AB} \geq +200$  mV and logic low for  $V_{AB} \leq -200$  mV. For input voltages in between these limits, a receiver's output state is not defined and can randomly assume high or low. Removing the uncertainty of random output states, modern transceiver designs include internal biasing circuits that put the receiver output into a defined state (typically high) in the absence of a valid input signal.

A loss of input signal can be caused by an open circuit caused by a wire break or the unintentional disconnection of a transceiver from the bus. The AM26C32 has an internal circuit that ensures functionality during an idle bus.

#### 8.3.3 Active-High and Active-Low

The device can be configured using the G and  $\bar{G}$  logic inputs to select receiver output. The high voltage or logic 1 on the G pin, allows the device to operate on an active-high and having a low voltage or logic 0 on the  $\bar{G}$  enables active low operation. These are simply a way to configure the logic to match that of the receiving or transmitting controller or microprocessor.

#### 8.3.4 Operates from a Single 5-V Supply

Both the logic and receivers operate from a single 5-V rail, making designs much more simple. The line drivers and receivers can operate off the same rail as the host controller or a similar low voltage supply, thus simplifying power structure.



## 8.4 Device Functional Modes

### 8.4.1 Enable and Disable

The receivers implemented in these RS422 devices can be configured using the G and  $\bar{G}$  pins to be enabled or disabled. This allows users to ignore or filter out transmissions as desired.

**Table 1. Function Table (Each Receiver)**

DIFFERENTIAL INPUT	ENABLES		OUTPUT
	G	$\bar{G}$	
A/B	G	$\bar{G}$	Y
$V_{ID} \geq V_{IT+}$	H	X	H
	X	L	H
$V_{IT} < V_{ID} < V_{IT+}$	H	X	?
	X	L	?
$V_{ID} \leq V_{IT-}$	H	X	L
	X	L	L
X	L	H	Z

## 9 Application and Implementation

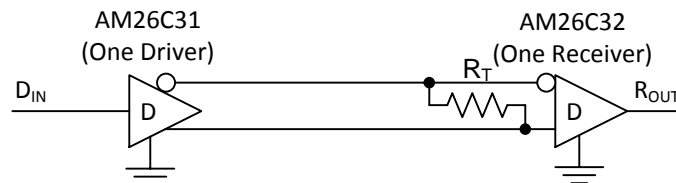
### NOTE

Information in the following applications sections is not part of the TI component specification, and TI does not warrant its accuracy or completeness. TI's customers are responsible for determining suitability of components for their purposes. Customers should validate and test their design implementation to confirm system functionality.

### 9.1 Application Information

When designing a system that uses drivers, receivers, and transceivers that comply with RS-422 or RS-485, proper cable termination is essential for highly reliable applications with reduced reflections in the transmission line. Because RS-422 allows only one driver on the bus, if termination is used, it is placed only at the end of the cable near the last receiver. In general, RS-485 requires termination at both ends of the cable. Factors to consider when determining the type of termination usually are performance requirements of the application and the ever-present factor, cost. The different types of termination techniques discussed are unterminated lines, parallel termination, AC termination, and multipoint termination. Laboratory waveforms for each termination technique (except multipoint termination) illustrate the usefulness and robustness of RS-422 (and, indirectly, RS-485). Similar results can be obtained if 485-compliant devices and termination techniques are used. For laboratory experiments, 100 feet of 100- $\Omega$ , 24-AWG, twisted-pair cable (Bertek) was used. A single driver and receiver, TI AM26C31C and AM26C32C, respectively, were tested at room temperature with a 5-V supply voltage. Two plots per termination technique are shown. In each plot, the top waveform is the driver input and the bottom waveform is the receiver output. To show voltage waveforms related to transmission-line reflections, the first plot shows output waveforms from the driver at the start of the cable; the second plot shows input waveforms to the receiver at the far end of the cable.

### 9.2 Typical Application



**Figure 4. Differential Terminated Configuration**

#### 9.2.1 Design Requirements

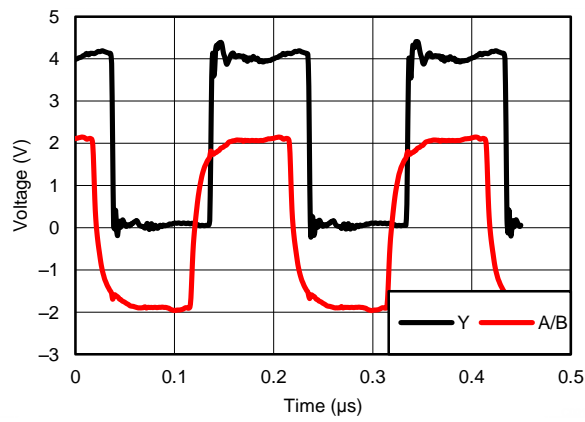
Resistor and capacitor (if used) termination values are shown for each laboratory experiment, but vary from system to system. For example, the termination resistor,  $R_T$ , must be within 20% of the characteristic impedance,  $Z_0$ , of the cable and can vary from about 80  $\Omega$  to 120  $\Omega$ .

#### 9.2.2 Detailed Design Procedure

Figure 4 shows a configuration with no termination. Although reflections are present at the receiver inputs at a data signaling rate of 200 kbps with no termination, the RS-422-compliant receiver reads only the input differential voltage and produces a clean signal at the output.

**Typical Application (continued)**

**9.2.3 Application Curve**



**Figure 5. Differential 120-Ω Terminated Output Waveforms (Cat 5E Cable)**

## 10 Power Supply Recommendations

Place 0.1- $\mu\text{F}$  bypass capacitors close to the power-supply pins to reduce errors coupling in from noisy or high impedance power supplies.

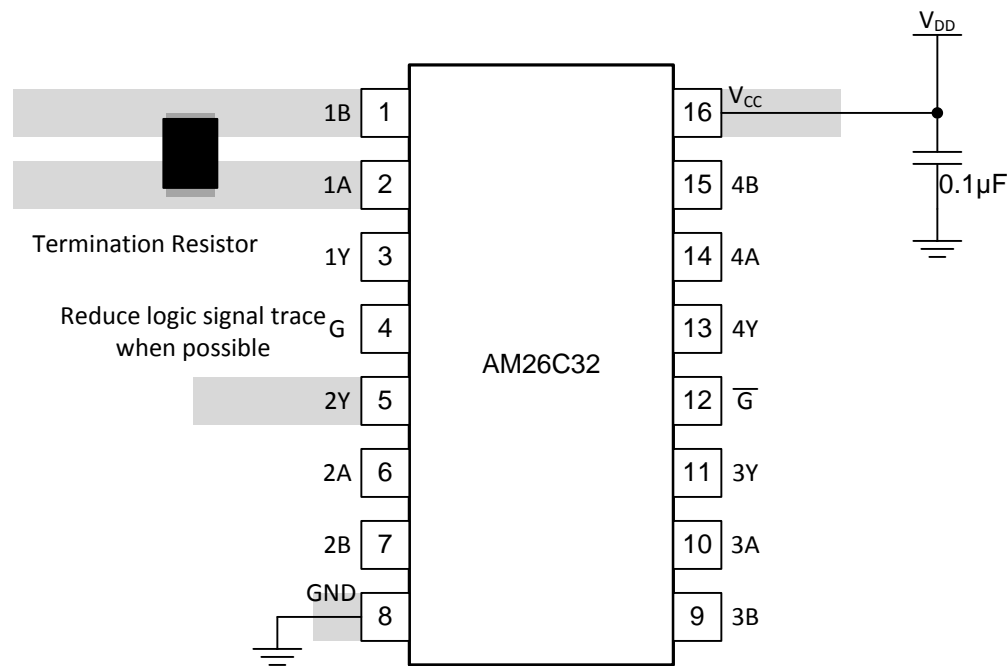
## 11 Layout

### 11.1 Layout Guidelines

For best operational performance of the device, use good PCB layout practices, including:

- Noise can propagate into analog circuitry through the power pins of the circuit as a whole, as well as the operational amplifier. Bypass capacitors are used to reduce the coupled noise by providing low impedance power sources local to the analog circuitry.
  - Connect low-ESR, 0.1- $\mu\text{F}$  ceramic bypass capacitors between each supply pin and ground, placed as close to the device as possible. A single bypass capacitor from V+ to ground is applicable for single supply applications.
- Separate grounding for analog and digital portions of circuitry is one of the simplest and most-effective methods of noise suppression. One or more layers on multilayer PCBs are usually devoted to ground planes. A ground plane helps distribute heat and reduces EMI noise pickup. Make sure to physically separate digital and analog grounds, paying attention to the flow of the ground current.
- To reduce parasitic coupling, run the input traces as far away from the supply or output traces as possible. If it is not possible to keep them separate, it is much better to cross the sensitive trace perpendicular as opposed to in parallel with the noisy trace.
- Place the external components as close to the device as possible. Keeping RF and RG close to the inverting input minimizes parasitic capacitance.
- Keep the length of input traces as short as possible. Always remember that the input traces are the most sensitive part of the circuit.
- Consider a driven, low-impedance guard ring around the critical traces. A guard ring can significantly reduce leakage currents from nearby traces that are at different potentials.

### 11.2 Layout Example



**Figure 6. Trace Layout on PCB and Recommendations**

## 12 Device and Documentation Support

### 12.1 Receiving Notification of Documentation Updates

To receive notification of documentation updates, navigate to the device product folder on ti.com. In the upper right corner, click on *Alert me* to register and receive a weekly digest of any product information that has changed. For change details, review the revision history included in any revised document.

### 12.2 Community Resources

The following links connect to TI community resources. Linked contents are provided "AS IS" by the respective contributors. They do not constitute TI specifications and do not necessarily reflect TI's views; see TI's [Terms of Use](#).

**TI E2E™ Online Community** *TI's Engineer-to-Engineer (E2E) Community*. Created to foster collaboration among engineers. At e2e.ti.com, you can ask questions, share knowledge, explore ideas and help solve problems with fellow engineers.

**Design Support** *TI's Design Support* Quickly find helpful E2E forums along with design support tools and contact information for technical support.

### 12.3 Trademarks

E2E is a trademark of Texas Instruments.  
All other trademarks are the property of their respective owners.

### 12.4 Electrostatic Discharge Caution



These devices have limited built-in ESD protection. The leads should be shorted together or the device placed in conductive foam during storage or handling to prevent electrostatic damage to the MOS gates.

### 12.5 Glossary

[SLYZ022](#) — *TI Glossary*.

This glossary lists and explains terms, acronyms, and definitions.

## 13 Mechanical, Packaging, and Orderable Information

The following pages include mechanical, packaging, and orderable information. This information is the most current data available for the designated devices. This data is subject to change without notice and revision of this document. For browser-based versions of this data sheet, refer to the left-hand navigation.

**PACKAGING INFORMATION**

Orderable Device	Status (1)	Package Type	Package Drawing	Pins	Package Qty	Eco Plan (2)	Lead finish/ Ball material (6)	MSL Peak Temp (3)	Op Temp (°C)	Device Marking (4/5)	Samples
5962-9164001Q2A	ACTIVE	LCCC	FK	20	1	Non-RoHS & Green	SNPB	N / A for Pkg Type	-55 to 125	5962-9164001Q2A AM26C32 MFKB	<a href="#">Samples</a>
5962-9164001QEA	ACTIVE	CDIP	J	16	1	Non-RoHS & Green	SNPB	N / A for Pkg Type	-55 to 125	5962-9164001QE A AM26C32MJB	<a href="#">Samples</a>
5962-9164001QFA	ACTIVE	CFP	W	16	1	Non-RoHS & Green	SNPB	N / A for Pkg Type	-55 to 125	5962-9164001QF A AM26C32MWB	<a href="#">Samples</a>
AM26C32CD	LIFEBUY	SOIC	D	16	40	RoHS & Green	NIPDAU	Level-1-260C-UNLIM	0 to 70	AM26C32C	
AM26C32CDB	LIFEBUY	SSOP	DB	16	80	RoHS & Green	NIPDAU	Level-1-260C-UNLIM		26C32	
AM26C32CDBR	LIFEBUY	SSOP	DB	16	2000	RoHS & Green	NIPDAU	Level-1-260C-UNLIM		26C32	
AM26C32CDE4	LIFEBUY	SOIC	D	16	40	RoHS & Green	NIPDAU	Level-1-260C-UNLIM	0 to 70	AM26C32C	
AM26C32CDR	LIFEBUY	SOIC	D	16	2500	RoHS & Green	NIPDAU	Level-1-260C-UNLIM	0 to 70	AM26C32C	
AM26C32CDRE4	LIFEBUY	SOIC	D	16	2500	RoHS & Green	NIPDAU	Level-1-260C-UNLIM	0 to 70	AM26C32C	
AM26C32CN	LIFEBUY	PDIP	N	16	25	RoHS & Green	NIPDAU	N / A for Pkg Type	0 to 70	AM26C32CN	
AM26C32CNE4	LIFEBUY	PDIP	N	16	25	RoHS & Green	NIPDAU	N / A for Pkg Type	0 to 70	AM26C32CN	
AM26C32CNSR	LIFEBUY	SO	NS	16	2000	RoHS & Green	NIPDAU	Level-1-260C-UNLIM	0 to 70	26C32	
AM26C32ID	LIFEBUY	SOIC	D	16	40	RoHS & Green	NIPDAU	Level-1-260C-UNLIM	-40 to 85	AM26C32I	
AM26C32IDE4	LIFEBUY	SOIC	D	16	40	RoHS & Green	NIPDAU	Level-1-260C-UNLIM	-40 to 85	AM26C32I	
AM26C32IDG4	LIFEBUY	SOIC	D	16	40	RoHS & Green	NIPDAU	Level-1-260C-UNLIM	-40 to 85	AM26C32I	
AM26C32IDR	ACTIVE	SOIC	D	16	2500	RoHS & Green	NIPDAU	Level-1-260C-UNLIM	-40 to 85	AM26C32I	<a href="#">Samples</a>
AM26C32IDRE4	ACTIVE	SOIC	D	16	2500	RoHS & Green	NIPDAU	Level-1-260C-UNLIM	-40 to 85	AM26C32I	<a href="#">Samples</a>
AM26C32IDRG4	ACTIVE	SOIC	D	16	2500	RoHS & Green	NIPDAU	Level-1-260C-UNLIM	-40 to 85	AM26C32I	<a href="#">Samples</a>
AM26C32IN	LIFEBUY	PDIP	N	16	25	RoHS & Green	NIPDAU	N / A for Pkg Type	-40 to 85	AM26C32IN	
AM26C32INSR	ACTIVE	SO	NS	16	2000	RoHS & Green	NIPDAU	Level-1-260C-UNLIM	-40 to 85	26C32I	<a href="#">Samples</a>
AM26C32IPW	LIFEBUY	TSSOP	PW	16	90	RoHS & Green	NIPDAU	Level-1-260C-UNLIM	-40 to 85	26C32I	
AM26C32IPWG4	LIFEBUY	TSSOP	PW	16	90	RoHS & Green	NIPDAU	Level-1-260C-UNLIM	-40 to 85	26C32I	

Orderable Device	Status (1)	Package Type	Package Drawing	Pins	Package Qty	Eco Plan (2)	Lead finish/ Ball material (6)	MSL Peak Temp (3)	Op Temp (°C)	Device Marking (4/5)	Samples
AM26C32IPWR	ACTIVE	TSSOP	PW	16	2000	RoHS & Green	NIPDAU	Level-1-260C-UNLIM	-40 to 85	26C32I	<a href="#">Samples</a>
AM26C32IPWRG4	ACTIVE	TSSOP	PW	16	2000	RoHS & Green	NIPDAU	Level-1-260C-UNLIM	-40 to 85	26C32I	<a href="#">Samples</a>
AM26C32MFKB	ACTIVE	LCCC	FK	20	1	Non-RoHS & Green	SNPB	N / A for Pkg Type	-55 to 125	5962-9164001Q2A AM26C32 MFKB	<a href="#">Samples</a>
AM26C32MJB	ACTIVE	CDIP	J	16	1	Non-RoHS & Green	SNPB	N / A for Pkg Type	-55 to 125	5962-9164001QE A AM26C32MJB	<a href="#">Samples</a>
AM26C32MWB	ACTIVE	CFP	W	16	1	Non-RoHS & Green	SNPB	N / A for Pkg Type	-55 to 125	5962-9164001QF A AM26C32MWB	<a href="#">Samples</a>
AM26C32QD	LIFEBUY	SOIC	D	16	40	RoHS & Green	NIPDAU	Level-1-260C-UNLIM	-40 to 125	AM26C32Q	
AM26C32QDG4	LIFEBUY	SOIC	D	16	40	RoHS & Green	NIPDAU	Level-1-260C-UNLIM	-40 to 125	26C32Q	
AM26C32QDR	ACTIVE	SOIC	D	16	2500	RoHS & Green	NIPDAU	Level-1-260C-UNLIM	-40 to 125	AM26C32Q	<a href="#">Samples</a>

(1) The marketing status values are defined as follows:

**ACTIVE:** Product device recommended for new designs.

**LIFEBUY:** TI has announced that the device will be discontinued, and a lifetime-buy period is in effect.

**NRND:** Not recommended for new designs. Device is in production to support existing customers, but TI does not recommend using this part in a new design.

**PREVIEW:** Device has been announced but is not in production. Samples may or may not be available.

**OBSOLETE:** TI has discontinued the production of the device.

(2) **RoHS:** TI defines "RoHS" to mean semiconductor products that are compliant with the current EU RoHS requirements for all 10 RoHS substances, including the requirement that RoHS substance do not exceed 0.1% by weight in homogeneous materials. Where designed to be soldered at high temperatures, "RoHS" products are suitable for use in specified lead-free processes. TI may reference these types of products as "Pb-Free".

**RoHS Exempt:** TI defines "RoHS Exempt" to mean products that contain lead but are compliant with EU RoHS pursuant to a specific EU RoHS exemption.

**Green:** TI defines "Green" to mean the content of Chlorine (Cl) and Bromine (Br) based flame retardants meet JS709B low halogen requirements of <=1000ppm threshold. Antimony trioxide based flame retardants must also meet the <=1000ppm threshold requirement.

(3) MSL, Peak Temp. - The Moisture Sensitivity Level rating according to the JEDEC industry standard classifications, and peak solder temperature.

(4) There may be additional marking, which relates to the logo, the lot trace code information, or the environmental category on the device.

(5) Multiple Device Markings will be inside parentheses. Only one Device Marking contained in parentheses and separated by a "~" will appear on a device. If a line is indented then it is a continuation of the previous line and the two combined represent the entire Device Marking for that device.

(6) Lead finish/Ball material - Orderable Devices may have multiple material finish options. Finish options are separated by a vertical ruled line. Lead finish/Ball material values may wrap to two lines if the finish value exceeds the maximum column width.

**Important Information and Disclaimer:**The information provided on this page represents TI's knowledge and belief as of the date that it is provided. TI bases its knowledge and belief on information provided by third parties, and makes no representation or warranty as to the accuracy of such information. Efforts are underway to better integrate information from third parties. TI has taken and continues to take reasonable steps to provide representative and accurate information but may not have conducted destructive testing or chemical analysis on incoming materials and chemicals. TI and TI suppliers consider certain information to be proprietary, and thus CAS numbers and other limited information may not be available for release.

In no event shall TI's liability arising out of such information exceed the total purchase price of the TI part(s) at issue in this document sold by TI to Customer on an annual basis.

**OTHER QUALIFIED VERSIONS OF AM26C32, AM26C32M :**

- Catalog : [AM26C32](#)
  
- Enhanced Product : [AM26C32-EP](#), [AM26C32-EP](#)
  
- Military : [AM26C32M](#)

NOTE: Qualified Version Definitions:

- Catalog - TI's standard catalog product
  
- Enhanced Product - Supports Defense, Aerospace and Medical Applications
  
- Military - QML certified for Military and Defense Applications



**TAPE AND REEL INFORMATION**

**QUADRANT ASSIGNMENTS FOR PIN 1 ORIENTATION IN TAPE**

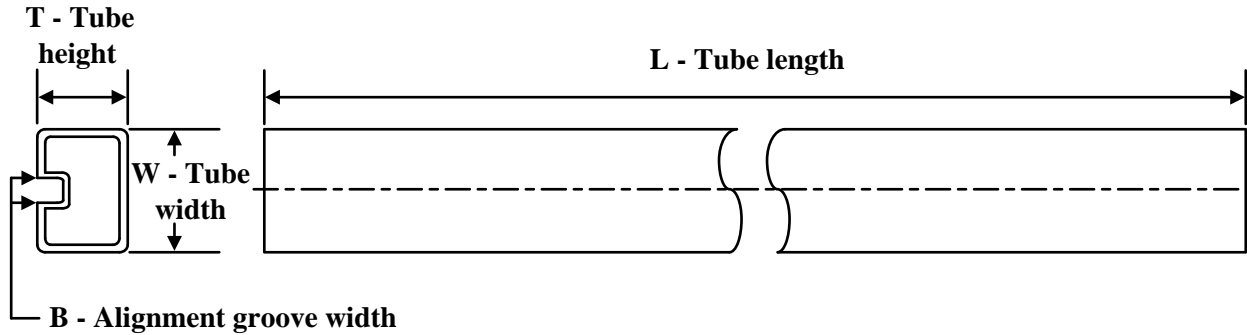

\*All dimensions are nominal

Device	Package Type	Package Drawing	Pins	SPQ	Reel Diameter (mm)	Reel Width W1 (mm)	A0 (mm)	B0 (mm)	K0 (mm)	P1 (mm)	W (mm)	Pin1 Quadrant
AM26C32CDBR	SSOP	DB	16	2000	330.0	16.4	8.35	6.6	2.4	12.0	16.0	Q1
AM26C32CDR	SOIC	D	16	2500	330.0	16.4	6.5	10.3	2.1	8.0	16.0	Q1
AM26C32CNSR	SO	NS	16	2000	330.0	16.4	8.2	10.5	2.5	12.0	16.0	Q1
AM26C32IDR	SOIC	D	16	2500	330.0	16.4	6.5	10.3	2.1	8.0	16.0	Q1
AM26C32INSR	SO	NS	16	2000	330.0	16.4	8.2	10.5	2.5	12.0	16.0	Q1
AM26C32IPWR	TSSOP	PW	16	2000	330.0	12.4	6.9	5.6	1.6	8.0	12.0	Q1
AM26C32QDR	SOIC	D	16	2500	330.0	16.4	6.5	10.3	2.1	8.0	16.0	Q1

**TAPE AND REEL BOX DIMENSIONS**


\*All dimensions are nominal

Device	Package Type	Package Drawing	Pins	SPQ	Length (mm)	Width (mm)	Height (mm)
AM26C32CDBR	SSOP	DB	16	2000	356.0	356.0	35.0
AM26C32CDR	SOIC	D	16	2500	340.5	336.1	32.0
AM26C32CNSR	SO	NS	16	2000	356.0	356.0	35.0
AM26C32IDR	SOIC	D	16	2500	340.5	336.1	32.0
AM26C32INSR	SO	NS	16	2000	367.0	367.0	38.0
AM26C32IPWR	TSSOP	PW	16	2000	367.0	367.0	35.0
AM26C32QDR	SOIC	D	16	2500	350.0	350.0	43.0

**TUBE**


\*All dimensions are nominal

Device	Package Name	Package Type	Pins	SPQ	L (mm)	W (mm)	T (μm)	B (mm)
5962-9164001Q2A	FK	LCCC	20	1	506.98	12.06	2030	NA
5962-9164001QFA	W	CFP	16	1	506.98	26.16	6220	NA
AM26C32CD	D	SOIC	16	40	507	8	3940	4.32
AM26C32CDE4	D	SOIC	16	40	507	8	3940	4.32
AM26C32CN	N	PDIP	16	25	506	13.97	11230	4.32
AM26C32CN	N	PDIP	16	25	506	13.97	11230	4.32
AM26C32CNE4	N	PDIP	16	25	506	13.97	11230	4.32
AM26C32CNE4	N	PDIP	16	25	506	13.97	11230	4.32
AM26C32ID	D	SOIC	16	40	507	8	3940	4.32
AM26C32IDE4	D	SOIC	16	40	507	8	3940	4.32
AM26C32IDG4	D	SOIC	16	40	507	8	3940	4.32
AM26C32IN	N	PDIP	16	25	506	13.97	11230	4.32
AM26C32IPW	PW	TSSOP	16	90	530	10.2	3600	3.5
AM26C32IPWG4	PW	TSSOP	16	90	530	10.2	3600	3.5
AM26C32MFKB	FK	LCCC	20	1	506.98	12.06	2030	NA
AM26C32MWB	W	CFP	16	1	506.98	26.16	6220	NA
AM26C32QD	D	SOIC	16	40	505.46	6.76	3810	4
AM26C32QDG4	D	SOIC	16	40	505.46	6.76	3810	4

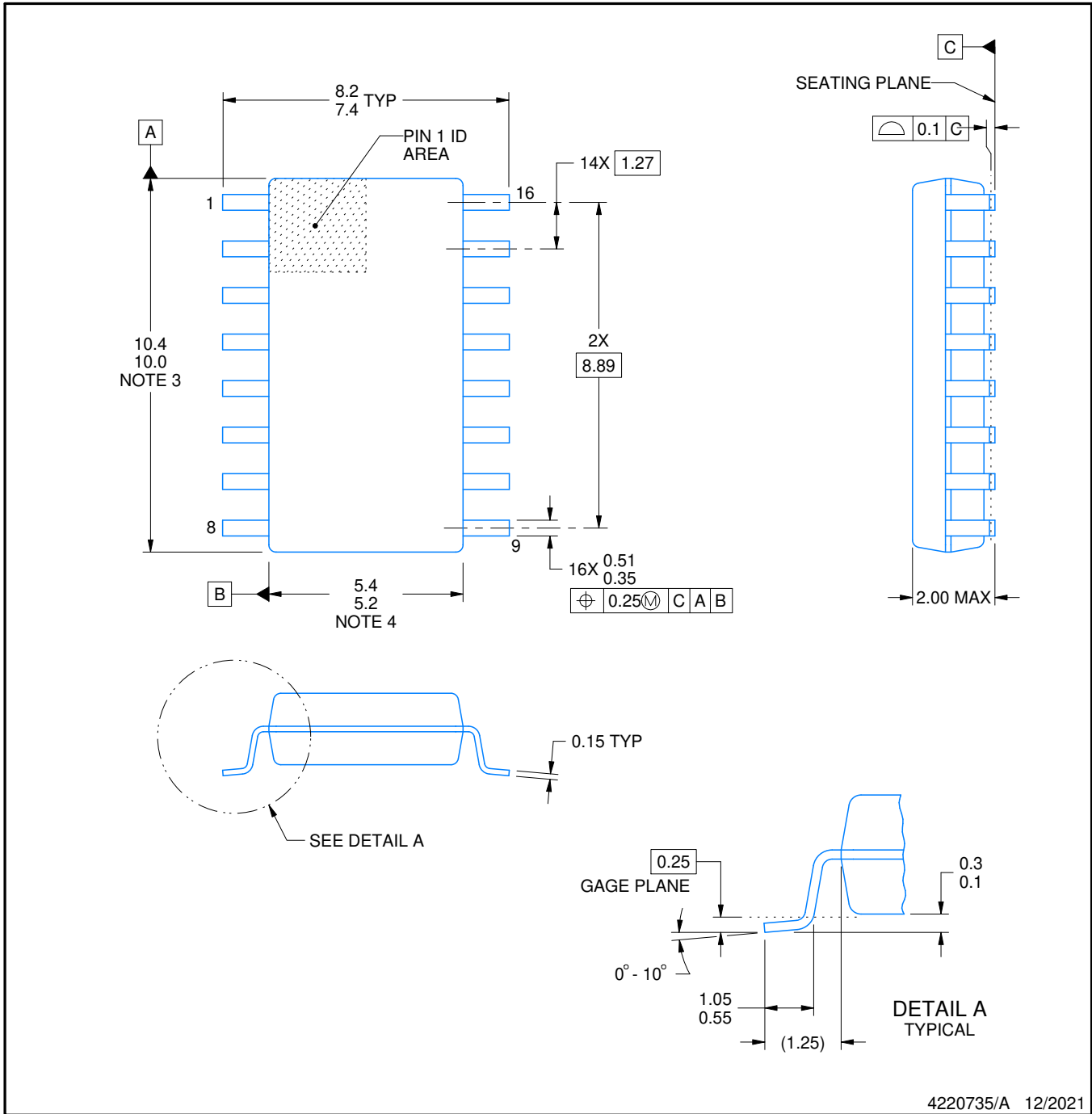


# PACKAGE OUTLINE

## NS0016A

### SOP - 2.00 mm max height

SOP



4220735/A 12/2021

#### NOTES:

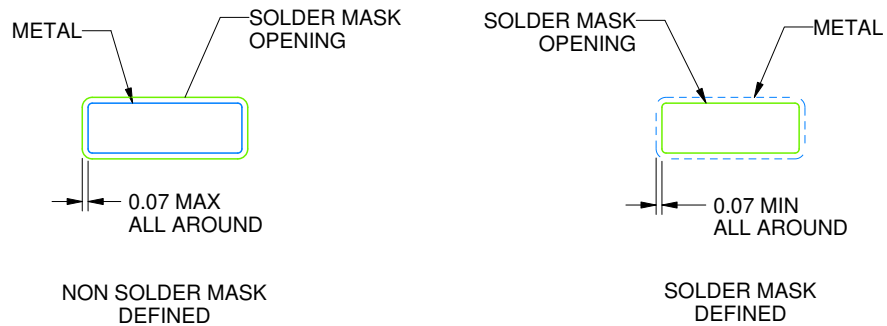
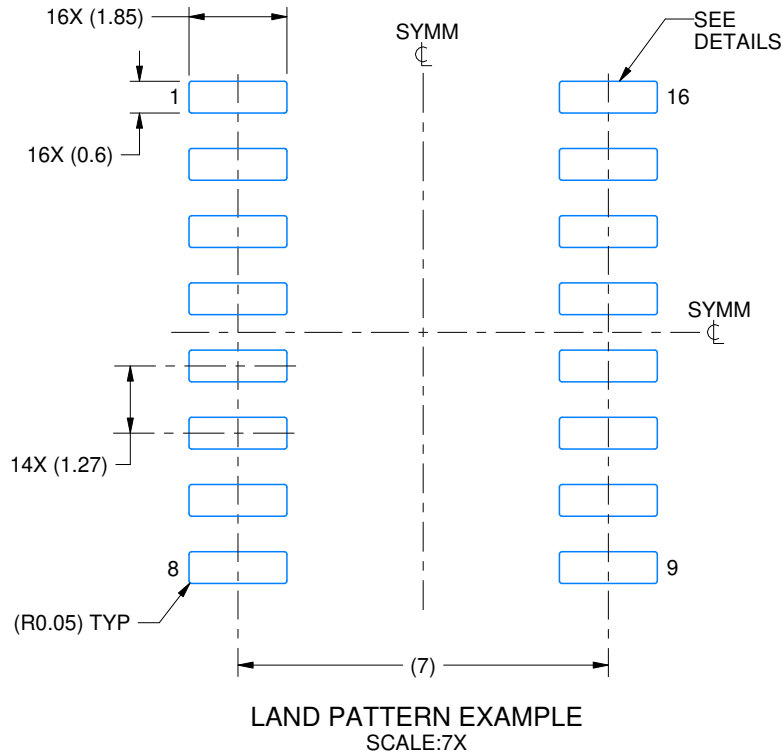
1. All linear dimensions are in millimeters. Dimensions in parenthesis are for reference only. Dimensioning and tolerancing per ASME Y14.5M.
2. This drawing is subject to change without notice.
3. This dimension does not include mold flash, protrusions, or gate burrs. Mold flash, protrusions, or gate burrs shall not exceed 0.15 mm, per side.
4. This dimension does not include interlead flash. Interlead flash shall not exceed 0.25 mm, per side.

# EXAMPLE BOARD LAYOUT

NS0016A

SOP - 2.00 mm max height

SOP



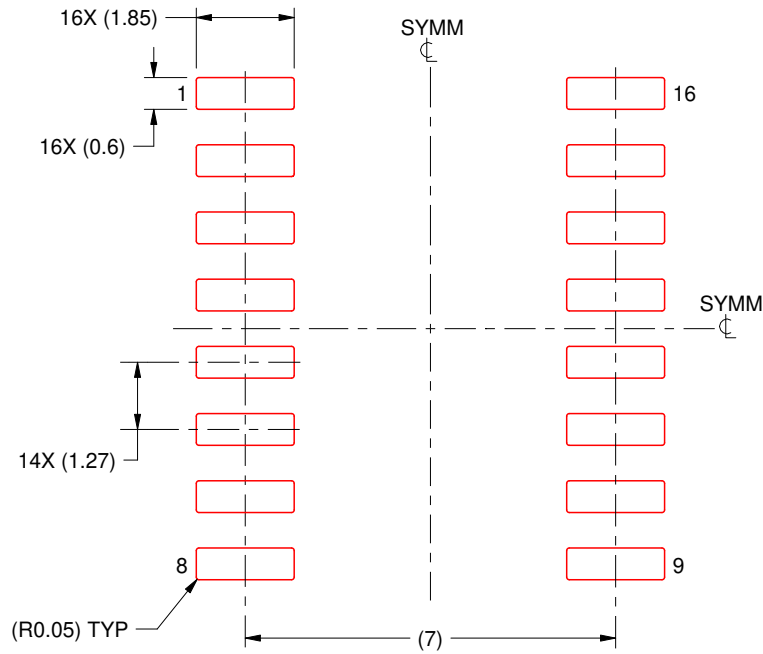
SOLDER MASK DETAILS

4220735/A 12/2021

NOTES: (continued)

5. Publication IPC-7351 may have alternate designs.

6. Solder mask tolerances between and around signal pads can vary based on board fabrication site.



SOLDER PASTE EXAMPLE  
 BASED ON 0.125 mm THICK STENCIL  
 SCALE:7X

4220735/A 12/2021

NOTES: (continued)



- 7. Laser cutting apertures with trapezoidal walls and rounded corners may offer better paste release. IPC-7525 may have alternate design recommendations.
- 8. Board assembly site may have different recommendations for stencil design.

D (R-PDSO-G16)

PLASTIC SMALL OUTLINE

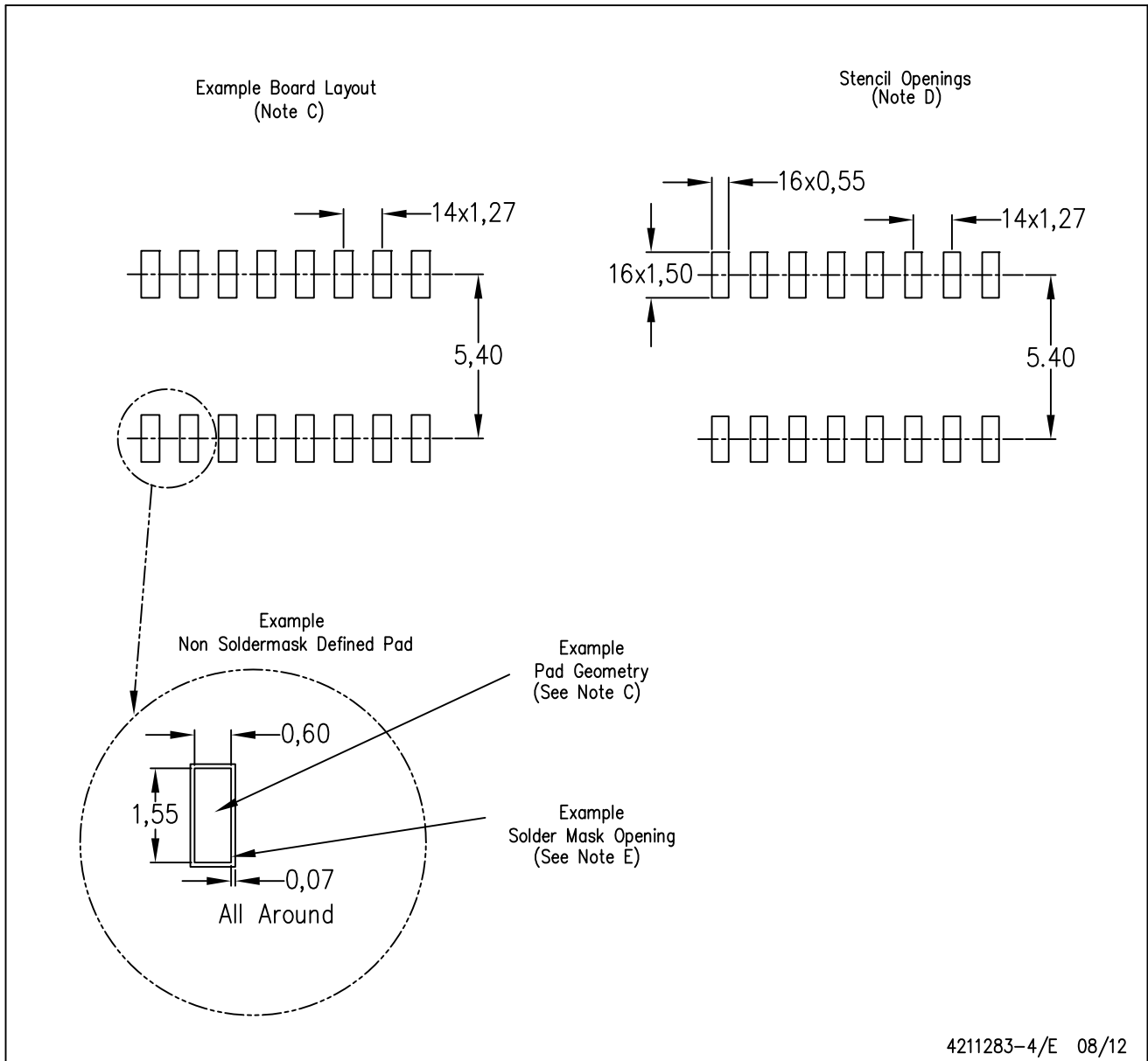


4040047-6/M 06/11

- NOTES:
- A. All linear dimensions are in inches (millimeters).
  - B. This drawing is subject to change without notice.
  -  C. Body length does not include mold flash, protrusions, or gate burrs. Mold flash, protrusions, or gate burrs shall not exceed 0.006 (0,15) each side.
  -  D. Body width does not include interlead flash. Interlead flash shall not exceed 0.017 (0,43) each side.
  - E. Reference JEDEC MS-012 variation AC.

D (R-PDSO-G16)

PLASTIC SMALL OUTLINE



- NOTES:
- All linear dimensions are in millimeters.
  - This drawing is subject to change without notice.
  - Publication IPC-7351 is recommended for alternate designs.
  - Laser cutting apertures with trapezoidal walls and also rounding corners will offer better paste release. Customers should contact their board assembly site for stencil design recommendations. Refer to IPC-7525 for other stencil recommendations.
  - Customers should contact their board fabrication site for solder mask tolerances between and around signal pads.



# PW0016A



# PACKAGE OUTLINE

## TSSOP - 1.2 mm max height

SMALL OUTLINE PACKAGE



4220204/A 02/2017

### NOTES:

1. All linear dimensions are in millimeters. Any dimensions in parenthesis are for reference only. Dimensioning and tolerancing per ASME Y14.5M.
2. This drawing is subject to change without notice.
3. This dimension does not include mold flash, protrusions, or gate burrs. Mold flash, protrusions, or gate burrs shall not exceed 0.15 mm per side.
4. This dimension does not include interlead flash. Interlead flash shall not exceed 0.25 mm per side.
5. Reference JEDEC registration MO-153.

# EXAMPLE BOARD LAYOUT

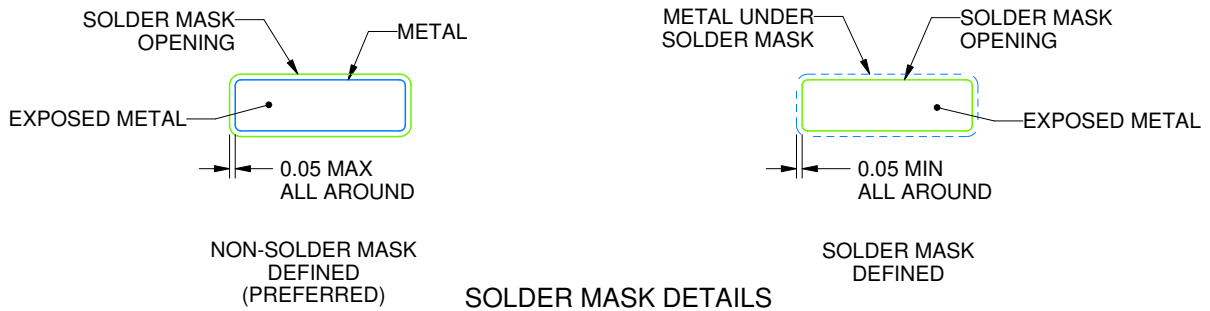
PW0016A

TSSOP - 1.2 mm max height

SMALL OUTLINE PACKAGE



LAND PATTERN EXAMPLE  
EXPOSED METAL SHOWN  
SCALE: 10X



SOLDER MASK DETAILS

4220204/A 02/2017

NOTES: (continued)

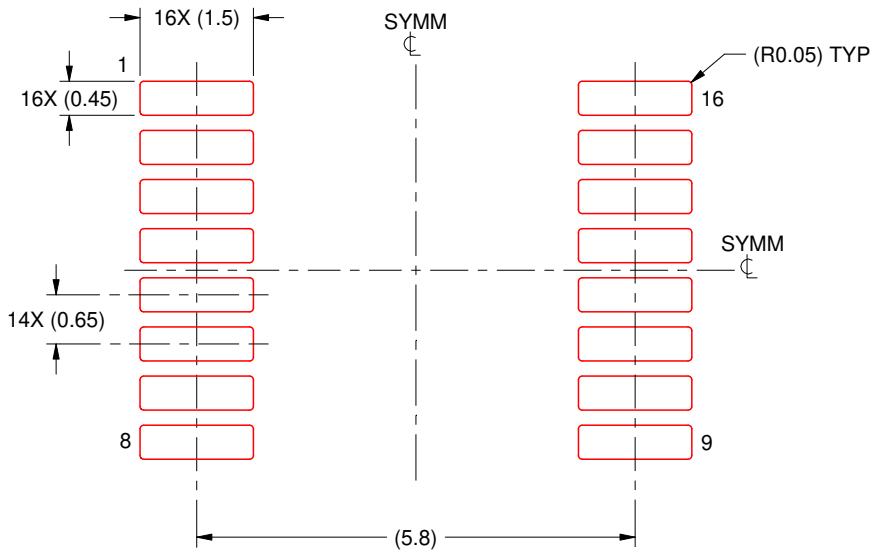
- 6. Publication IPC-7351 may have alternate designs.
- 7. Solder mask tolerances between and around signal pads can vary based on board fabrication site.

# EXAMPLE STENCIL DESIGN

PW0016A

TSSOP - 1.2 mm max height

SMALL OUTLINE PACKAGE



SOLDER PASTE EXAMPLE  
BASED ON 0.125 mm THICK STENCIL  
SCALE: 10X

4220204/A 02/2017

NOTES: (continued)

8. Laser cutting apertures with trapezoidal walls and rounded corners may offer better paste release. IPC-7525 may have alternate design recommendations.
9. Board assembly site may have different recommendations for stencil design.

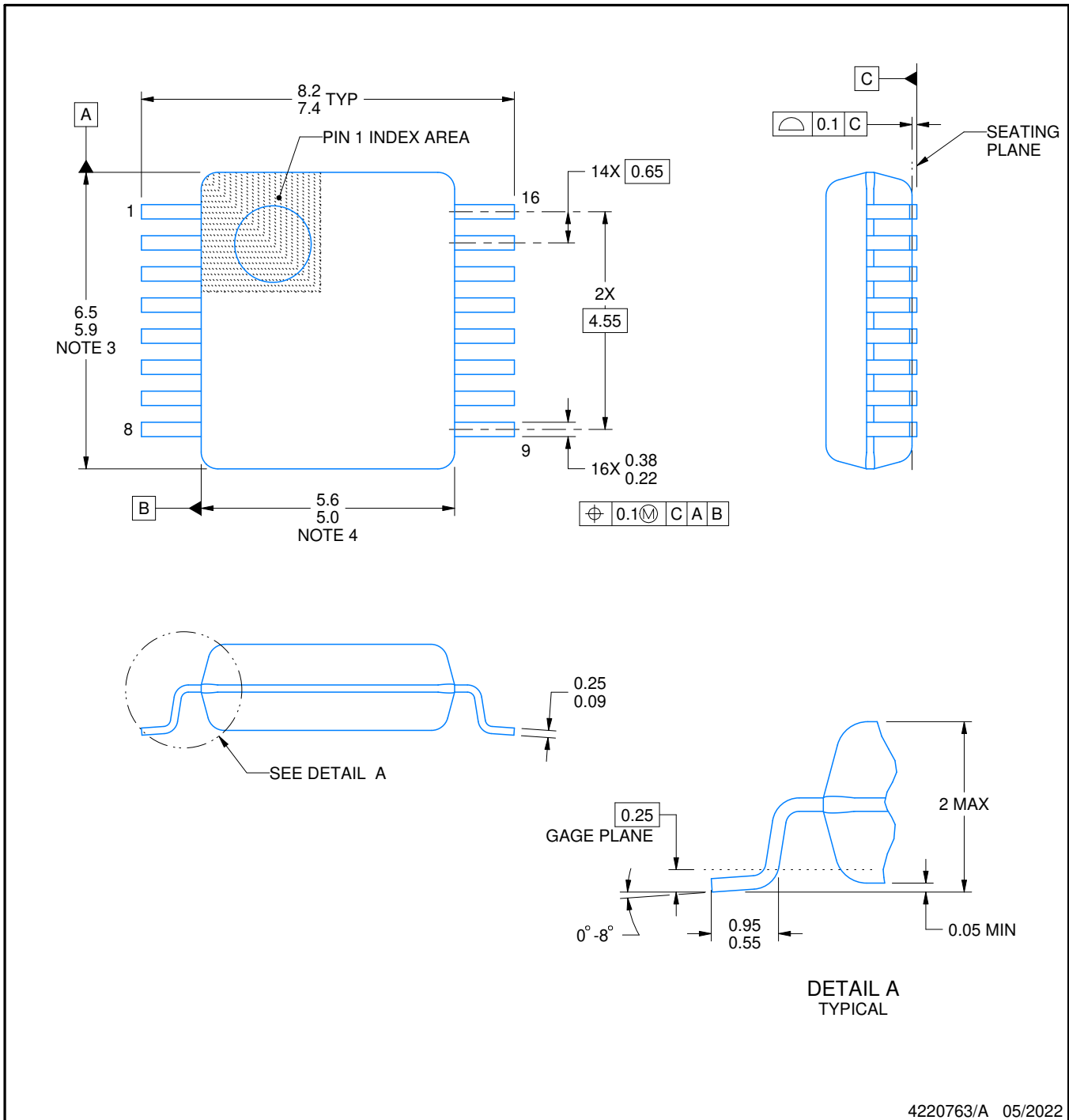
# DB0016A



# PACKAGE OUTLINE

## SSOP - 2 mm max height

SMALL OUTLINE PACKAGE



4220763/A 05/2022

NOTES:

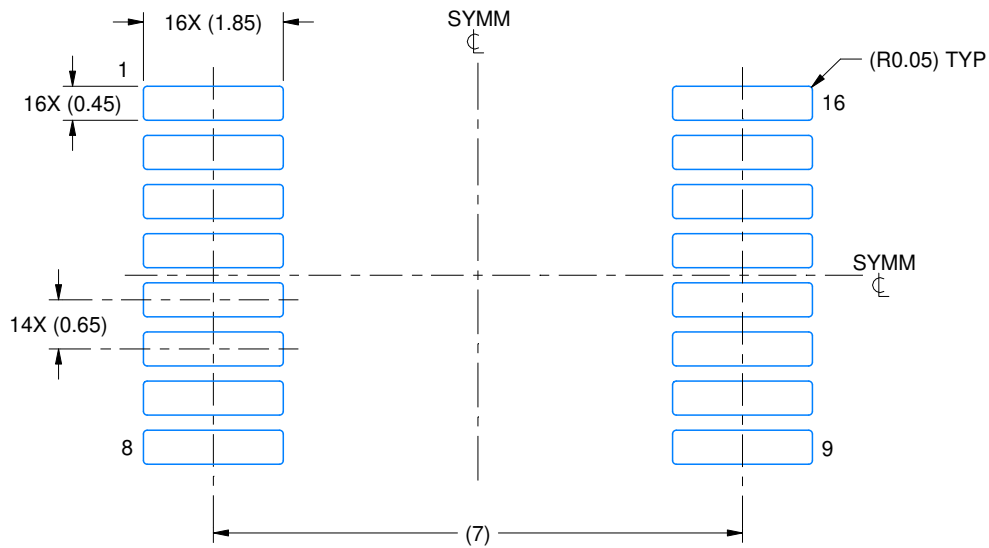
- All linear dimensions are in millimeters. Any dimensions in parenthesis are for reference only. Dimensioning and tolerancing per ASME Y14.5M.
- This drawing is subject to change without notice.
- This dimension does not include mold flash, protrusions, or gate burrs. Mold flash, protrusions, or gate burrs shall not exceed 0.15 mm per side.
- Reference JEDEC registration MO-150.

# EXAMPLE BOARD LAYOUT

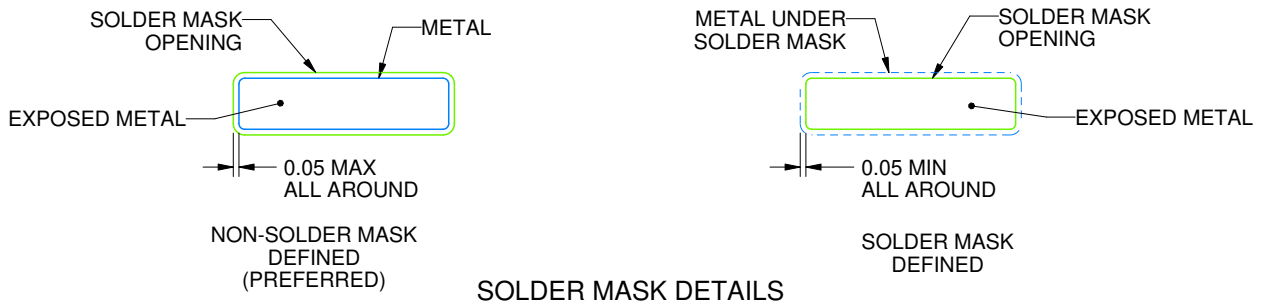
DB0016A

SSOP - 2 mm max height

SMALL OUTLINE PACKAGE



LAND PATTERN EXAMPLE  
EXPOSED METAL SHOWN  
SCALE: 10X



4220763/A 05/2022

NOTES: (continued)

5. Publication IPC-7351 may have alternate designs.
6. Solder mask tolerances between and around signal pads can vary based on board fabrication site.



# MECHANICAL DATA

NS (R-PDSO-G\*\*)

PLASTIC SMALL-OUTLINE PACKAGE

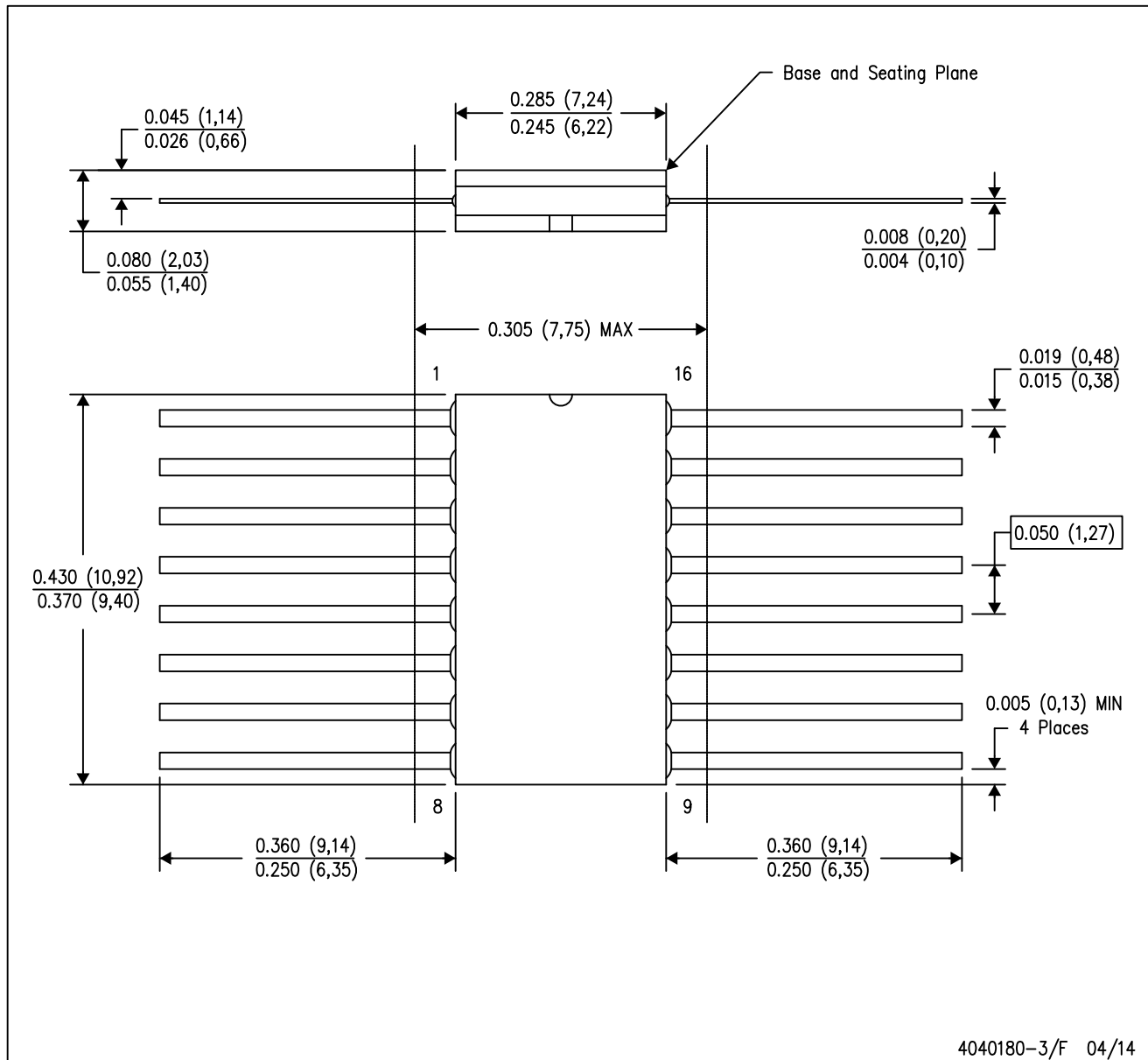
14-PINS SHOWN



- NOTES:
- A. All linear dimensions are in millimeters.
  - B. This drawing is subject to change without notice.
  - C. Body dimensions do not include mold flash or protrusion, not to exceed 0,15.

W (R-GDFP-F16)

CERAMIC DUAL FLATPACK



- NOTES:
- A. All linear dimensions are in inches (millimeters).
  - B. This drawing is subject to change without notice.
  - C. This package can be hermetically sealed with a ceramic lid using glass frit.
  - D. Index point is provided on cap for terminal identification only.
  - E. Falls within MIL STD 1835 GDFP2-F16



## GENERIC PACKAGE VIEW

**FK 20**

**LCCC - 2.03 mm max height**

8.89 x 8.89, 1.27 mm pitch

LEADLESS CERAMIC CHIP CARRIER

This image is a representation of the package family, actual package may vary.  
Refer to the product data sheet for package details.



4229370VA\

J (R-GDIP-T\*\*)

14 LEADS SHOWN

CERAMIC DUAL IN-LINE PACKAGE



DIM \ PINS **	14	16	18	20
A	0.300 (7,62) BSC	0.300 (7,62) BSC	0.300 (7,62) BSC	0.300 (7,62) BSC
B MAX	0.785 (19,94)	.840 (21,34)	0.960 (24,38)	1.060 (26,92)
B MIN	—	—	—	—
C MAX	0.300 (7,62)	0.300 (7,62)	0.310 (7,87)	0.300 (7,62)
C MIN	0.245 (6,22)	0.245 (6,22)	0.220 (5,59)	0.245 (6,22)



4040083/F 03/03

- NOTES:
- All linear dimensions are in inches (millimeters).
  - This drawing is subject to change without notice.
  - This package is hermetically sealed with a ceramic lid using glass frit.
  - Index point is provided on cap for terminal identification only on press ceramic glass frit seal only.
  - Falls within MIL STD 1835 GDIP1-T14, GDIP1-T16, GDIP1-T18 and GDIP1-T20.

N (R-PDIP-T\*\*)

PLASTIC DUAL-IN-LINE PACKAGE

16 PINS SHOWN



- NOTES:
- A. All linear dimensions are in inches (millimeters).
  - B. This drawing is subject to change without notice.
  - C Falls within JEDEC MS-001, except 18 and 20 pin minimum body length (Dim A).
  - D The 20 pin end lead shoulder width is a vendor option, either half or full width.

4040049/E 12/2002

## IMPORTANT NOTICE AND DISCLAIMER

TI PROVIDES TECHNICAL AND RELIABILITY DATA (INCLUDING DATA SHEETS), DESIGN RESOURCES (INCLUDING REFERENCE DESIGNS), APPLICATION OR OTHER DESIGN ADVICE, WEB TOOLS, SAFETY INFORMATION, AND OTHER RESOURCES "AS IS" AND WITH ALL FAULTS, AND DISCLAIMS ALL WARRANTIES, EXPRESS AND IMPLIED, INCLUDING WITHOUT LIMITATION ANY IMPLIED WARRANTIES OF MERCHANTABILITY, FITNESS FOR A PARTICULAR PURPOSE OR NON-INFRINGEMENT OF THIRD PARTY INTELLECTUAL PROPERTY RIGHTS.

These resources are intended for skilled developers designing with TI products. You are solely responsible for (1) selecting the appropriate TI products for your application, (2) designing, validating and testing your application, and (3) ensuring your application meets applicable standards, and any other safety, security, regulatory or other requirements.

These resources are subject to change without notice. TI grants you permission to use these resources only for development of an application that uses the TI products described in the resource. Other reproduction and display of these resources is prohibited. No license is granted to any other TI intellectual property right or to any third party intellectual property right. TI disclaims responsibility for, and you will fully indemnify TI and its representatives against, any claims, damages, costs, losses, and liabilities arising out of your use of these resources.

TI's products are provided subject to [TI's Terms of Sale](#) or other applicable terms available either on [ti.com](https://www.ti.com) or provided in conjunction with such TI products. TI's provision of these resources does not expand or otherwise alter TI's applicable warranties or warranty disclaimers for TI products.

TI objects to and rejects any additional or different terms you may have proposed.

Mailing Address: Texas Instruments, Post Office Box 655303, Dallas, Texas 75265  
Copyright © 2023, Texas Instruments Incorporated