

10120126 - X 0 J - X X X L F

4-COLUMN DIFFERENTIAL SIGNAL

LEAD-FREE DESIGNATION ONLY WITH APPLICABLE PLATING CODES

LETTER	PLATING (SEE NOTE 6)	
	APPLICATION	TYPE (REFERENCE)
B	TELCORDIA CO	0.76um GOLD or GXT
C	TELCORDIA UE	1.27um GOLD
D	TELCORDIA CO	0.76um GOLD or GXT, LEAD-FREE
E	TELCORDIA UE	1.27um GOLD, LEAD-FREE

NUMBER	GUIDE PIN STYLE (SEE NOTE 8)
0	STANDARD GUIDE PIN, MACHINED
1	STANDARD GUIDE PIN, ROLLED

NUMBER	CONTACT MATING WIPE LENGTH		COMPLIANT TAIL TYPE (SEE NOTE 9)
	SIGNAL	GROUND	
1	2 MM	4 MM	0.55 (0.0217") DRILL
2	3 MM	4 MM	0.55 (0.0217") DRILL
3	2 MM	4 MM	0.45 MICRO (0.0177") DRILL
4	3 MM	4 MM	0.45 MICRO (0.0177") DRILL
5	2 MM	3 MM	0.55 (0.0217") DRILL
6	3 MM	3 MM	0.55 (0.0217") DRILL
7	2 MM	3 MM	0.45 MICRO (0.0177") DRILL
8	3 MM	3 MM	0.45 MICRO (0.0177") DRILL

FOR CUSTOM-LOADED MODULES, SEE INDIVIDUAL CUSTOM DRAWINGS WITH THE DRAWING-NUMBER FORMAT OF 10120126-XXXX, WHERE: "X" DENOTES MODULE TYPE PER CHART ON THIS SHEET "YYYY" IS A SEQUENTIAL NUMBER BEGINNING WITH "0001".

MODULE DESCRIPTION	LETTER DESIGNATION REPRESENTED IN DASH NUMBER										BASE MODULE
LEFT POLARIZING GUIDANCE MODULE (SEE SHEET 6)	N	J	A	B	C	D	E	F	G	H	
	NO KEY NO GUIDE PIN										
RIGHT POLARIZING GUIDANCE MODULE (SEE SHEET 7)	Z	Y	P	Q	R	S	T	U	V	W	
	NO KEY NO GUIDE PIN										
OPEN MODULE (TWO WALL) (SEE SHEET 2)	0 (ZERO)										
LEFT WALL MODULE (SEE SHEET 3)	L										
RIGHT WALL MODULE (SEE SHEET 4)	M										
FOUR WALL MODULE (SEE SHEET 5)	1 (ONE)										

	UNGROUND	GROUND
FHS	Ø2.35-Ø2.55	Ø2.35-Ø2.55
PAD	N/A	Ø5.50
PLATED	NO	YES
DRILL(mm)	2.44mm	2.58mm
DRILL(in)	0.096"	0.1015"

SCREW P/N	DESCRIPTION	BOARD THICKNESS
10091790-002LF	#2-56 X 0.375" LG. PHILIPS PANHEAD W/SQ CONICAL WASHER	1.60-5.00mm
10091790-003LF	#2-56 X 0.375" LG. PHILIPS PANHEAD W/SQ CONICAL WASHER	5.00-10.00mm

spec ref	TOLERANCES UNLESS OTHERWISE SPECIFIED		
tolerance std	TOLERANCES UNLESS OTHERWISE SPECIFIED		
ISO 406	0.X	±0.3	
ISO 1101	0.XX	±0.10	
surface	linear	0.XXX	±0.05
	angular	0°	±2°

dr	Yong-Keat Lim	2012/03/05	projection	mm	size	A2	scale	1:1
eng	Sandar Soe	2016/03/07		mm	ecn no	ELX-S-17624-1		
chr	-	-	product family	-	rel level	Released		
appr	Chen-Hong Tan	2016/03/17						
Amphenol FCI		MODULE ASSEMBLY, XCEDE HD			cat. no.	10120126	rev	C
www.fci.com		Vertical Header, 4 Pair 4 Column			Product - Customer Drw		sheet 1 of 8	

Amphenol FCI

© 2016 AFCI

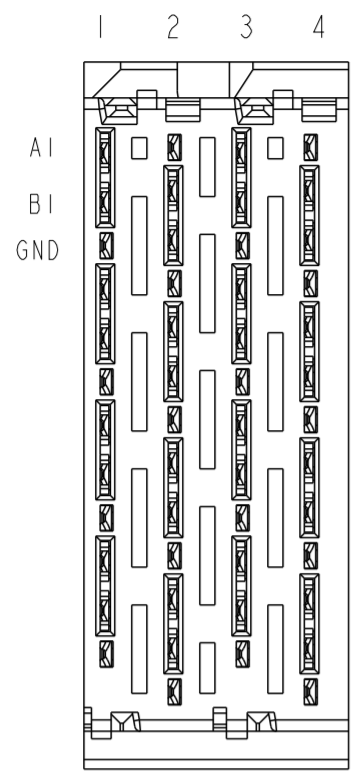

SEE NOTE 5

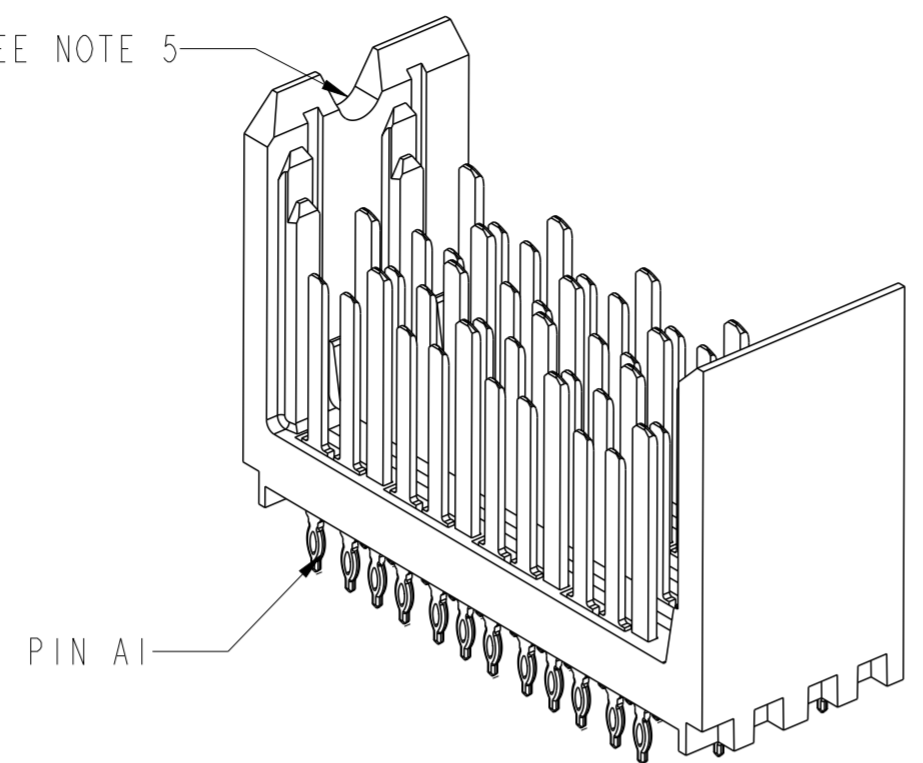

OPEN WALL MODULE

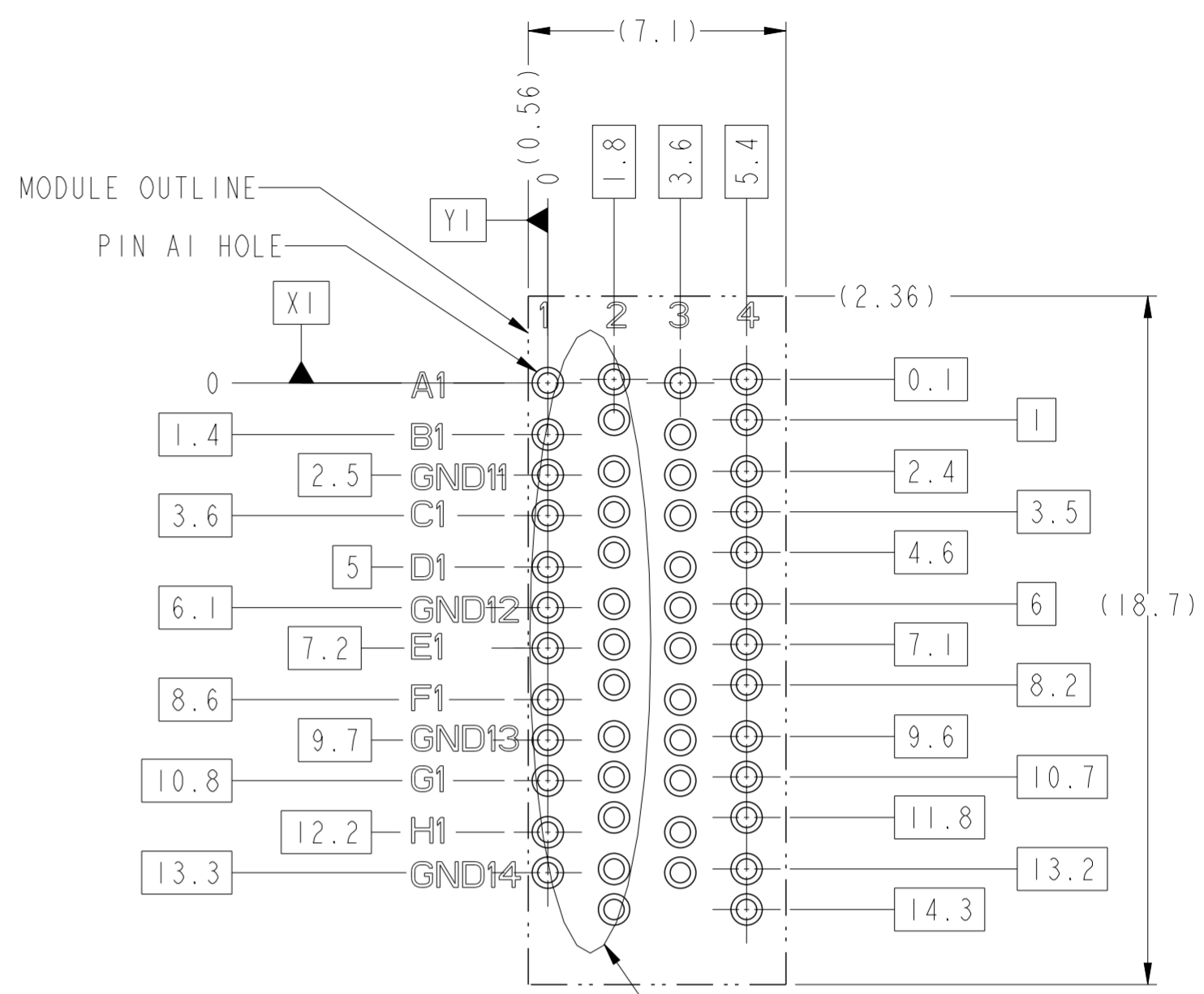

SEE DETAIL A ON SHEET 8 FOR DETAILS

BP HOLE PATTERN COMPONENT SIDE

OPEN WALL MODULE BACKPLANE FOOTPRINT

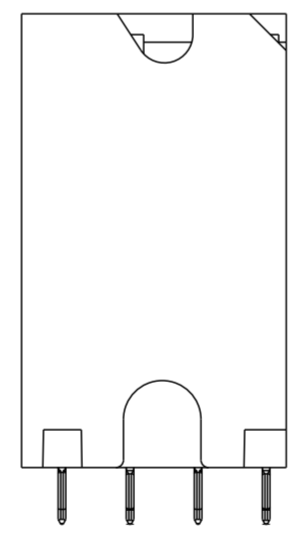
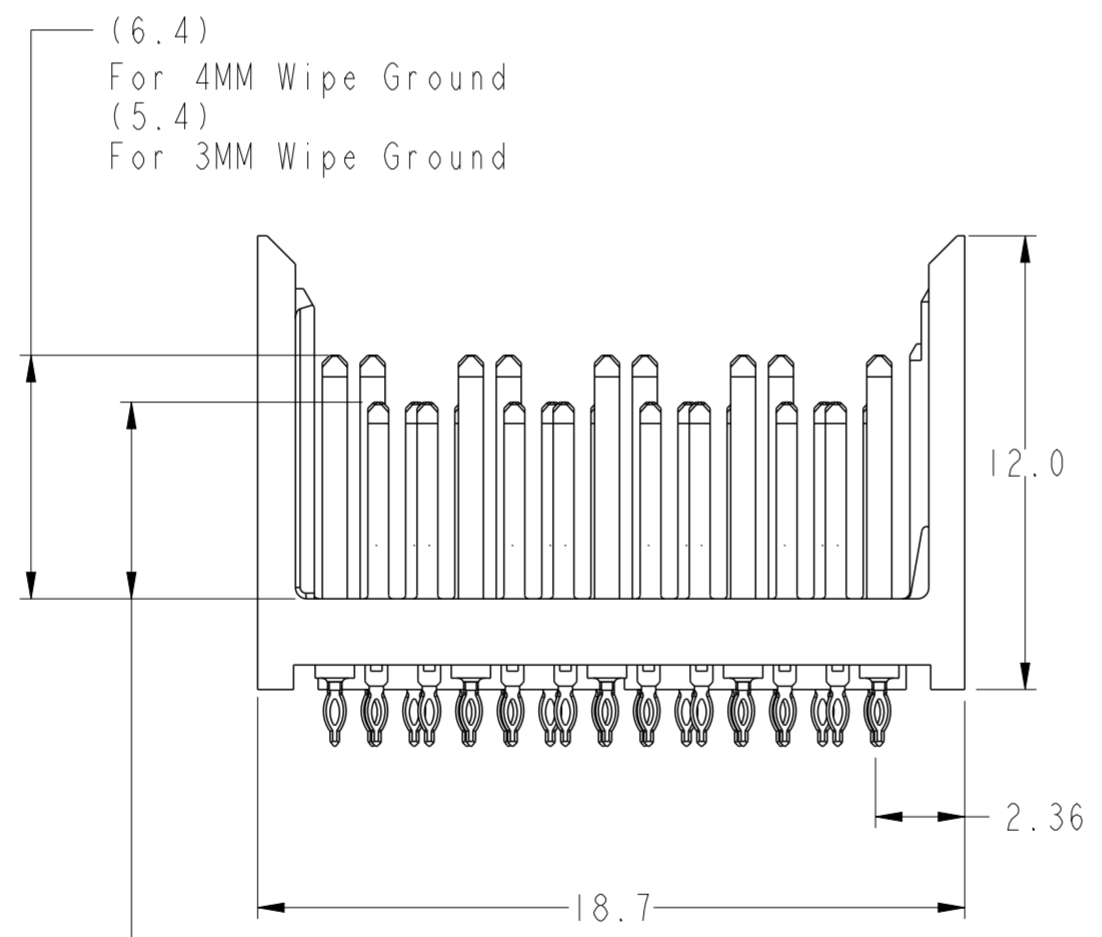
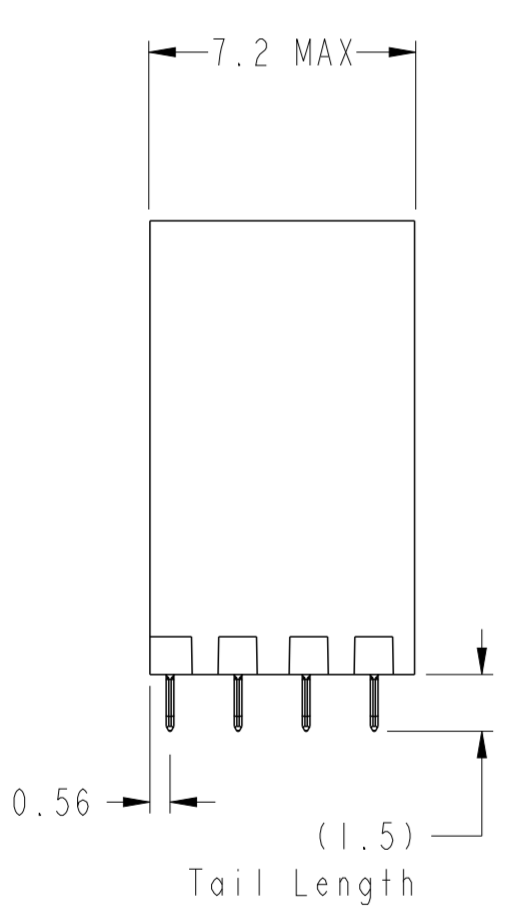

Amphenol FCI

© 2016 AFCI

spec ref	-	dr	Yong-Keat Lim	2012/03/05	projection	mm	size	A2	scale	1:1
tolerance std	ISO 406 ISO 1101	eng	Sandar Soe	2016/03/07		mm	ecn no	ELX-S-17624-1	rel level	Released
TOLERANCES UNLESS OTHERWISE SPECIFIED		chr	-	appr						
surface	ISO 1302	linear	0.X	±0.3			MODULE ASSEMBLY, XCEDE HD Vertical Header, 4 Pair 4 Column		drwg no 10120126	rev C
		angular	0°	±2°	www.fci.com	cat. no.	-	Product - Customer Drw	sheet 2 of 8	

PDS: Rev :C

STATUS:Released

Printed: Mar 17, 2016

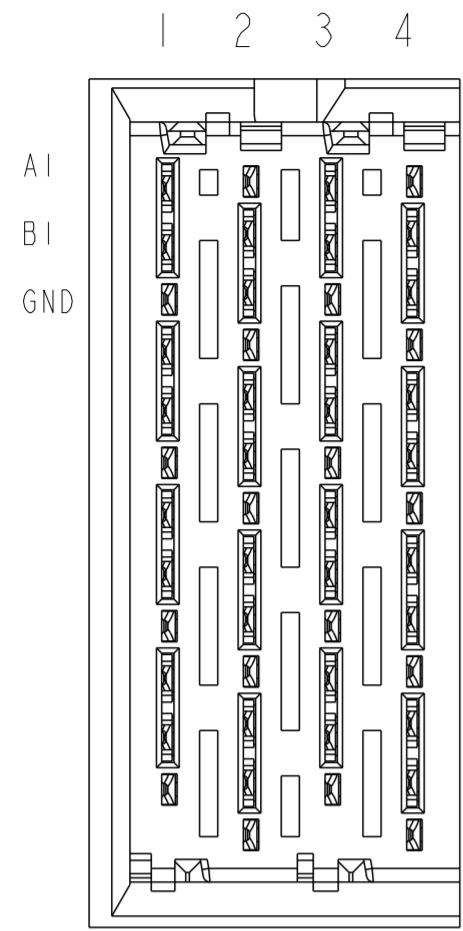

LEFT WALL MODULE

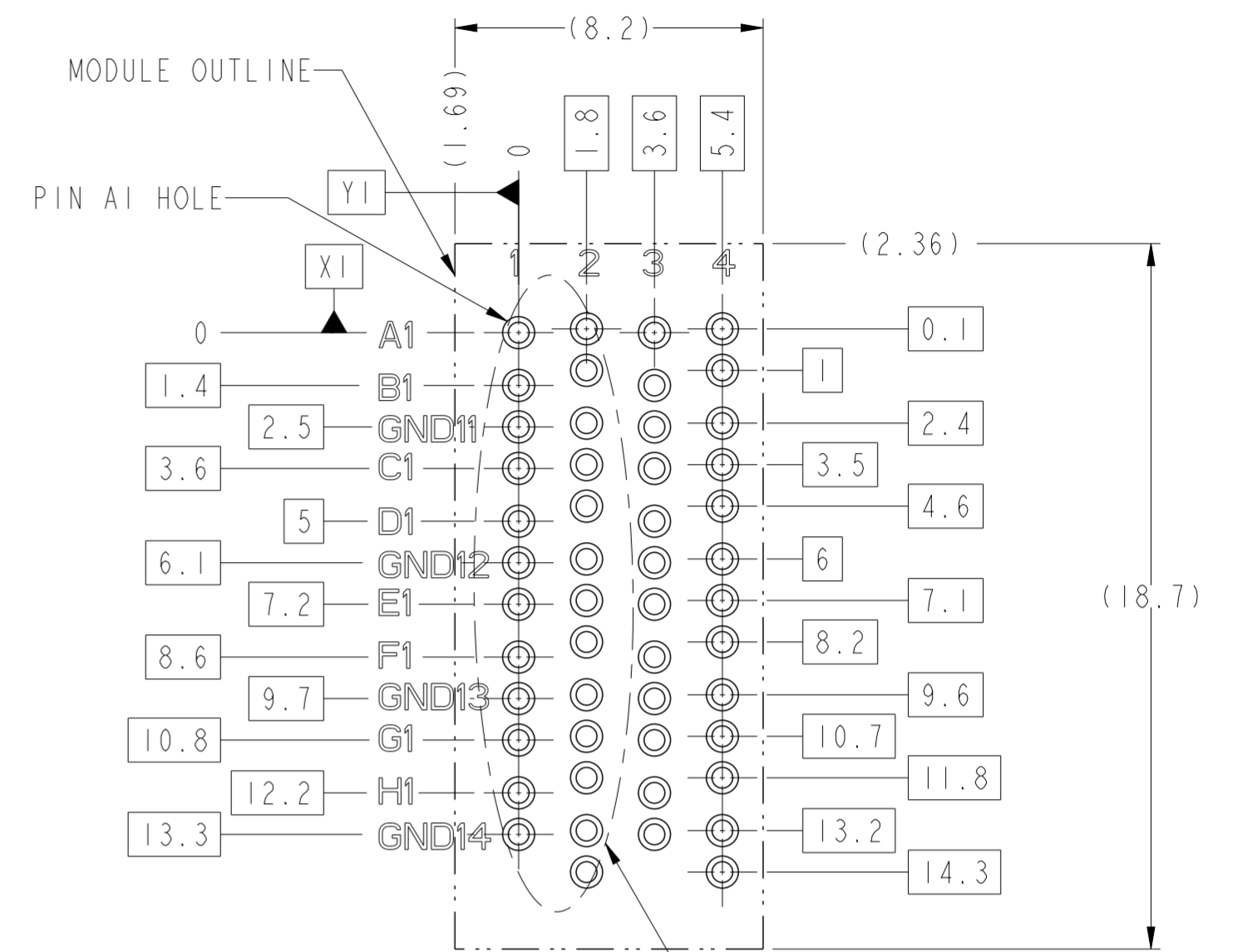
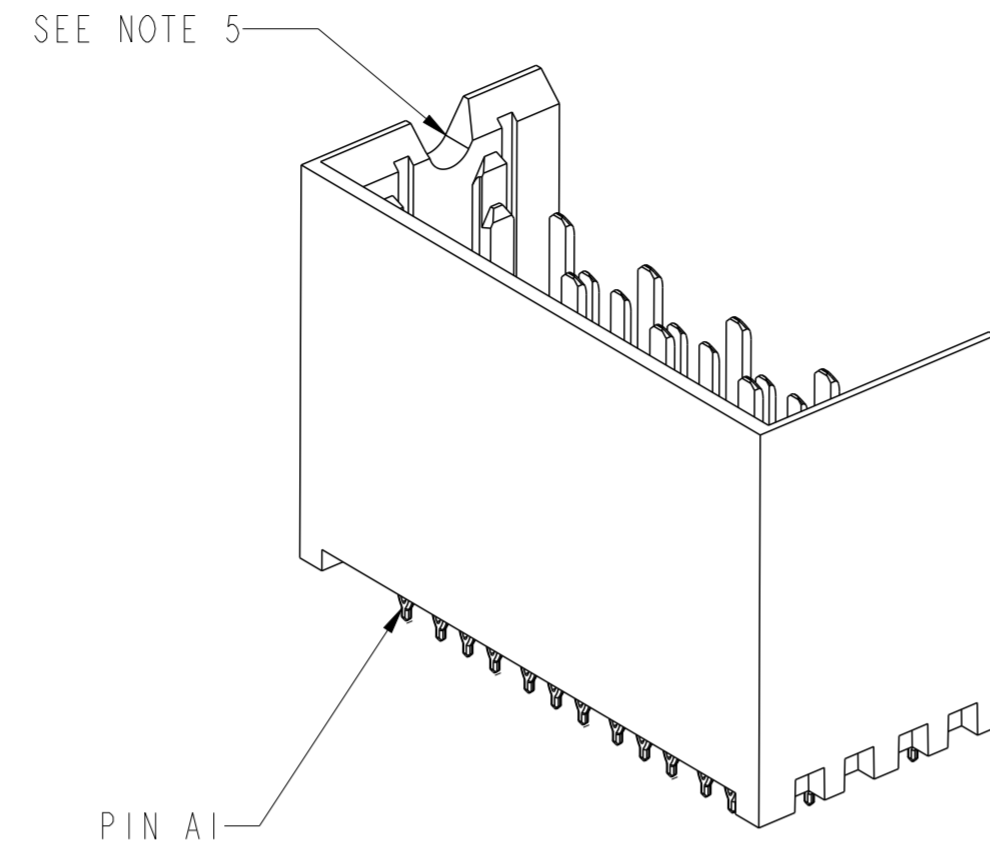

BP HOLE PATTERN COMPONENT SIDE
LEFT WALL MODULE BACKPLANE FOOTPRINT

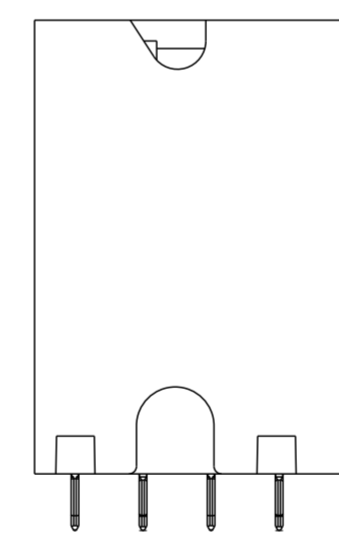
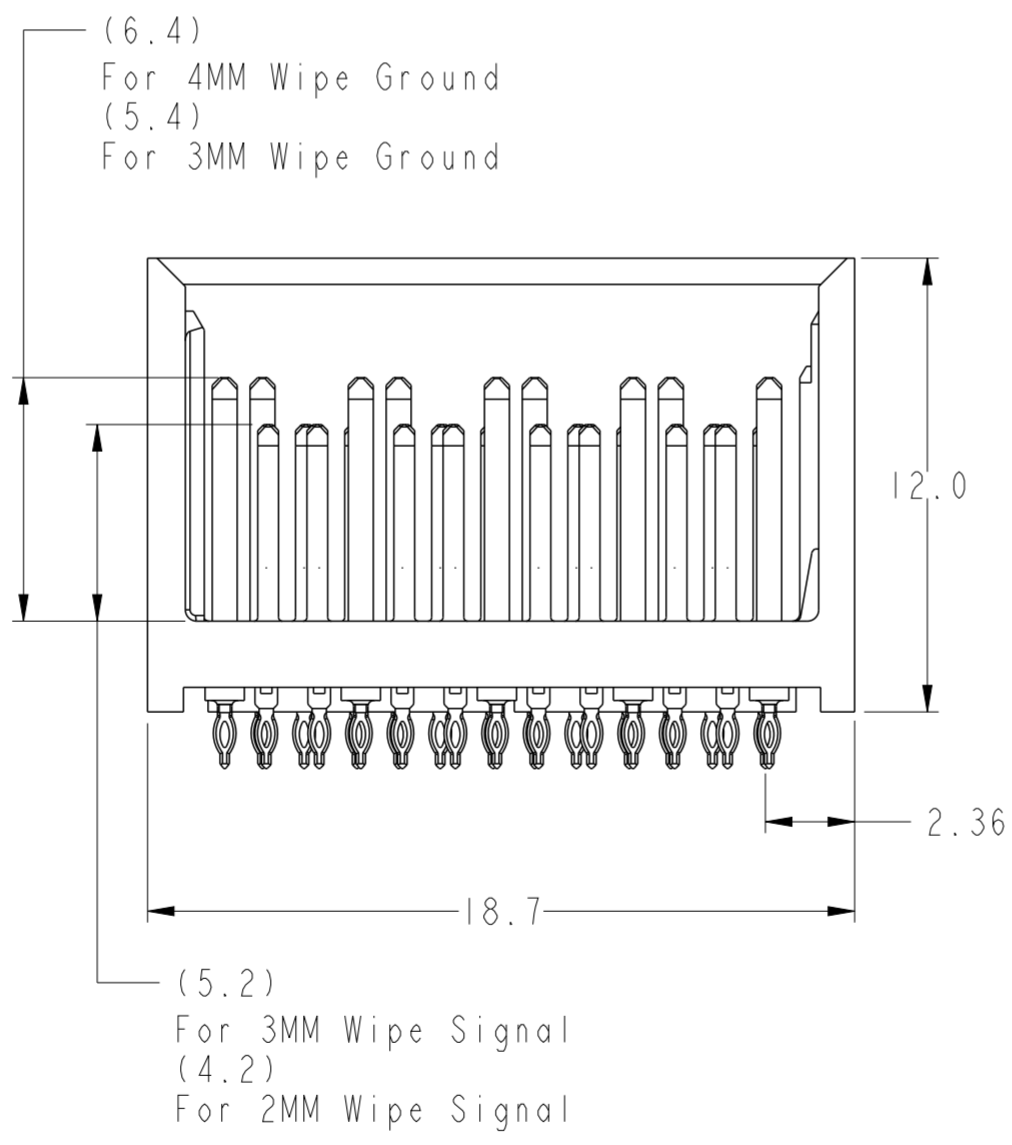
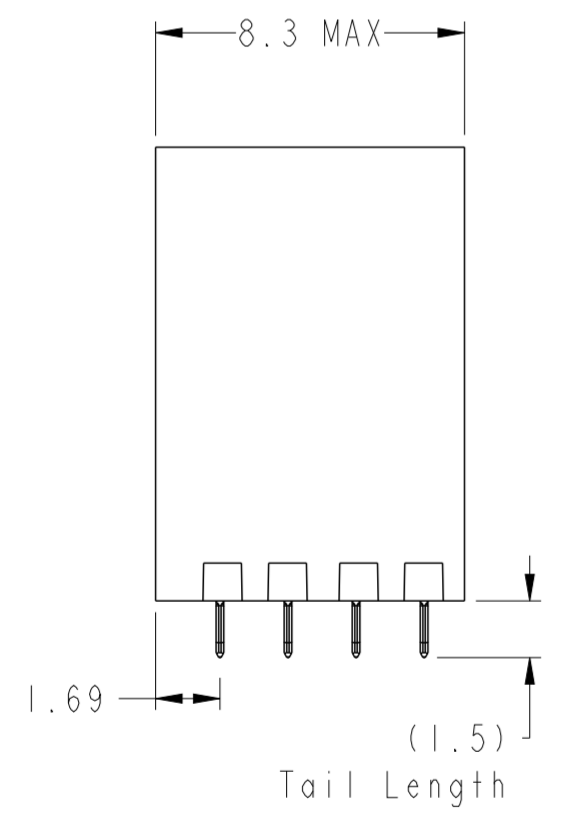

Amphenol
FCi

© 2016 AFci

spec ref	-	dr	Yong-Keat Lim	2012/03/05	projection	mm	size	A2	scale	1:1
tolerance std	ISO 406 ISO 1101	eng	Sandar Soe	2016/03/07		mm	ecn no	ELX-S-17624-1	rel level	Released
TOLERANCES UNLESS OTHERWISE SPECIFIED		chr	-	appr						
surface	ISO 1302	linear	0.X	±0.3			MODULE ASSEMBLY, XCEDE HD Vertical Header, 4 Pair 4 Column		dwg no 10120126	rev C
		angular	0°	±2°	www.fci.com	cat. no.	-	Product - Customer Drw	sheet 3 of 8	

PDS: Rev :C

STATUS:Released

Printed: Mar 17, 2016

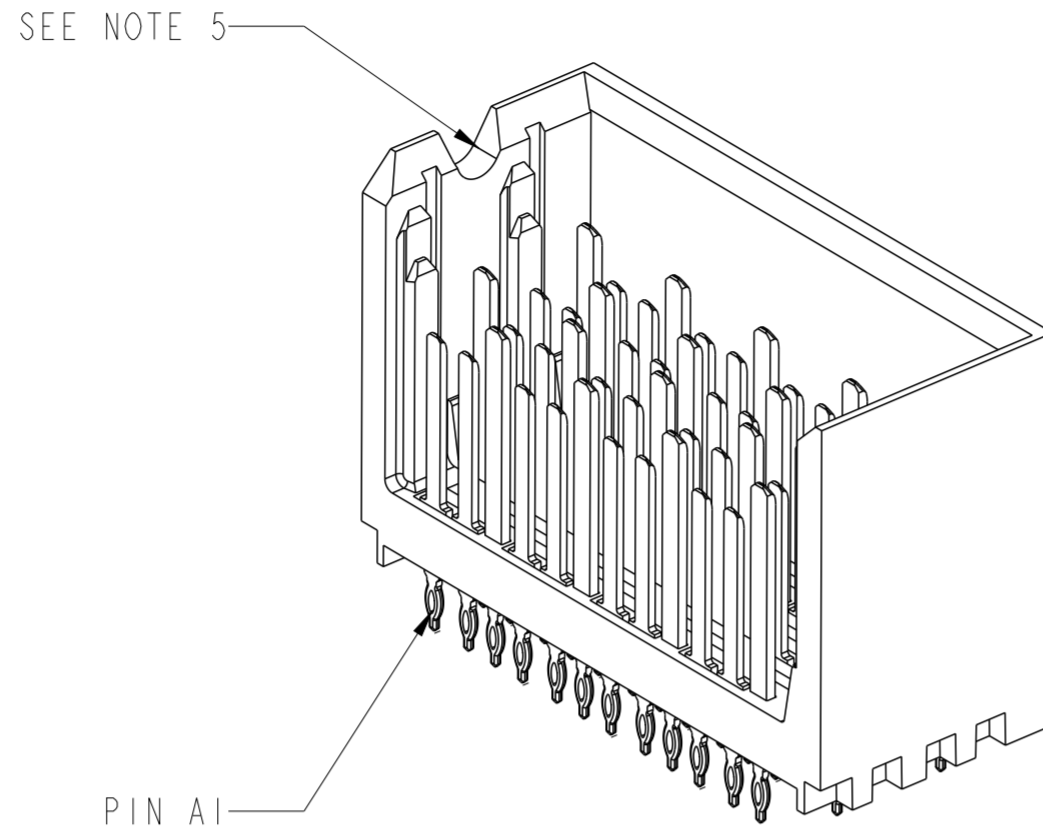
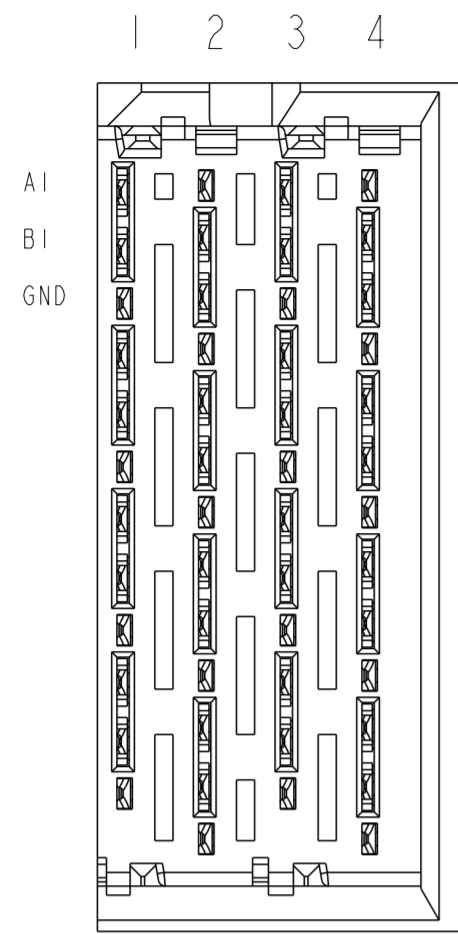

RIGHT WALL MODULE

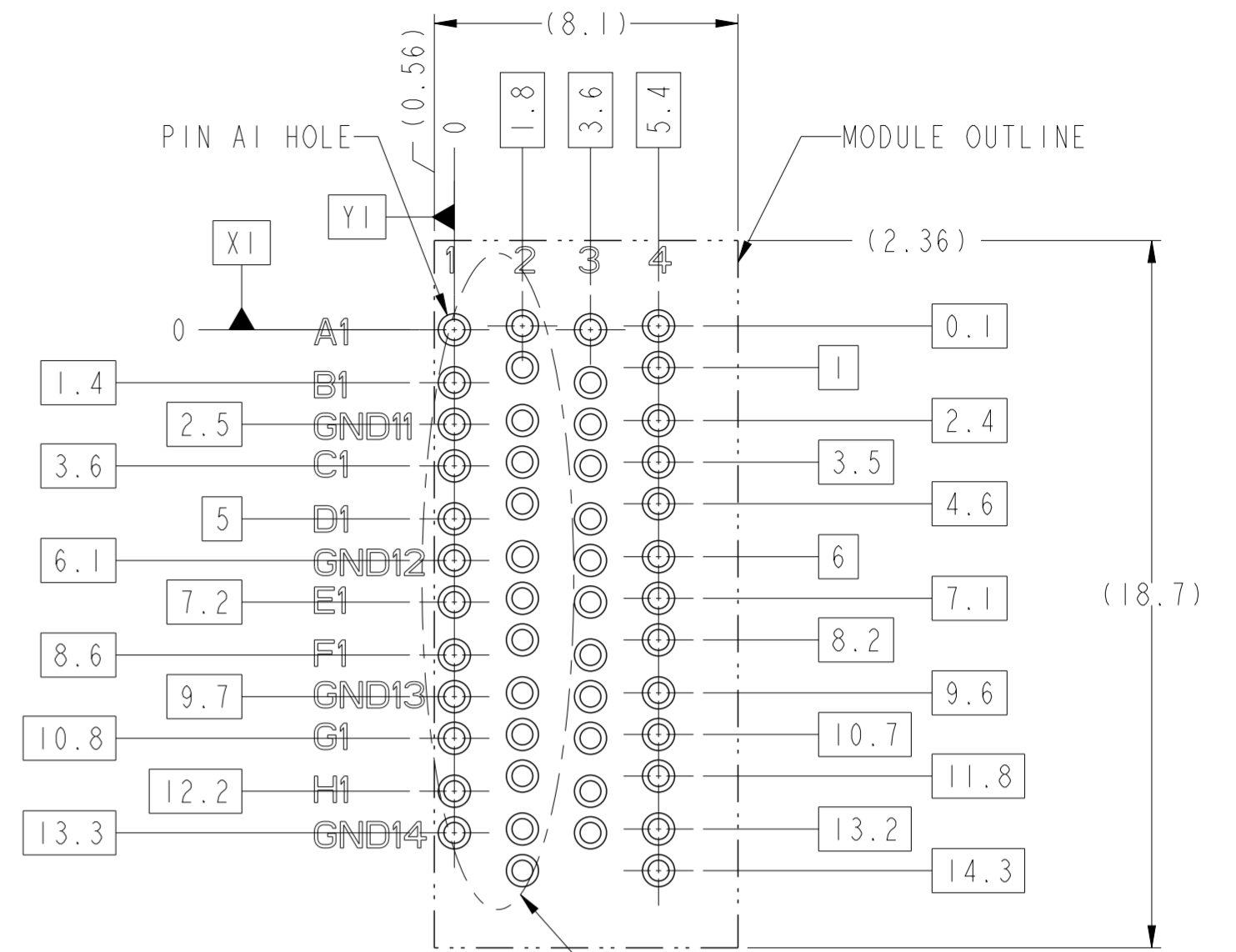

BP HOLE PATTERN COMPONENT SIDE

RIGHT WALL MODULE BACKPLANE FOOTPRINT

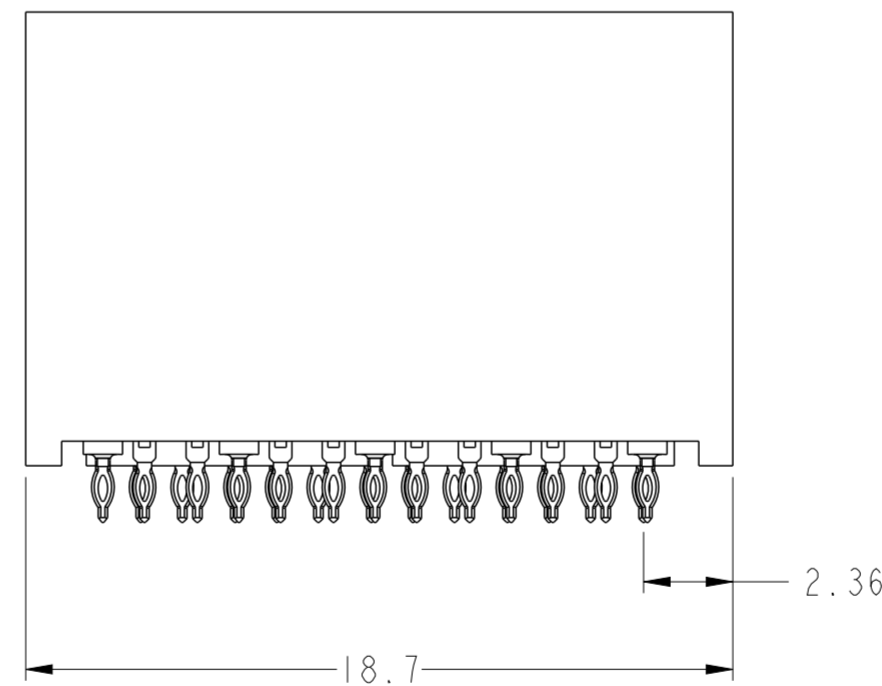
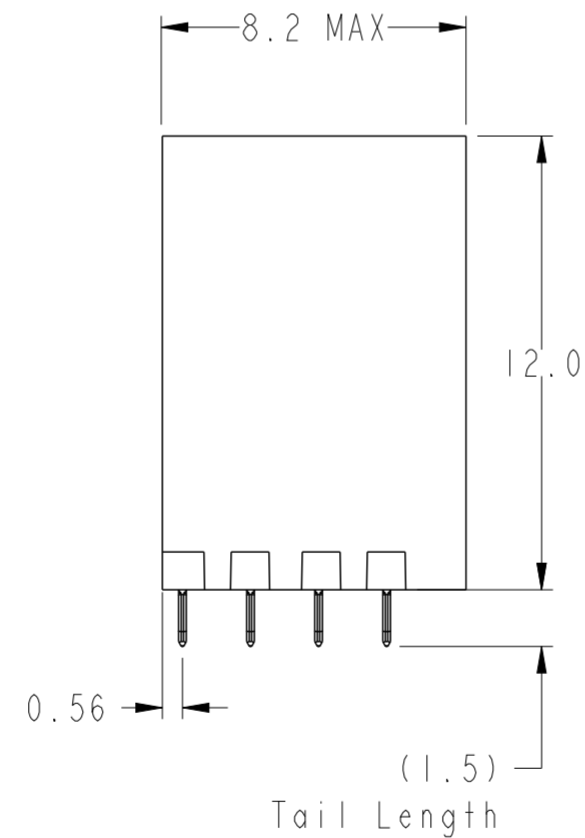
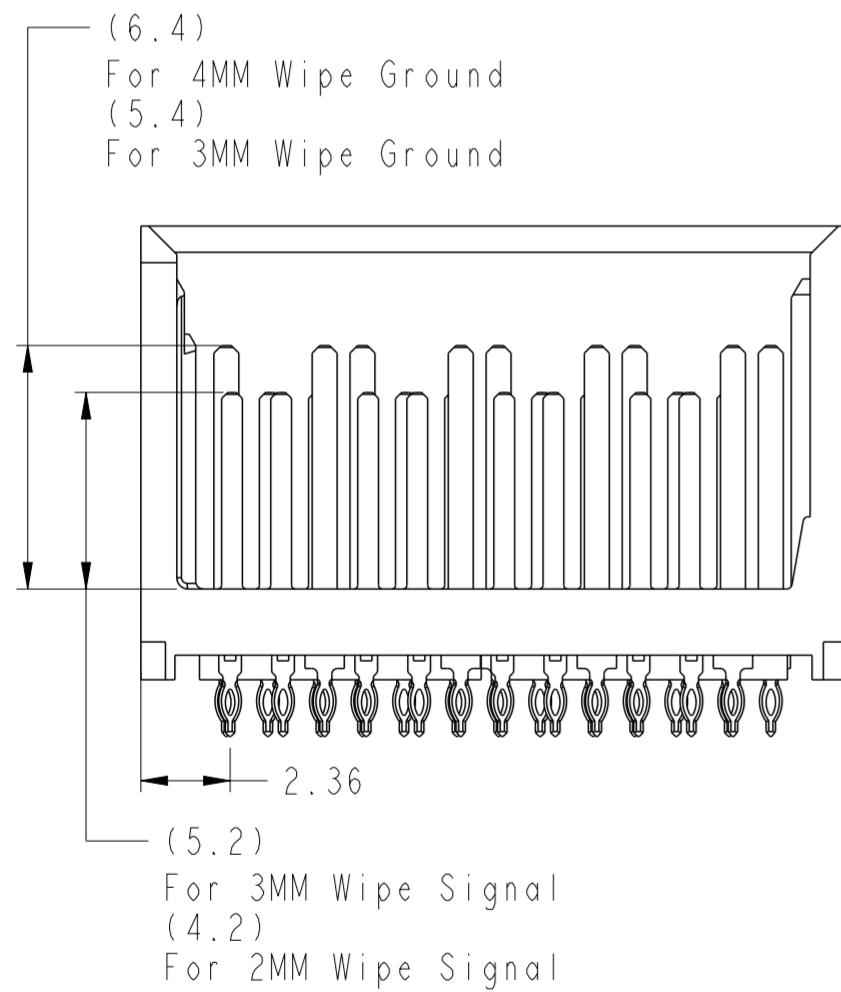

spec ref	-	dr	Yong-Keat Lim	2012/03/05	projection	mm	size	A2	scale	1:1
tolerance std	ISO 406 ISO 1101	eng	Sandar Soe	2016/03/07			ecn no	ELX-S-17624-1		
TOLERANCES UNLESS OTHERWISE SPECIFIED		chr	-	rel level				Released		
surface	ISO 1302	appr	Chen-Hong Tan	2016/03/17	product family	-	rel level	Released		
linear	0.X ±0.3 0.XX ±0.10 0.XXX ±0.05			MODULE ASSEMBLY, XCEDE HD Vertical Header, 4 Pair 4 Column		cat. no.	Product - Customer Drw	sheet 4 of 8	rev C	
angular	0° ±2°	www.fci.com		PDS: Rev :C		STATUS:Released		Printed: Mar 17, 2016		

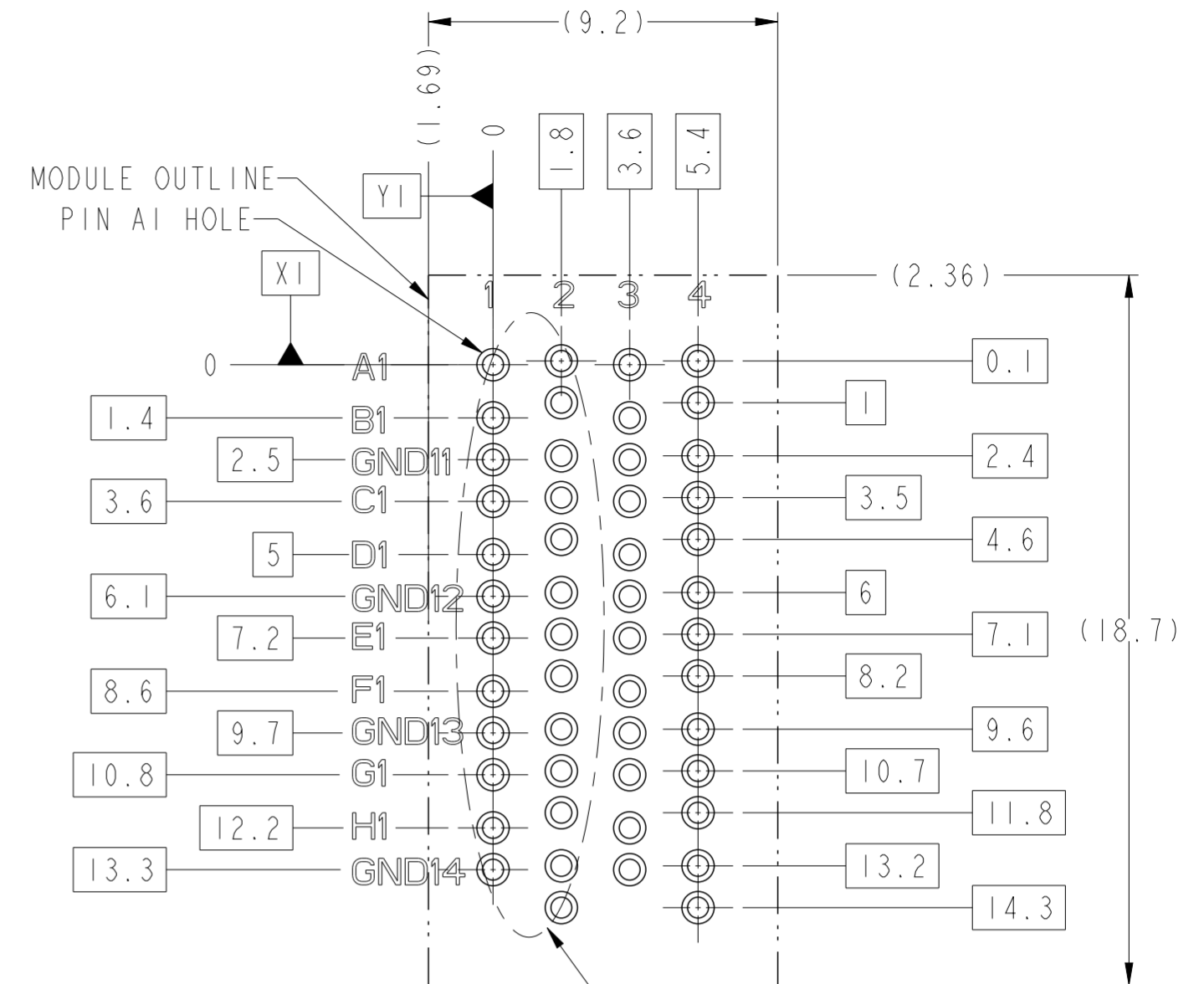
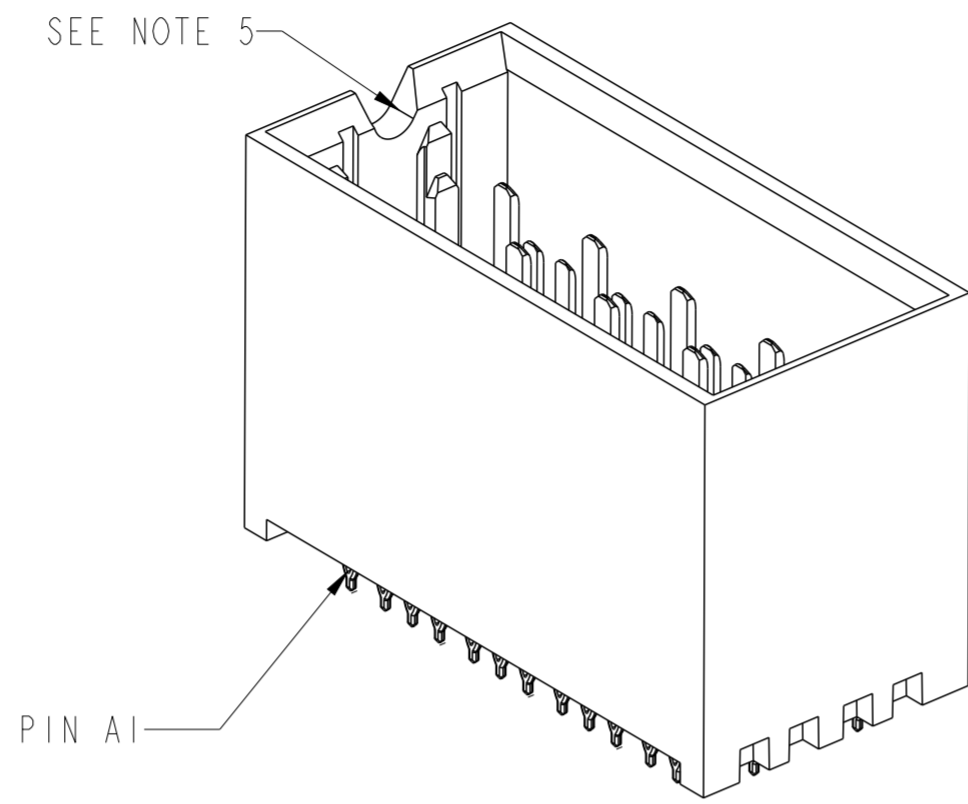
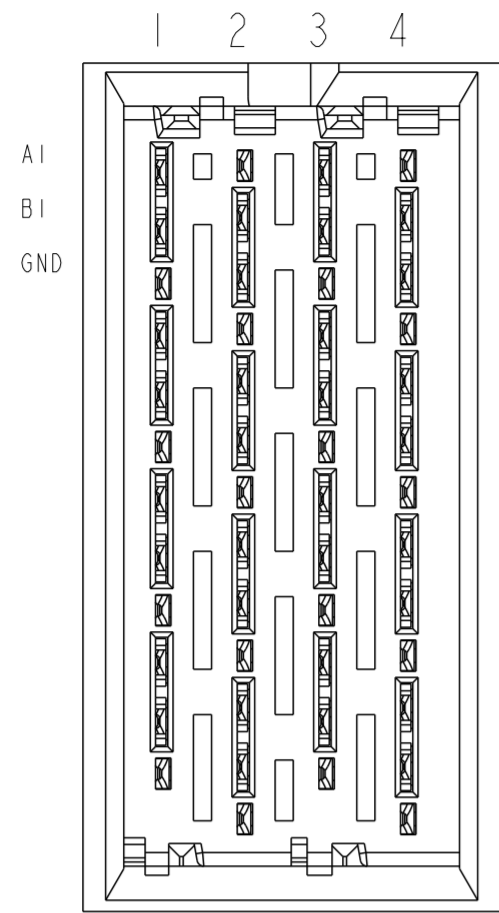

△ FOUR WALL MODULE

SEE DETAIL A
On Sheet 8 For Details

BP HOLE PATTERN COMPONENT SIDE

△ FOUR WALL MODULE BACKPLANE FOOTPRINT

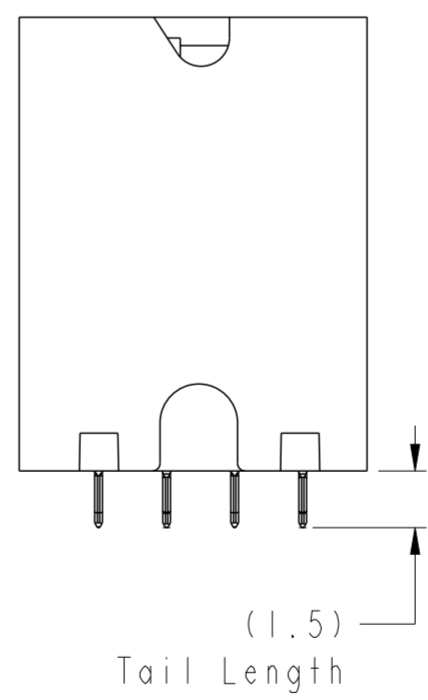
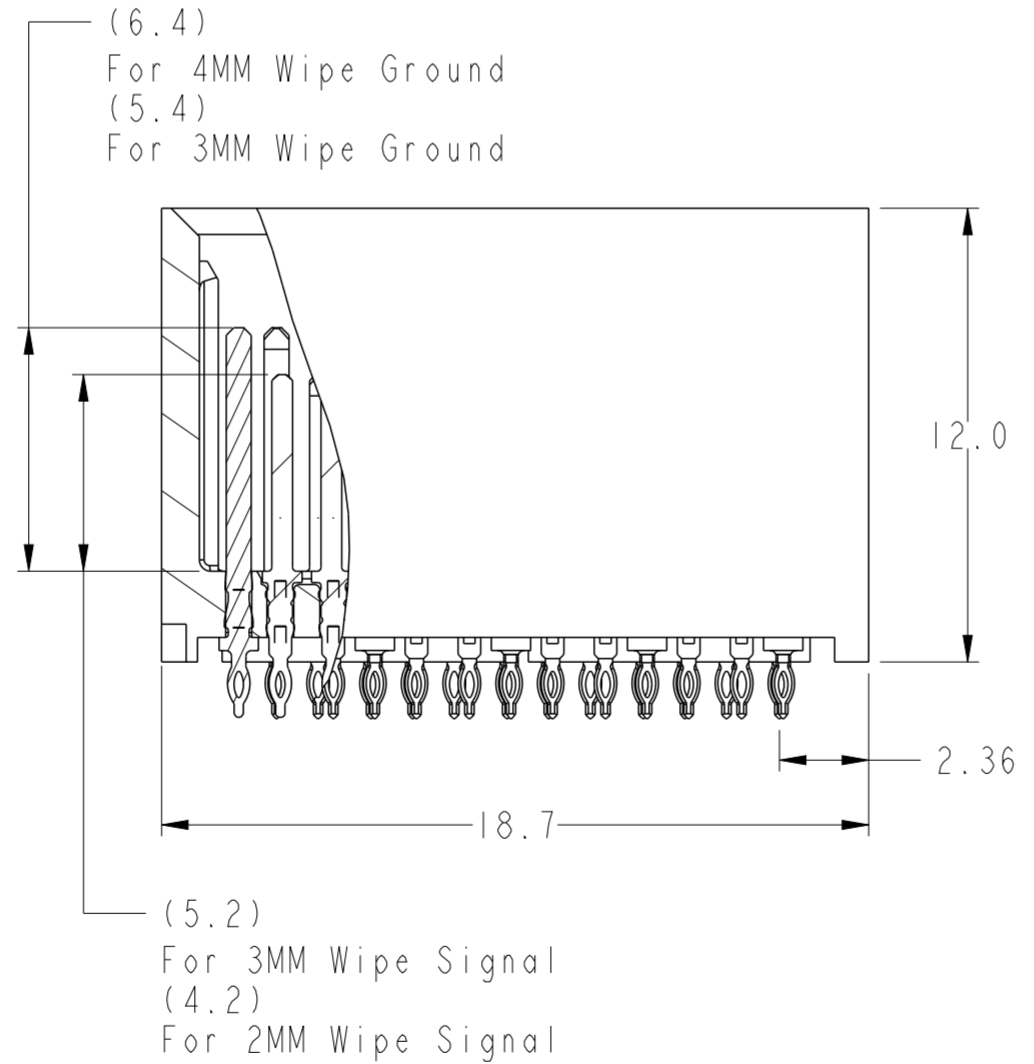
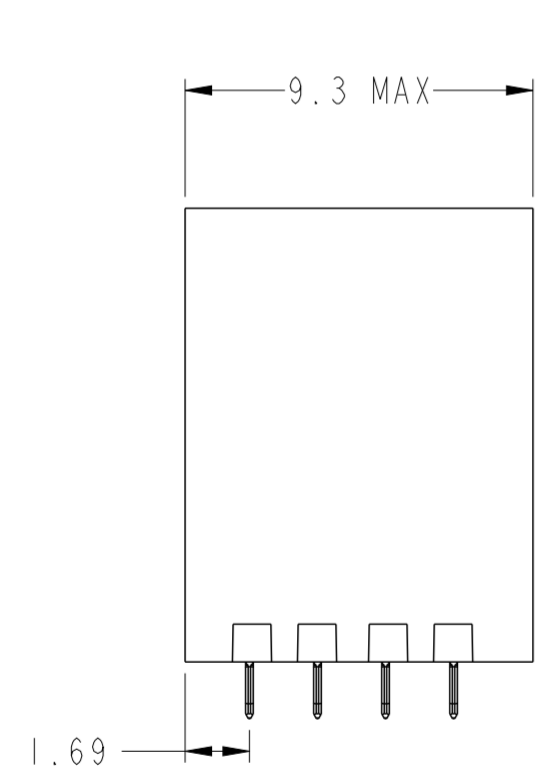

spec ref	-	dr	Yong-Keat Lim	2012/03/05	projection	mm	size	A2	scale	1:1
tolerance std	ISO 406 ISO 1101	eng	Sandar Soe	2016/03/07		mm	ecn no	ELX-S-17624-1	rel level	Released
TOLERANCES UNLESS OTHERWISE SPECIFIED		chr	-	appr						
surface	ISO 1302	linear	0.X	±0.3			title	MODULE ASSEMBLY, XCEDE HD	dwg no	10120126
			0.XX	±0.10	www.fci.com		Vertical Header, 4 Pair 4 Column		rev	C
		angular	0°	±2°	cat. no.		Product - Customer Drw	sheet 5 of 8		

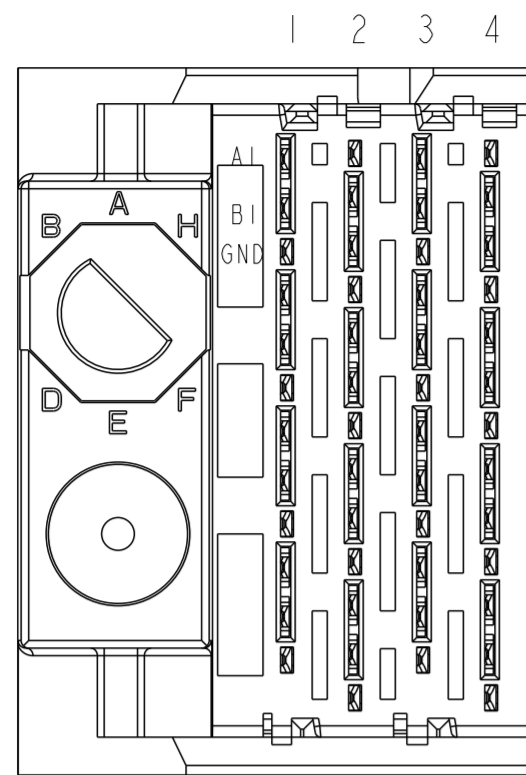

Optional Key See Sheet
1 Part Number Tree

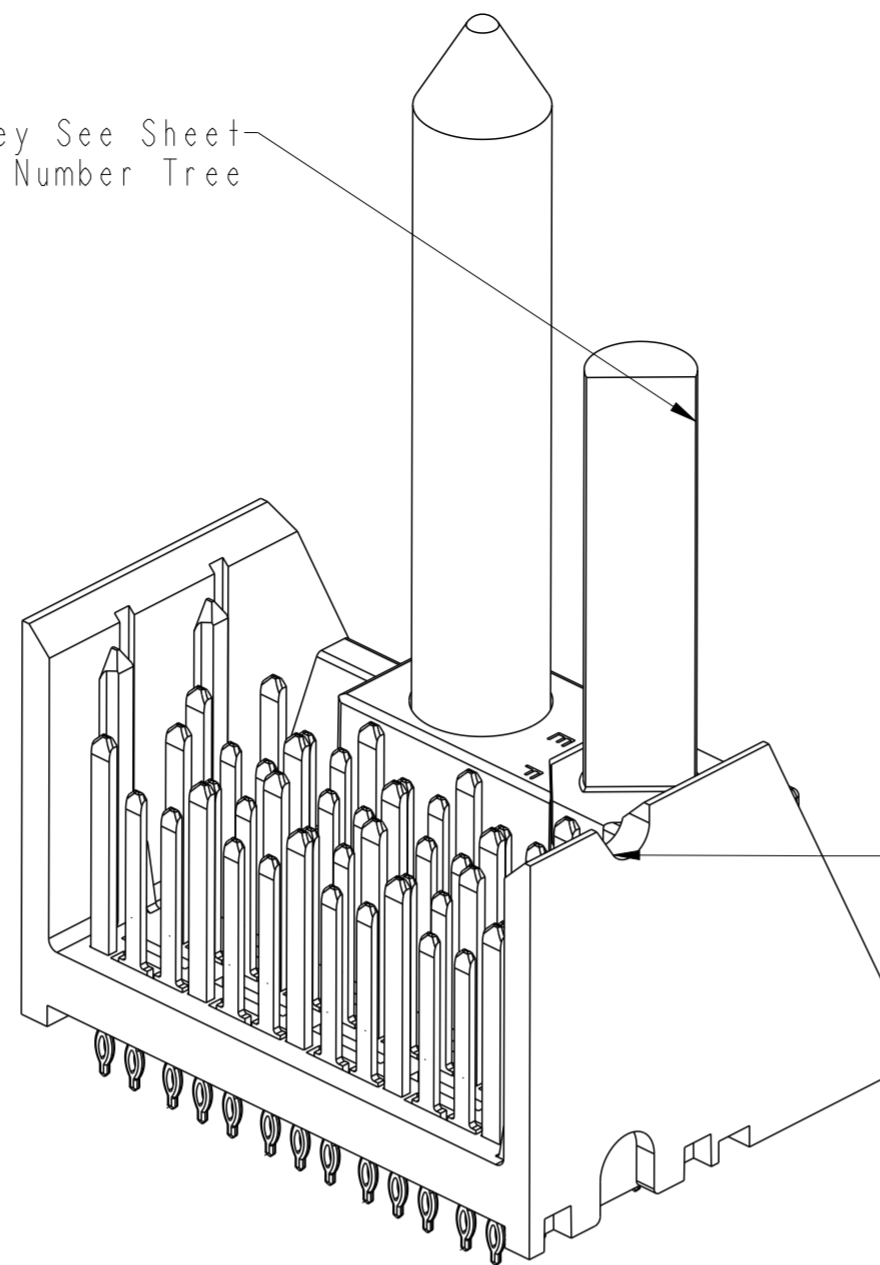

SEE NOTE 5

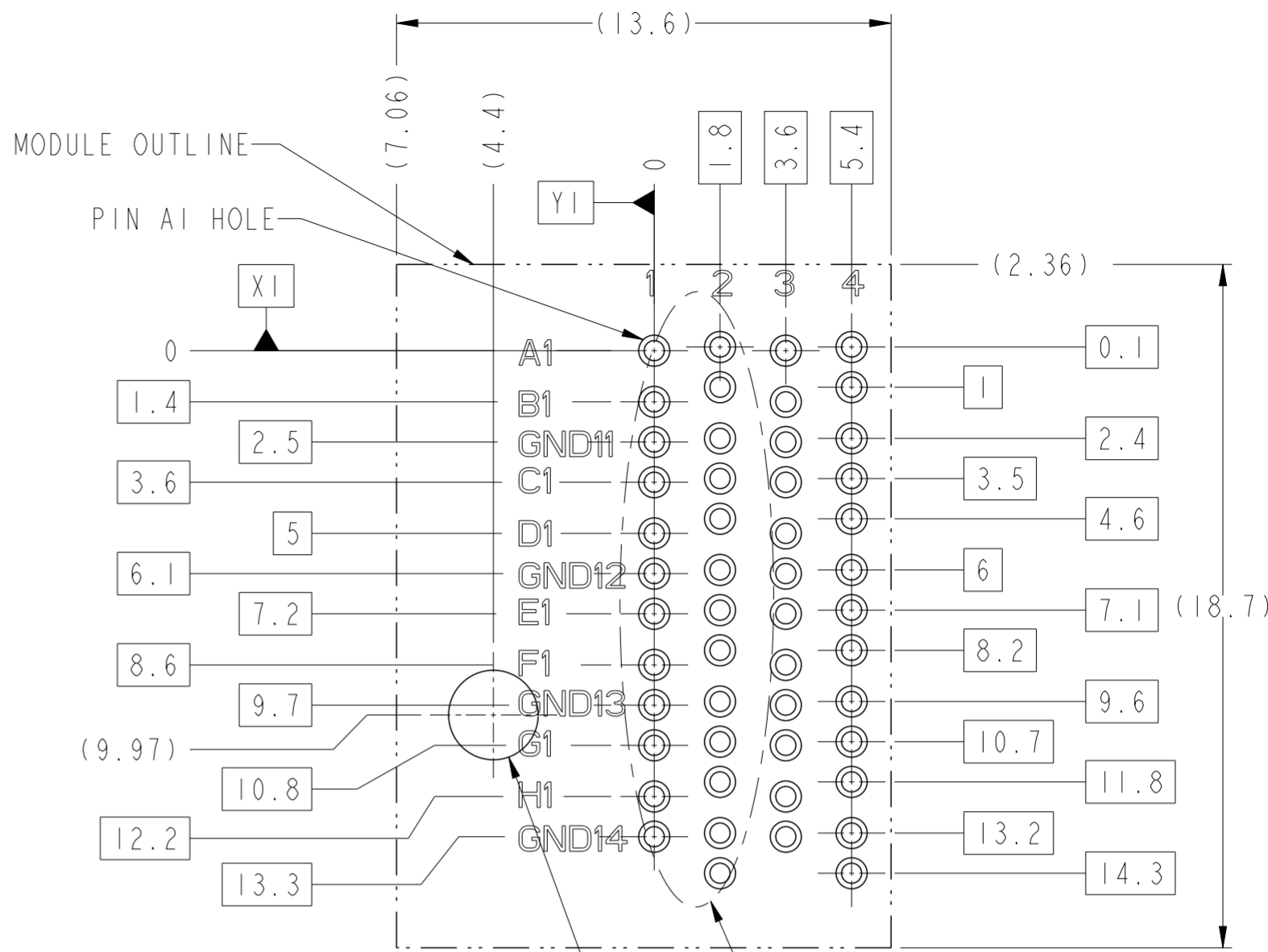

SEE DETAIL A
OnSheet 8 For Details

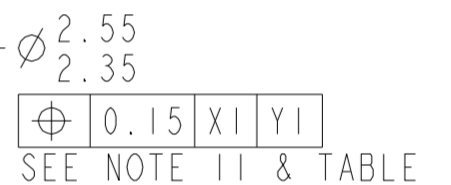

BP HOLE PATTERN COMPONENT SIDE

**LEFT POLARIZING GUIDE MODULE
BACKPLANE FOOTPRINT**

28.5±0.3

(1.5)
Tail Length

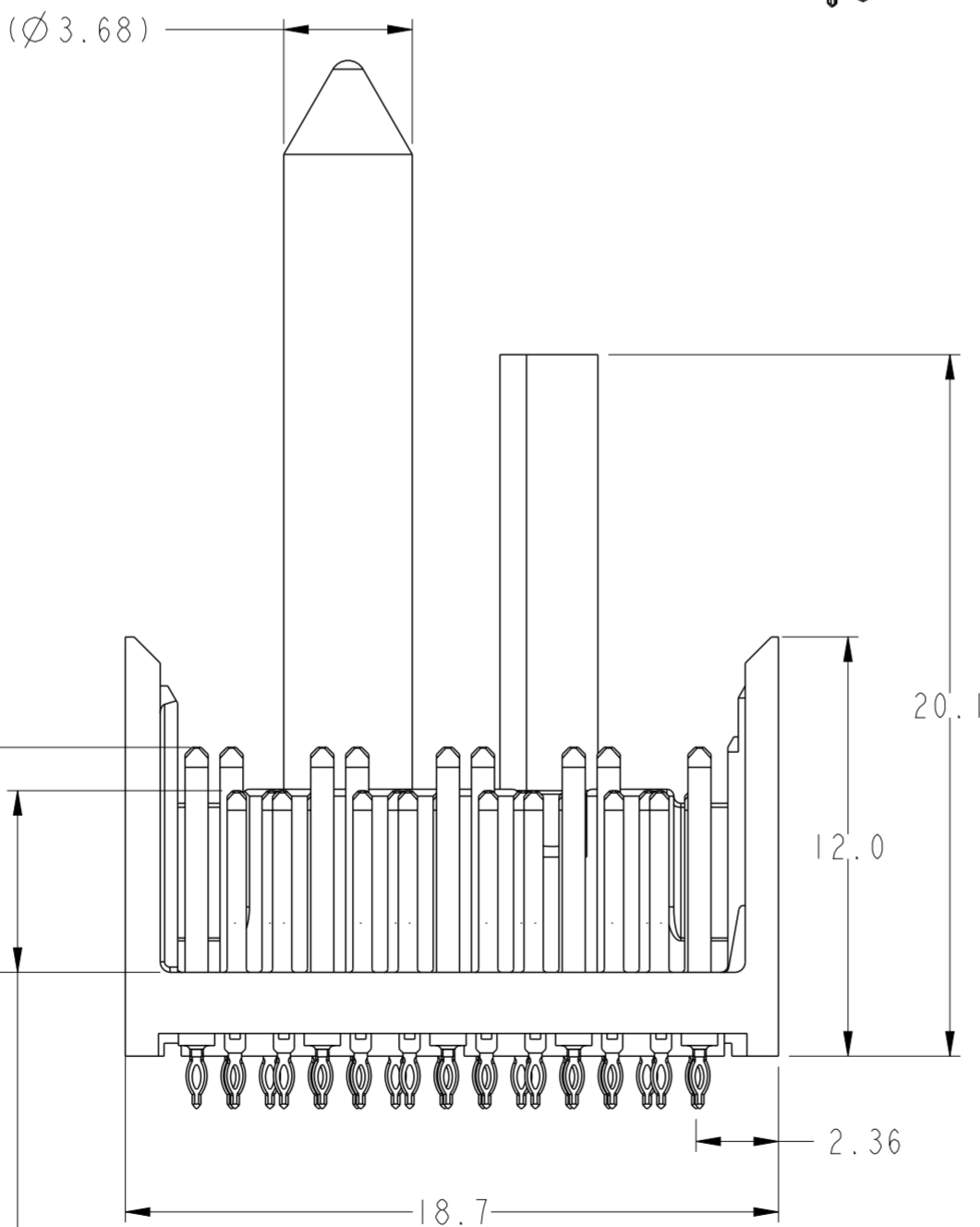
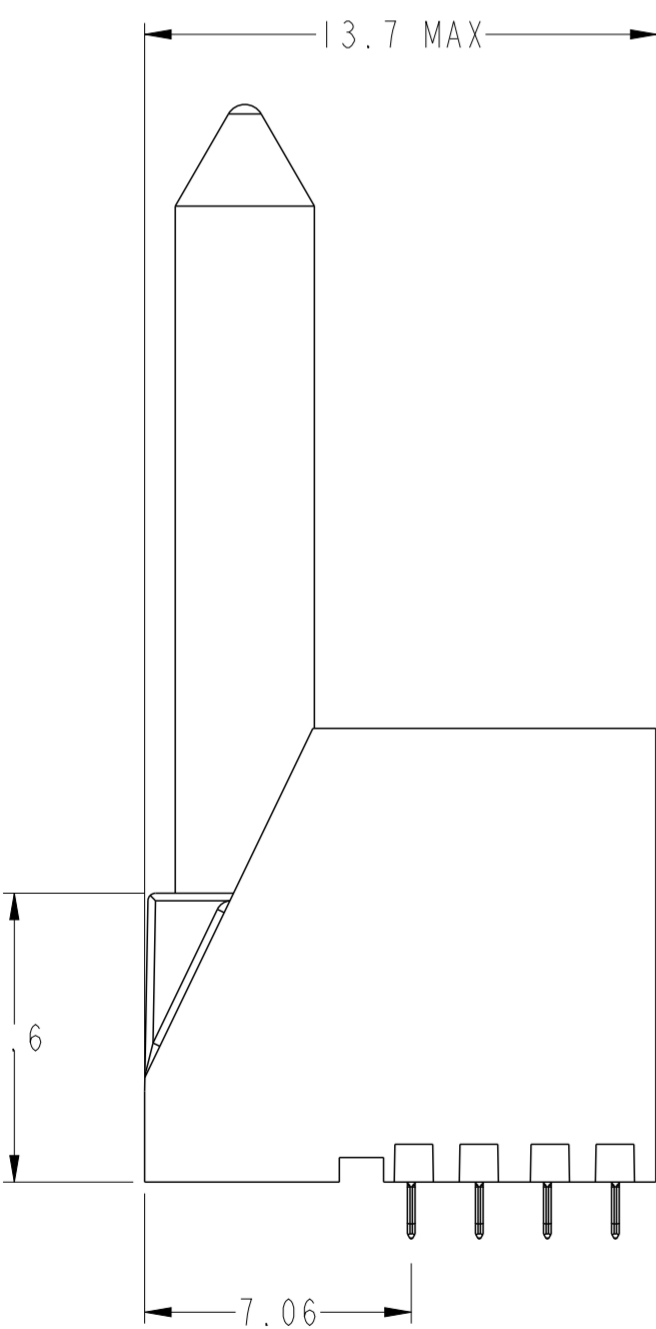

(5.2)
For 3MM Wipe Signal
(4.2)
For 2MM Wipe Signal
(6.4)
For 4MM Wipe Ground
(5.4)
For 3MM Wipe Ground

spec ref	-	dr	Yong-Keat Lim	2012/03/05	projection	mm	size	A2	scale	1:1
tolerance std	ISO 406 ISO 1101	eng	Sander Soe	2016/03/07		mm	ecn no	ELX-S-17624-1		
TOLERANCES UNLESS OTHERWISE SPECIFIED		chr	-	rel level				Released		
surface	ISO 1302	appr	Chen-Hong Tan	2016/03/17	product family	-	rel level	Released	rev	C
linear	0.X ±0.3 0.XX ±0.10 0.XXX ±0.05			MODULE ASSEMBLY, XCEDE HD Vertical Header, 4 Pair 4 Column		cat. no.	10120126	Product - Customer Drw	sheet 6 of 8	
angular	0° ±2°	www.fci.com		PDS: Rev :C		STATUS:Released		Printed: Mar 17, 2016		

Amphenol
FCI

© 2016 AFCl

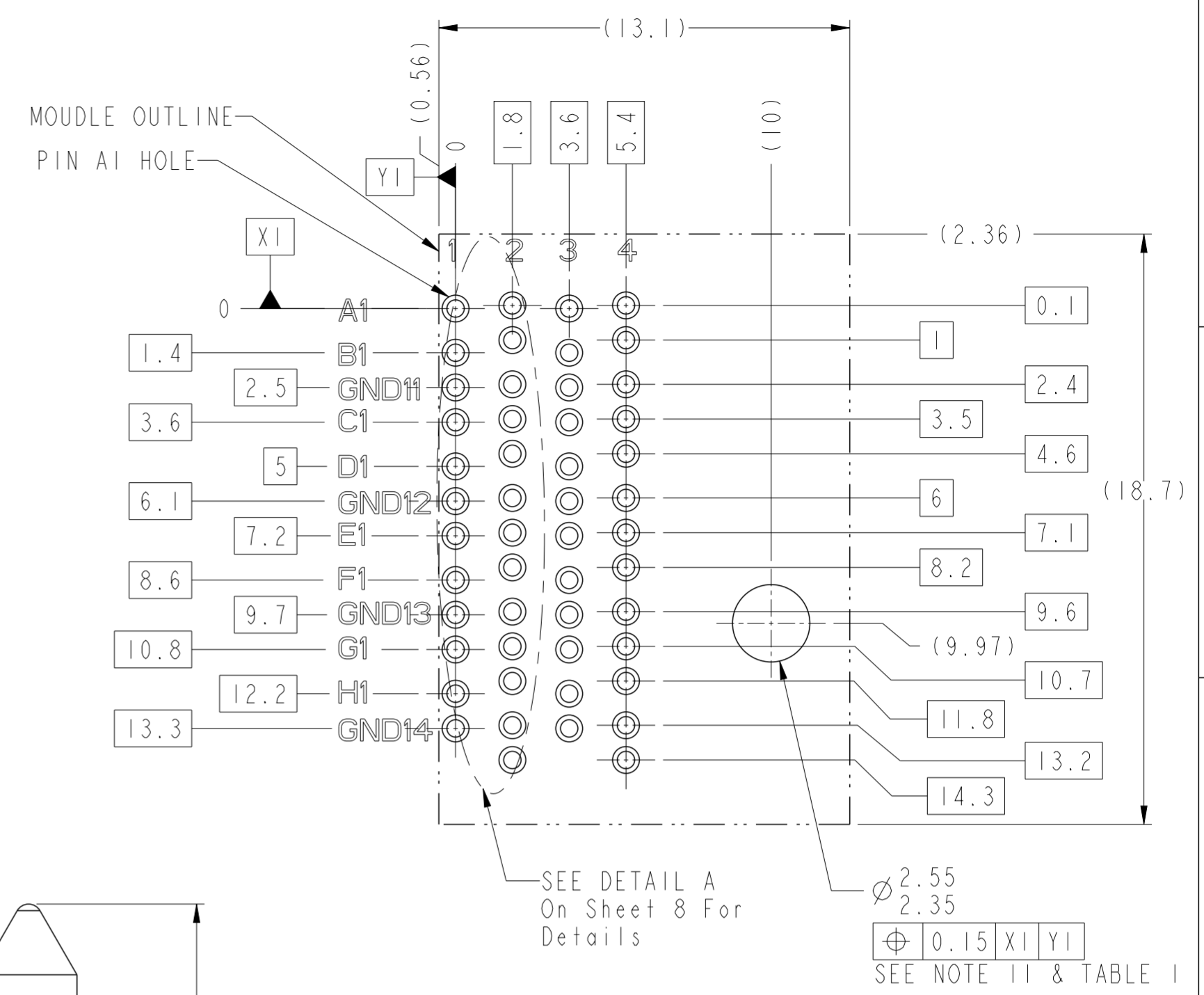
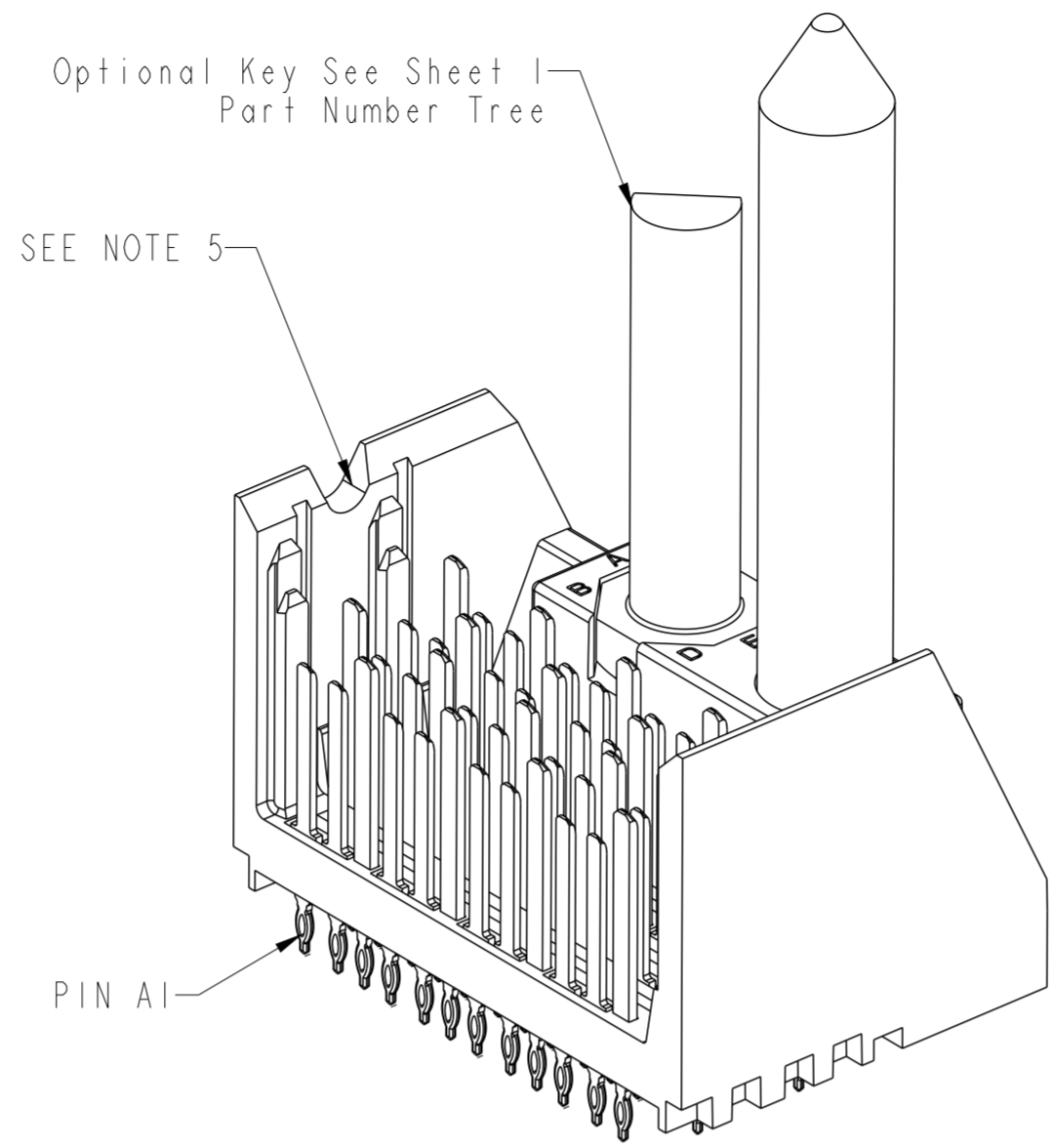
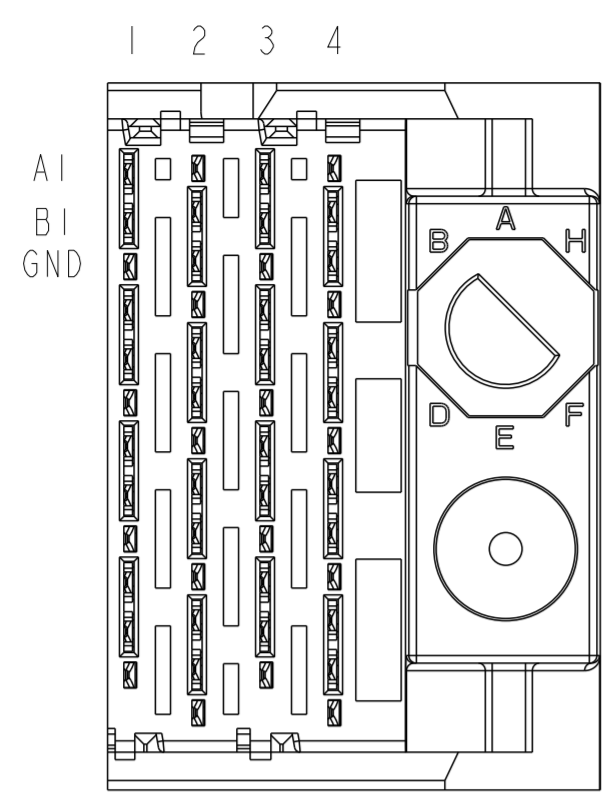

RIGHT POLARIZING/GUIDE MOUDLE

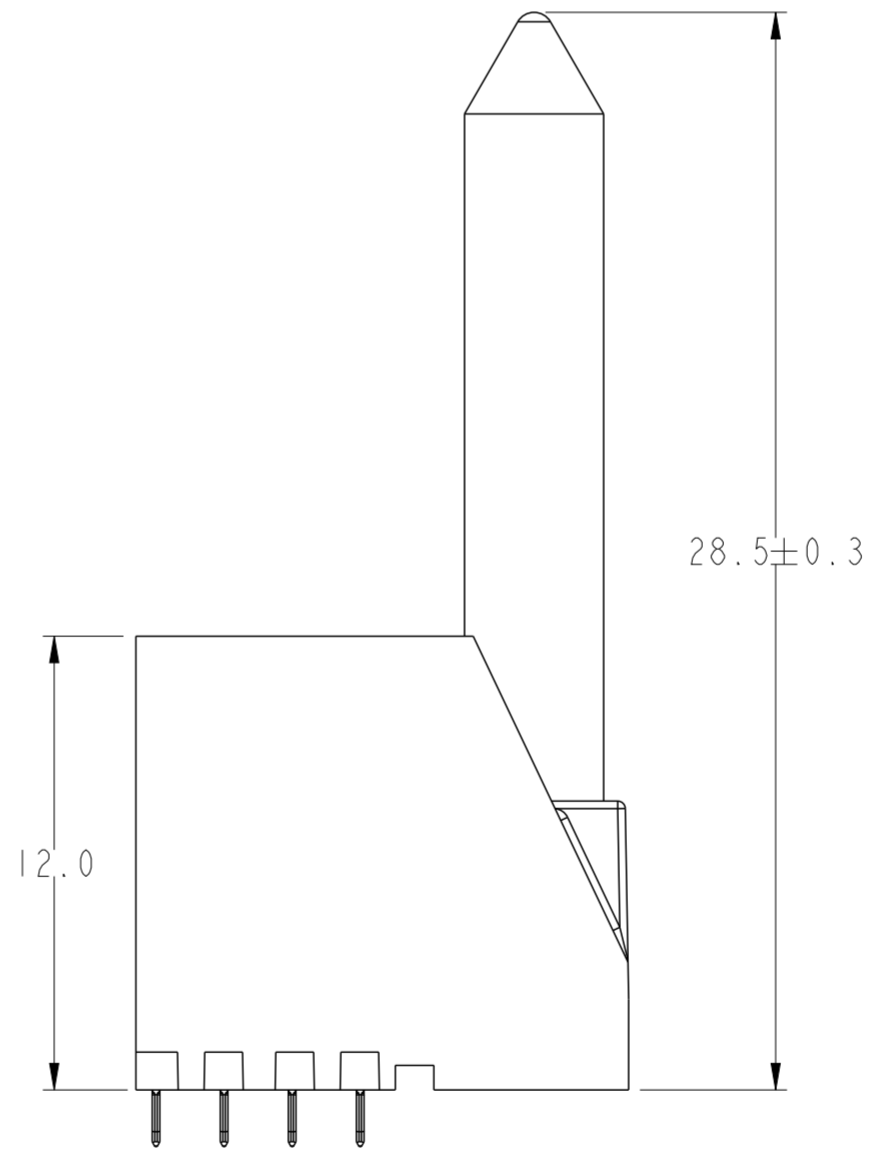
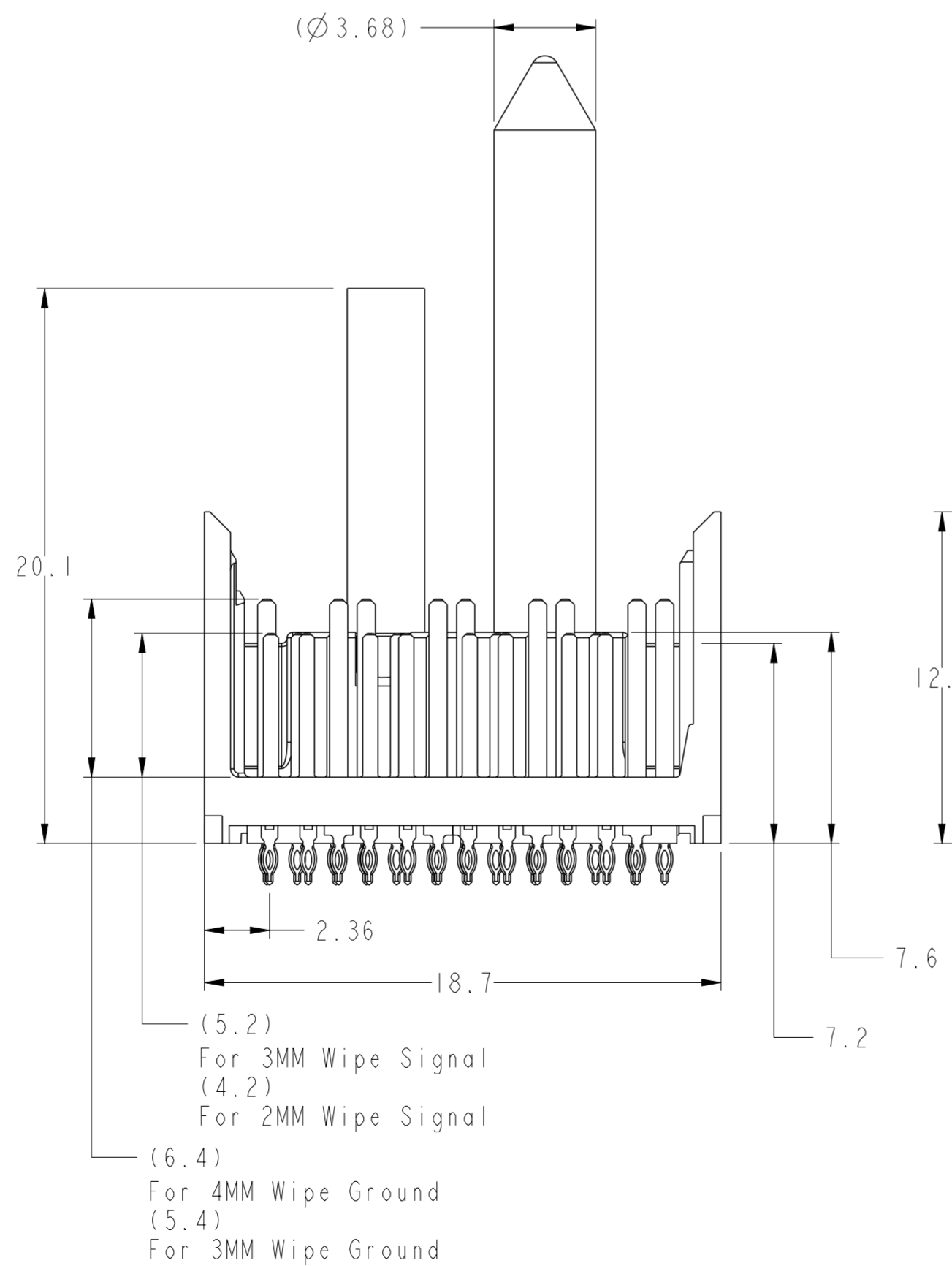
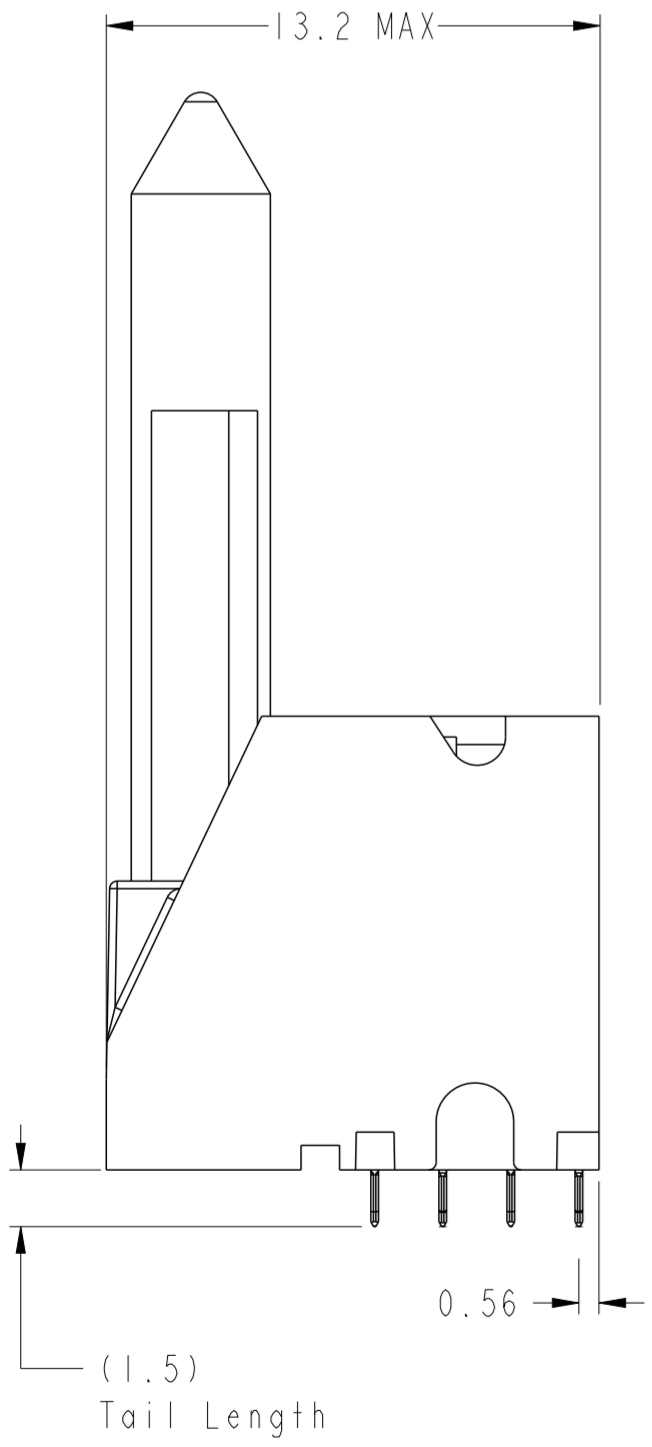

spec ref	-	dr	Yong-Keat Lim	2012/03/05	projection	mm	size	A2	scale	1:1
tolerance std	ISO 406 ISO 1101	eng	Sandar Soe	2016/03/07		mm	ecn no	ELX-S-17624-1	rel level	Released
TOLERANCES UNLESS OTHERWISE SPECIFIED		chr	-	appr						
surface	ISO 1302	linear	0.X	±0.3			cat. no.	10120126	rev	C
		angular	0°	±2°	www.fci.com		Product - Customer Drw	sheet 7 of 8		

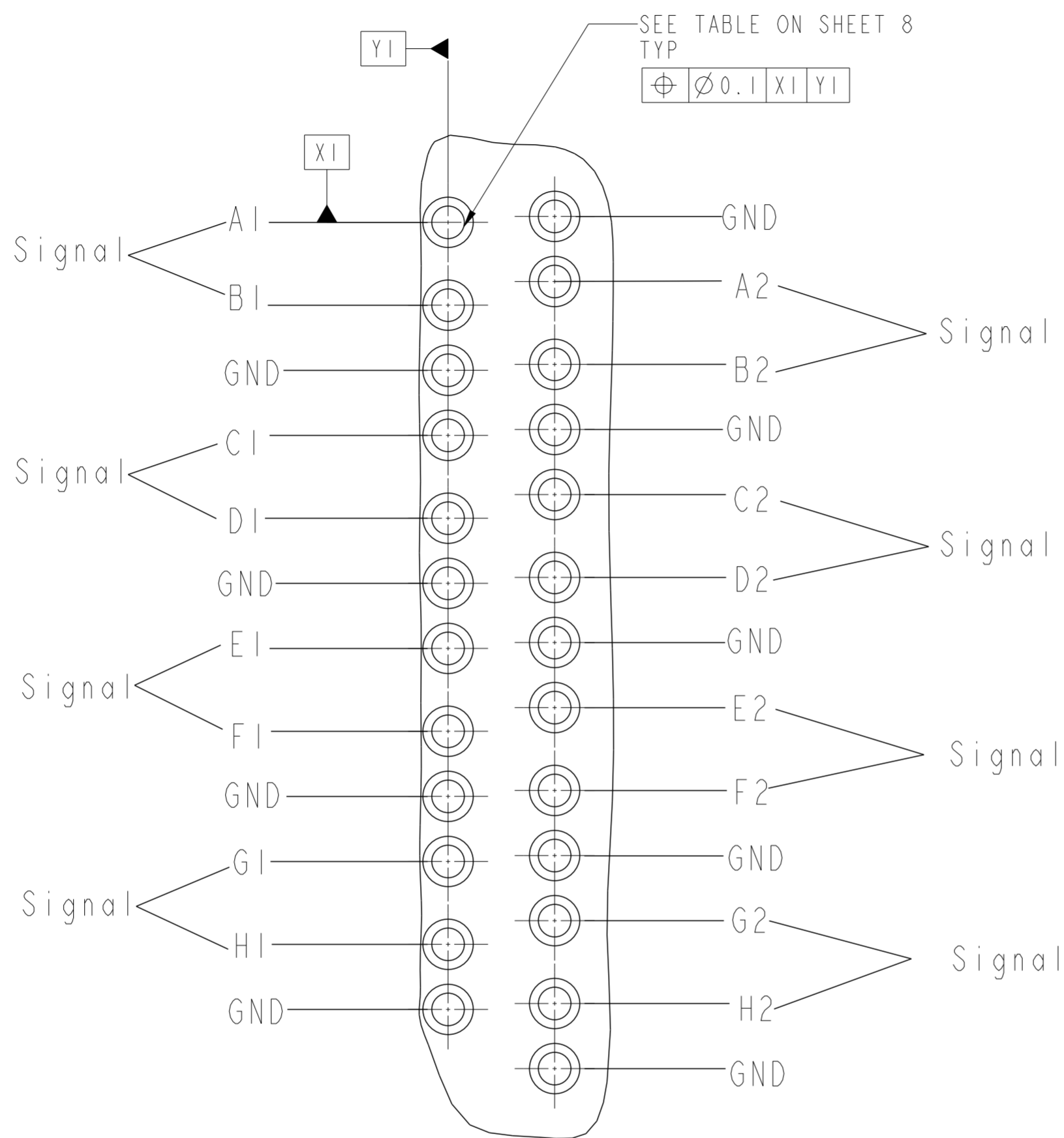

DETAIL A
SCALE 12:1

TABLE 3		
	COMPLIANT PIN DRILL $\varnothing 0.55 [0.0217"]$	COMPLIANT PIN DRILL $\varnothing 0.45 [0.0177"]$
PTH	$\varnothing 0.45 \pm 0.05$	$\varnothing 0.36 \pm 0.05$
DRILL	$\varnothing 0.55 [0.0217"]$	$\varnothing 0.45 [0.0177"]$
PAD	$\varnothing 0.85$	$\varnothing 0.75$

NOTES:

- CONNECTOR MATERIALS
SHROUD : HIGH-TEMP POLYMER, COLOR : BLACK, UL94V-0
CONTACTS : HIGH PERFORMANCE COPPER ALLOY
- PRODUCT SPECIFICATION : GS-12-0936
- APPLICATION SPECIFICATION : GS-20-0348
- PRODUCT MARKING :
PART NUMBER (10120126-X0J-XXXLF)
"FCI" AND DATE CODE (FCI P#####)
- NOTCH DESIGNATES "ROW A" SIDE OF CONNECTOR. NOTCH FEATURE ON OPPOSITE FOR PRODUCT MARKING.
- PLATING THICKNESS OF SIGNAL & GROUND CONTACT ARE DETERMINED BY PLATING CODE, REFER TO P/N TREE ON SHEET 1.
- PACKAGING MEETS GS-14-920 LEAD-FREE LABELING SPECIFICATION.
- GUIDE-PIN STYLE DESIGNATION ONLY APPLIES TO MODULE VERSIONS THAT REQUIRE GUIDE-PIN HARDWARE. FOR ALL NON-GUIDE-PIN VERSIONS, THE DEFAULT DASH-NUMBER DIGIT IN THAT LOCATION IS STILL '0'.
- SEE APPLICATION SPECIFICATION FOR ROUTING GUIDELINES, ADDITIONAL PTH GUIDELINES, MATED DIMENSIONS, GUIDE PIN SELECTION, ETC.
- A $\triangle C$ SYMBOL WILL BE NEXT TO ANY DIMENSION, VIEW OR NOTE THAT HAS BEEN MODIFIED WITH THE CURRENT DRAWING REVISION.
- OPTIONAL HOLE LOCATION FOR GROUNDED PIN OR ADDITIONAL GUIDE-PIN SUPPORT. SEE TABLE 1 SHEET 1 FOR ADDITIONAL DETAILS.
- SCREW IS OPTIONAL AND ENGAGES WITH BOTTOM OF GUIDE PIN FROM BENEATH THE PCB FOR ADDITIONAL GUIDE-PIN SUPPORT.

spec ref	-	dr	Yong-Keat Lim	2012/03/05	projection	mm	size	A2	scale	1:1
tolerance std	ISO 406 ISO 1101	eng	Sandar Soe	2016/03/07		mm	ecn no	ELX-S-17624-1	rel level	Released
TOLERANCES UNLESS OTHERWISE SPECIFIED		chr	-	appr						
surface	ISO 1302	linear	0.X	± 0.3			part no	10120126	rev	C
			0.XX	± 0.10	Amphenol FCI		cat. no.	-	Product - Customer Drw	sheet 8 of 8
		angular	0°	$\pm 2^\circ$	www.fci.com		Module Assembly, XCEDE HD			
			0.XXX	± 0.05	Vertical Header, 4 Pair 4 Column					