

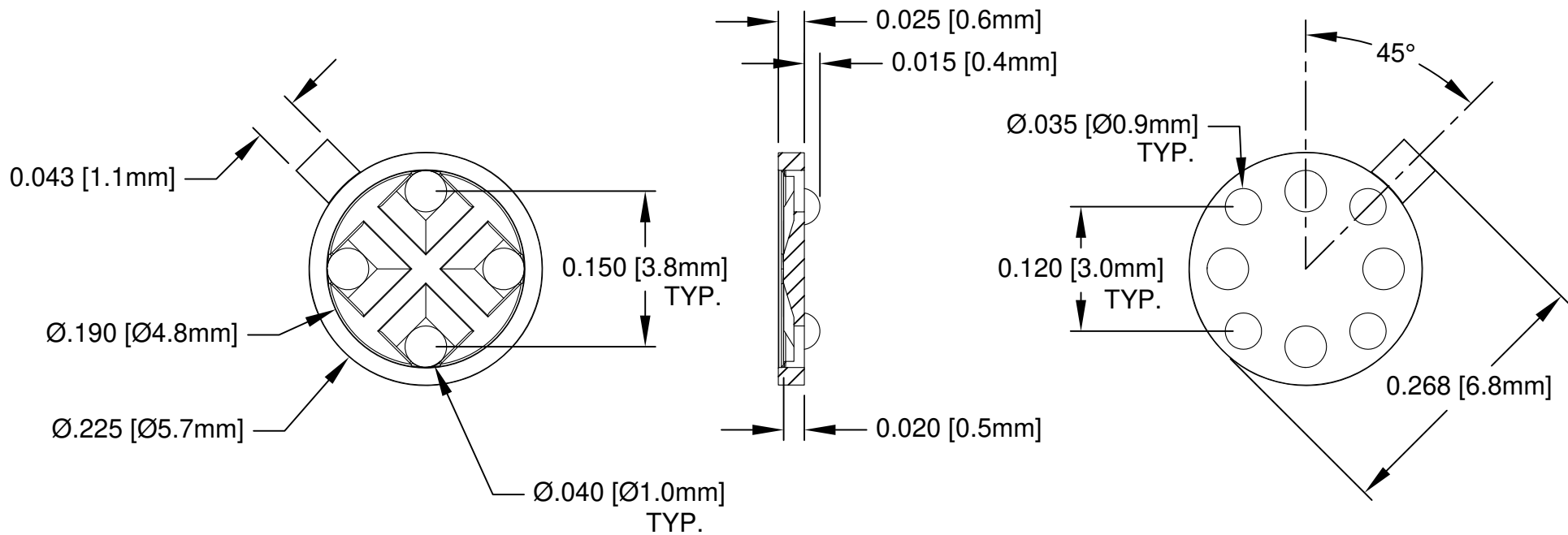

REV.	DESCRIPTION	DATE	APPROVED
A	Engineering Update w/o Changes	02/17/04	M. C.
B	Model Update	11/18/08	T. Y.
C	Removed Material Code	05/23/16	J. C.



2. MATERIAL: NYLON 6/6, 94V-2, NATURAL.

1. GENERAL SPECIFICATIONS: BIVAR MOLDED COMPONENT SPECIFICATION BV00-E101.

STANDARD TOLERANCE ( UNLESS OTHERWISE SPECIFIED )		 4 THOMAS, IRVINE, CA. 92618 TEL: (949) 951-8808 FAX: (949) 951-3974	
DECIMALS	ANGULAR		
.X ±.1	X° ±1°	<b>TITLE:</b> PERM-O-PAD TO-18 MOUNT	
.XX ±.01			
.XXX ±.005			
DESIGNED: <b>S. Irving</b>	DATE: <b>06/30/98</b>	<b>PART NO:</b> 211-040	REVISION: <b>C</b>
CHECKED: <b>D. Green</b>	DATE: <b>02/17/04</b>	<b>CAGE CODE : 32559</b>	<b>SHEET # 1 OF 1</b>
CAD GENERATED DOCUMENT, DO NOT MEASURE DRAWING.			