

THIS DRAWING IS UNPUBLISHED. RELEASED FOR PUBLICATION
 © COPYRIGHT BY TYCO ELECTRONICS CORPORATION. ALL RIGHTS RESERVED.

LOC	DIST	REVISIONS					
		P	LTR	DESCRIPTION	DATE	DWN	APVD
G	14		N	REV PER OG3A-0279-03	02SEP03	JR	MS

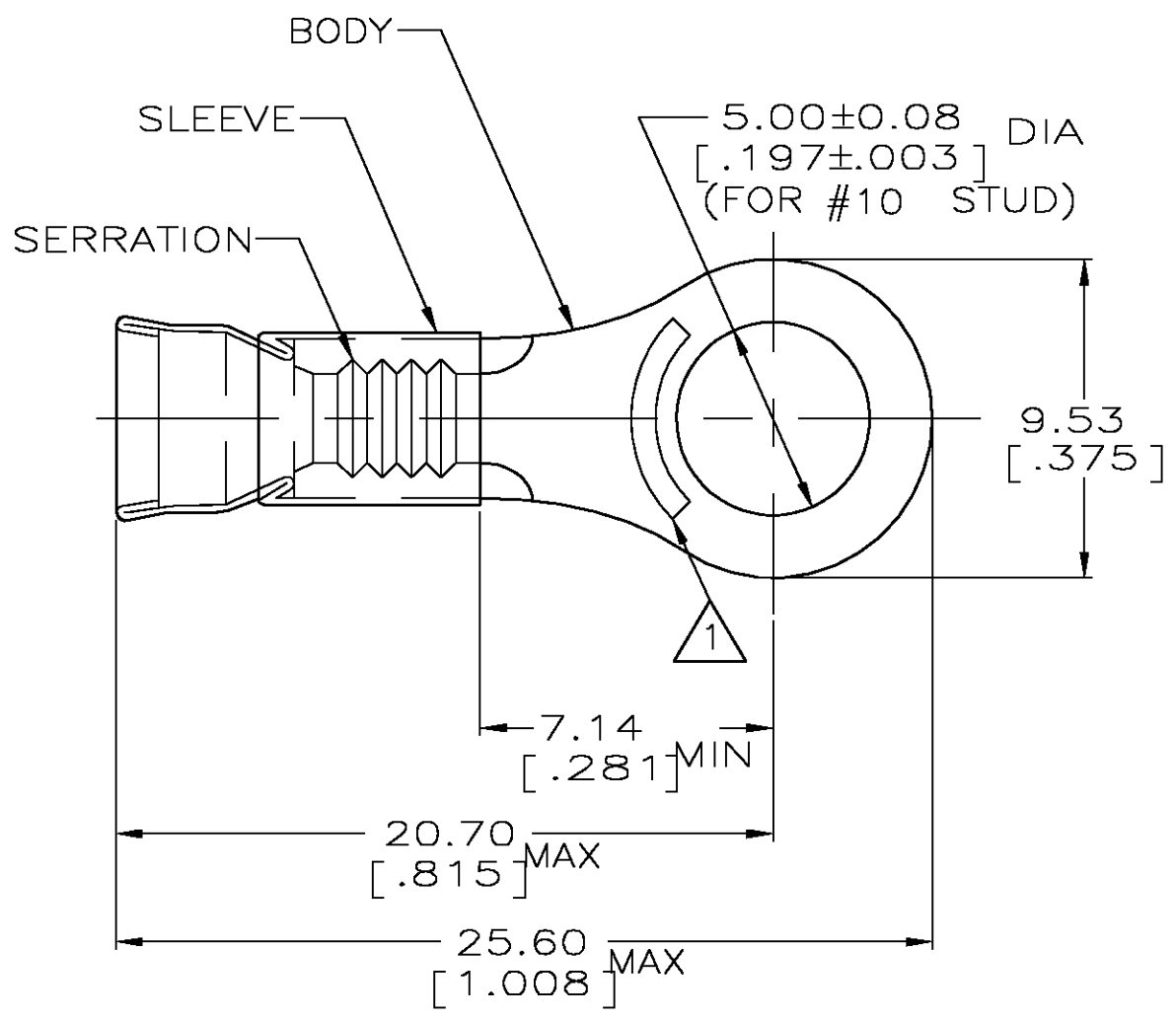

- 1 SEE TABLE FOR STAMPING
- 2 WIRE INSUL. DIA 3.18-5.84 [.150-.230]
- 3 TONGUE MATL THK, 1.02±0.05 [.040±.002]
- 4 MATERIAL: BODY - SEE TABLE
SLEEVE - NI SIL PER ASTM B122
- 5 MAX RECOMMENDED OPERATING TEMP
649°C [1200°F]
- 6 CIRCULAR MIL AREA 2.62mm² -6.64mm²
[5180-13100] STARNDDED WIRE

	AMP 12-10	NICKEL PER ASTM B162	ORANGE	2500	ON TAPE, REEL	2-323750-5
OBSOLETE	AMP 12-10AL	ALUMEL	GREEN	500	LOOSE PIECE	2-323750-1
	AMP 12-10	NICKEL PER ASTM B162	ORANGE	500	LOOSE PIECE	323750
	STAMPING	BODY MATERIAL	SLV COLOR	QTY	PACKAGE TYPE	PART NO

THIS DRAWING IS A CONTROLLED DOCUMENT.		DWN L OLMEDA 10OCT94	Tyco Electronics Corporation Harrisburg, PA 17105							
DIMENSIONS: MM [INCHES]		CHK M ELLIS 10OCT94					NAME			
		APVD S BORTNER 10OCT94					PRODUCT SPEC			
TOLERANCES UNLESS OTHERWISE SPECIFIED:		APPLICATION SPEC		TERMINAL, RING TONGUE, STRATO-THERM, DIAMOND GRIP WIRE SIZE 12-10 AWG						
0 PLC ± -		WEIGHT -		SIZE A3	CAGE CODE 00779	DRAWING NO C-323750				
1 PLC ± -		CUSTOMER DRAWING		SCALE 4:1	SHEET 1 OF 1	REV N				
2 PLC ± 0.20 [.008]										
3 PLC ± -										
4 PLC ± -										
ANGLES ± -										
MATERIAL - 4		FINISH SEE TABLE								