

THIS COPY IS PROVIDED ON A RESTRICTED BASIS AND IS NOT TO BE USED IN ANY WAY DETRIMENTAL TO THE INTERESTS OF PANDUIT CORP.

WIRE SIZE	NUMBER OF WIRES	NUMBER OF ADDITIONAL WIRES OF ONE SIZE					
		#24	#22	#20	#18	#16	#14
#24 AWG	1	1-10	1-6	1-4	1 OR 2	1	1
	2	1-9	1-5	1-3	1 OR 2	1	1
	3	1-8	1-4	1 OR 2	1 OR 2	1	0
	4	1-7	1-4	1 OR 2	1	1	0
	5	1-6	1-3	1	1	0	0
	6	1-5	1-3	1	0	0	0
	7	1-4	1 OR 2	0	0	0	0
#22 AWG	1	1-10	1-5	1-4	1 OR 2	1	1
	2	1-8	1-4	1-3	1 OR 2	1	0
	3	1-6	1-3	1 OR 2	1	1	0
	4	1-4	1 OR 2	1	1	0	0
	5	1 OR 2	1	1	0	0	0
#20 AWG	1	1-6	1-4	1-4	1 OR 2	1	1
	2	1-4	1-3	1-3	1 OR 2	1	0
	3	1 OR 2	1 OR 2	1 OR 2	1	0	0
	4	1	1	1	0	0	0
#18 AWG	1	1-5	1-4	1-3	1 OR 2	1	0
	2	1-3	1 OR 2	1 OR 2	1	0	0
#16 AWG	1	1-4	1-3	1 OR 2	1	1	0
#14 AWG	1	1 OR 2	1	1	0	0	0

- USED FOR:
 - FOR SOLID OR STRANDED COPPER WIRE
 - 600V MAX BUILDING WIRE, (1000V. MAX IN SIGNS, FIXTURES, AND LUMINAIRES)
 - 221°F (105°C) MAX TEMP RATING
 - SEE CHART FOR WIRE COMBINATIONS
 - WIRE COMBINATIONS USING #24 AWG WIRE ARE NOT UL LISTED OR CSA CERTIFIED
- SEE www.panduit.com FOR PART NUMBER SUFFIX DESIGNATION FOR PACKAGE SIZE.
- DIMENSIONS IN BRACKETS ARE METRIC EQUIVALENT
- INSTALLATION TOOLS:
 - UL LISTED AND CSA CERTIFIED: CT-500, CT-1550, CT-1551, CT-2400, CT-2500 (CT-2550CH), CT-600-A (CT-500CH)
 - PANDUIT APPROVED: CT-100A, CT-160, CT-250, CT-260, CT-400, CT-550

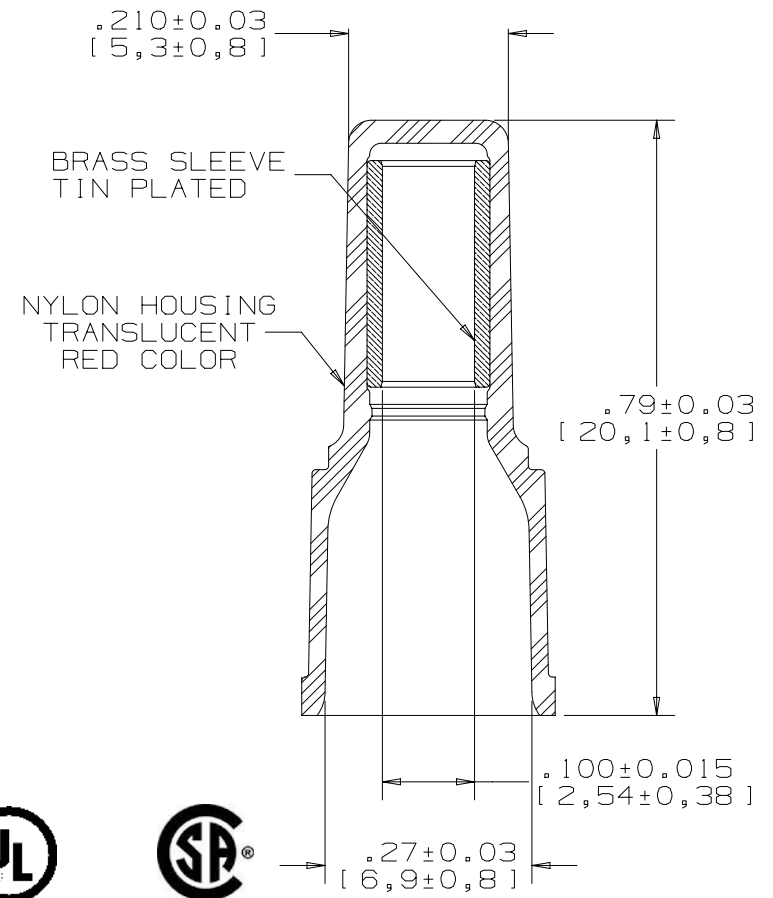

TITLE		NYLON INSULATED WIRE JOINT JN224-318	
ITEM REVISION NAME		CUSTOMER DRAWING	
DATASET FILE NAME		N41341BA/06	
UNLESS OTHERWISE SPECIFIED, DIMENSIONAL TOLERANCES ARE: IN (mm)		MATERIAL:	
.x ± .1 [2.54] .xx ± .01 [.25]		SEE NOTES	
.xxx ± .005 [.127] ANGLES ± 5 °		DRAWING NUMBER:	
THIRD ANGLE PROJECTION		A41341	
DRAWN BY	DATE	CHK	SCALE
TSM		TRS	NONE
SHT 1 OF 1		SIZE	
		A	

REV	DATE	BY	CHK	APR	DESCRIPTION	ECN
06	6/15	TMR	TMR	RGB	ADD TOL DIMS, REMOVE SLEEVE THK, REVISED UL TOOL INFO	N41341BA-DC
05	8/11	SHOR			MODIFIED NOTE #2	

D10100DA/16