

CMK-R

INDUSTRY STANDARD APPLICATOR

OPERATION
MANUAL

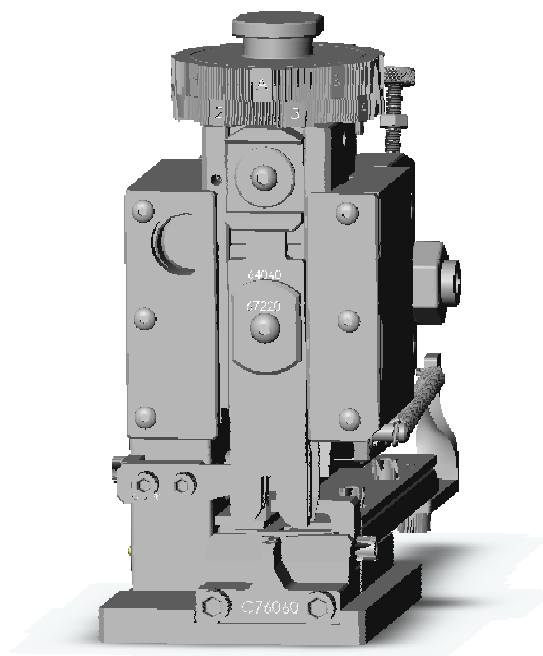

JST
The Quality Connection

For safe use

- Always switch off the Press at the mains and remove the applicator from the Press before making any adjustments or fitting new parts.
- Always refer to this manual before making any adjustments to JST Applicators
- All JST Applicators are supplied with a Die-construction sheet, please refer to this document when ordering spare parts.
- All JST Industry standard Applicators have been designed to operate in Industry standard presses with a shut height of 135.78mm. If you have any doubt to whether our applicator is compatible with your Press please do not hesitate to call our Technical Services Department where one of our Engineers will be pleased to advise.
- Do not modify or adapt the applicator without prior consent of JST.
- Always ensure that safety guards are fitted to the Press when using your JST applicator.
- To prevent damage to the dies, always ensure that a protective rubber collar is fitted between the dials and casting of the applicator when it is removed from the press.

CONTENTS

	Page
1. Ram Slide Section.....	4
2. Shear Blade.....	5
3. Stripper.....	5
4. Upper Die Parts.....	6
5. Lower Die Parts.....	7
6. Alignment Of Shear Blade, Anvil (A) and (B).....	8
7. Guide Plates, Feed Plate.....	9
8. Terminal Feed Pitch.....	10
9. Pressure Pad Adjustment.....	11
10. Terminal Feed Position.....	11
11. Additional Information.....	12
12. Crimp Height.....	14
13. CMK-R Parts List.....	15
14. CMK-R Exploded Diagram.....	16
15. Preventive maintenance.....	17
16. Crimping specifications.....	18

1. APPLICATOR RAM SLIDE

1-1 SLIDE ASSEMBLY

The conductor dial (108) and the insulation dial (111) are fixed by the shank (112). To remove the two disks you must first loosen the 4mm grub screw positioned in the main body of the slide, now by loosening the shank you can remove both wire disks. Positioned in the rear of the slide is the cam (119), there are two different cams available for this applicator, the first we call an upstroke cam, with this cam fitted the terminal is present over the anvil when the press is at top dead centre, this type of cam is commonly used when the applicator is located in a bench press. The other is called a downstroke cam, this operates in the opposite manner, which means the terminal feeds forward as the press travels to bottom dead centre, this type of cam is commonly used when the applicator is located in a fully automatic machine.

1-2 TROUBLE SHOOTING

The dials are difficult to turn!

1. Dismantle slide assembly as described above and check for any foreign bodies.
2. Ensure 3mm grub screw located in the insulation dial is not excessively tightened.
3. Check condition of the positioning Pin (109).

The dials turn freely but do not locate in position correctly!

1. Check the condition of the positioning spring (110) and the positioning pin (109), The Spring may be broken.
2. Ensure 3mm-grub screw located in the insulation dial is adjusted correctly.

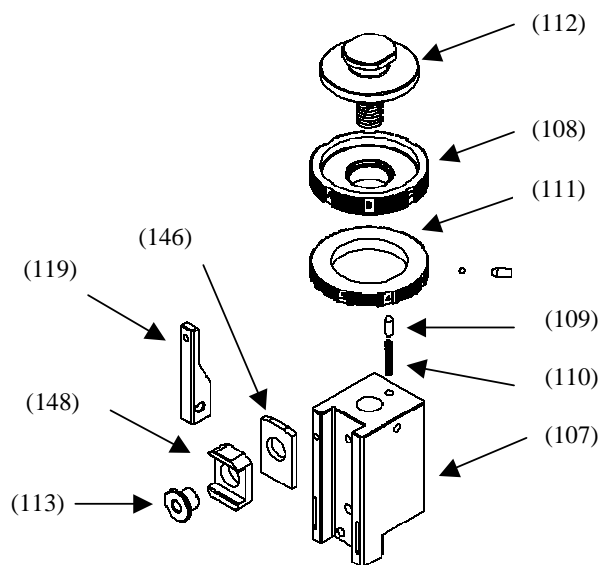

No.	DESCRIPTION
107	Ram
108	Conductor dial
109	Positioning pin
110	Positioning spring
111	Insulation dial
112	Shank
113	Block ring
119	Cam
146	Conductor spacer
148	Insulation spacer

2. SHEAR BLADE

2-1 ASSEMBLING THE SHEAR BLADE

Place spacer (149) onto the rear of the ram, making sure that the chamfered edge is facing in, and the etched part number is facing out. Place shear blade (150) into position and secure with 2 x M4 hexagon screws.

Note: Make sure that the M4 screws holding the blade and spacer DO NOT protrude through to the front of the ram, This will result in the punches not being able to float freely, and almost certainly cause punch damage.

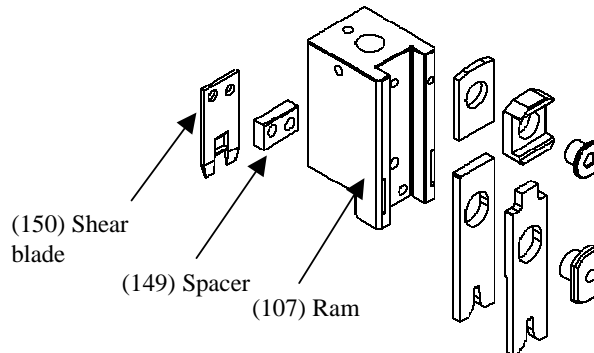

3. TERMINAL STRIPPER

3.1 PURPOSE

After the terminal has been successfully crimped on the wire, the terminal may adhere to the punches, the stripper assumes the role of removing the terminal from the punches.

3.2 ASSEMBLY

Firstly, attach the stripper (155) to the stripper bracket (142) using 2 x M4 screws, next attach the bracket (142) to the slot on the side of the main casting using 1 x M6 screw. The stripper is usually positioned between the Conductor punch and the Insulation punch, ensuring there is no contact with either part.

Depending on the kind of terminal, the stripper may be fitted to the rear of the conductor punch.

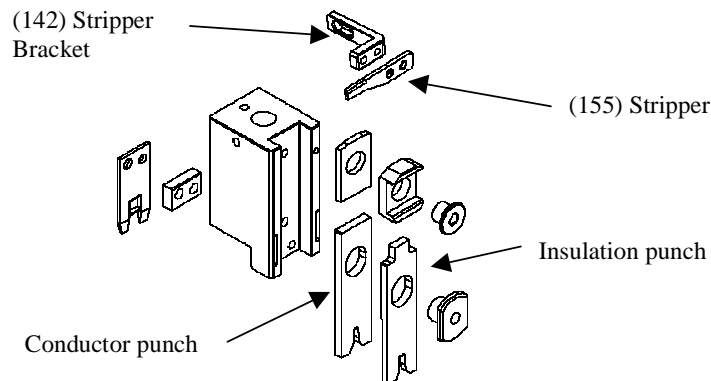

4. UPPER DIE PARTS

4-1 ASSEMBLING UPPER DIE PARTS

To ensure the upper die parts are assembled in the correct orientation the engraved part numbers must always be facing outwards.

The parts must be fitted in the correct order as detailed below:

1. Conductor spacer (146)
2. Insulation spacer (148)
3. Block ring (113)

After you have fitted these parts tighten them down with a 5mm-hexagon screw and check that they are not clamped and do move up and down freely.

4. Conductor punch (144)
5. Insulation punch (145)
6. A Spacer & wire spring are sometimes fitted between the two punches.
7. Punch Spacer (147)

After you have fitted these parts, tighten down with a 6mm-hexagon screw and again check that they are not clamped and punches do move up and down freely.

4-2 TROUBLE SHOOTING

The punches or spacers do not move freely!

1. Dismantle and check for any foreign bodies.
2. Check the sides of the punches for wear / damage or burrs.
3. Check the parts that are fitted, against the relevant die construction sheet.

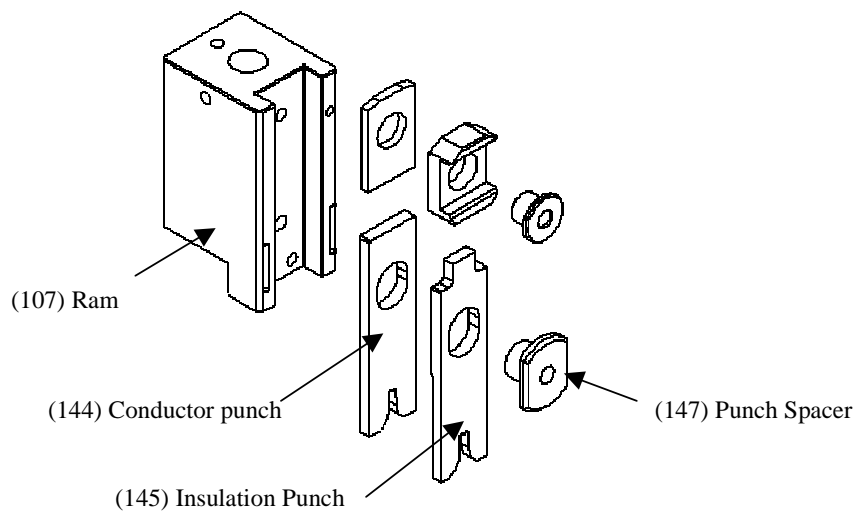

5. LOWER DIE PARTS

5-1 ASSEMBLING LOWER DIE PARTS

To ensure the lower die parts are assembled in the correct orientation the engraved part numbers must always be facing outwards.

The parts must be fitted in the correct order as detailed below:

1. Shear blade anvil (A)
2. Shear blade anvil (B)
3. Conductor anvil
4. Insulation anvil

When all the above are in place, using 2 x 5mm hexagon screws gently tighten the die parts into position.

IMPORTANT

When these parts are positioned it is essential that they are knocked down flat against the Die plate, preferably using a piece of soft metal (brass) to avoid damaging the anvil parts.

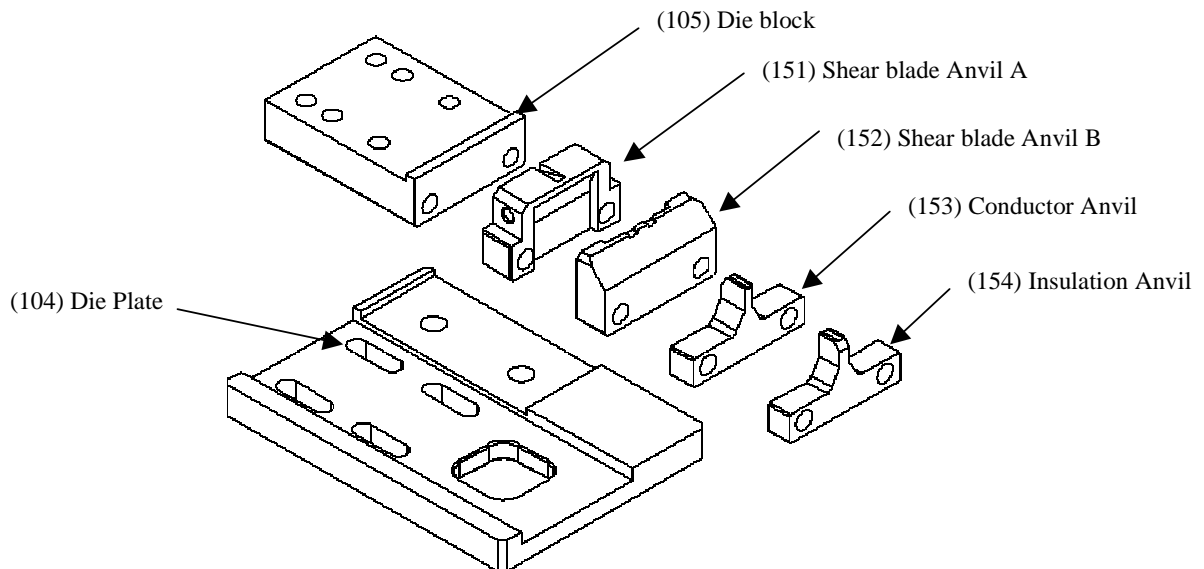

6. SHEAR BLADE

6-1 POSITIONING OF THE SHEAR BLADE

The Die block is correctly located when the Shear blade passes through the 2 Shear blade anvils freely without touching either side. To set this position correctly, follow the procedure below.

Remove the applicator from the Press and loosen the 4 x 5mm hexagon screws that attach the Die block to the Die Plate.

Bring the Ram down slowly to align the Shear Blade, with the slot in the Shear blade Anvil. When the Shear blade passes through the slot in the Shear blade anvil freely, carefully re-tighten the screws.

To ensure that you have set this part correctly you can mark both sides of the Shear blade with a pen, then slowly move the Ram up and down. If the Shear blade is positioned correctly the ink will still be present on the Blade, if the ink has been removed this indicates that the setting is incorrect.

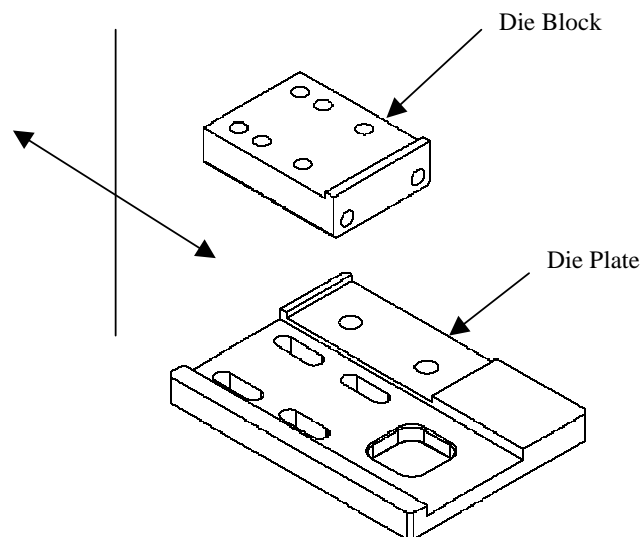
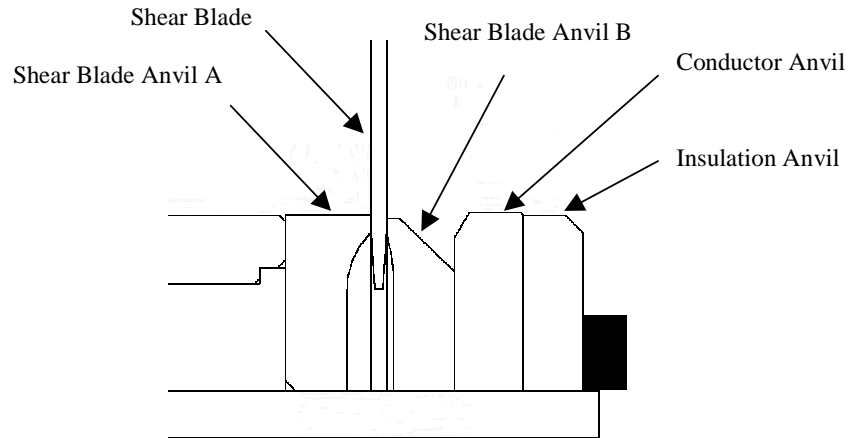

7. GUIDE PLATE

7-1 POSITIONING OF THE GUIDE PLATES

To ensure the correct alignment of the Guide Plates, firstly mount the Feed Plate onto the Die Block and secure tightly using 2 x 5mm hexagon screws. Next fit the Anvil parts as described in section 5.

Now you can fit the 2 guide plates using 4 x 4mm hexagon screws (do not tighten). Take a strip of the terminals that are compatible with the die set in the applicator and align the strip with the centre of the anvil parts ensuring that everything is parallel (see below), now you can carefully tighten the 4 x 4mm hexagon screws.

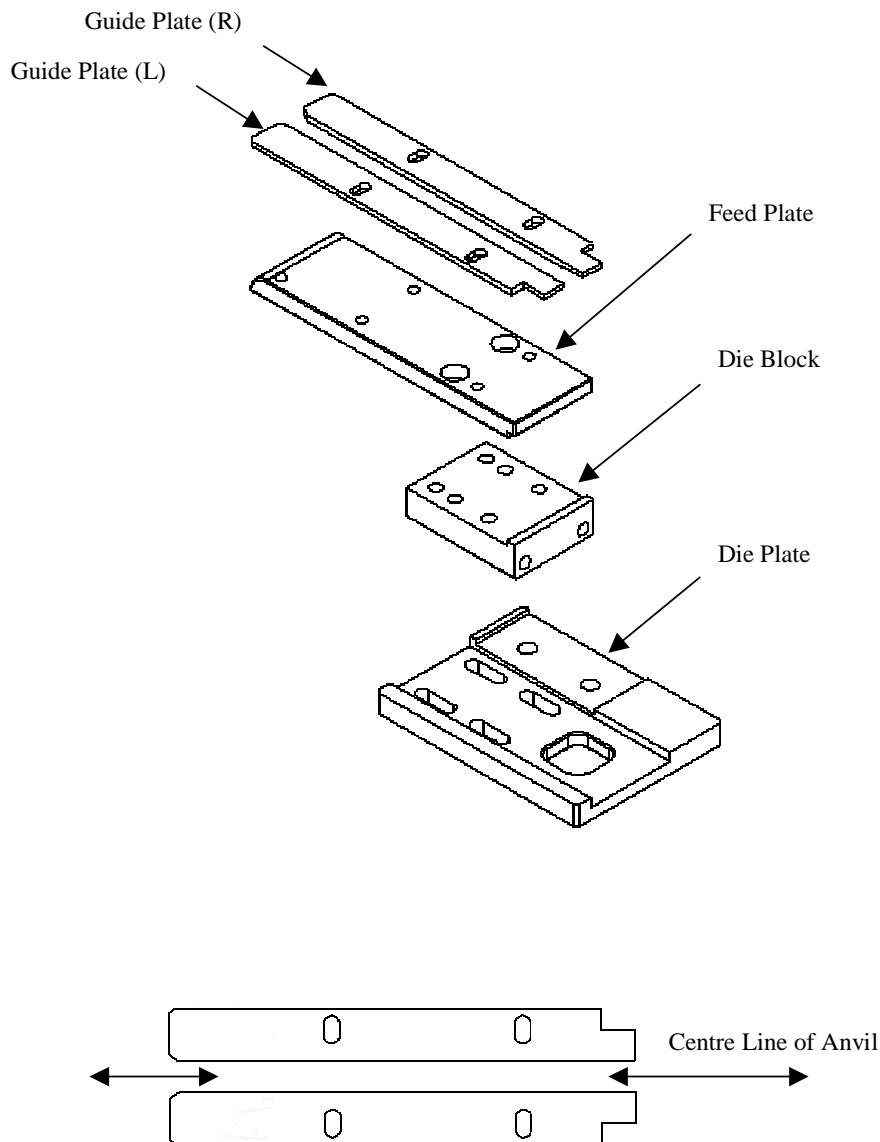

8. TERMINAL FEED PITCH

8-1 When you receive the applicator the pitch will be factory set, however if you do need to make an adjustment, please ensure that the press is switched off and the applicator is removed from the Press.

Note: The function of this nut is to achieve the correct pitch of the feed finger as shown in 8-3 (not to set the final position over the Anvil).

8-2 The pitch of the Feed Finger is adjusted by loosening the Stroke adjustment bearing nut (117) and sliding it either up, to make the stroke longer, or down, to shorten the stroke.

After you make this adjustment you will have to adjust the terminal position as described in section 10.

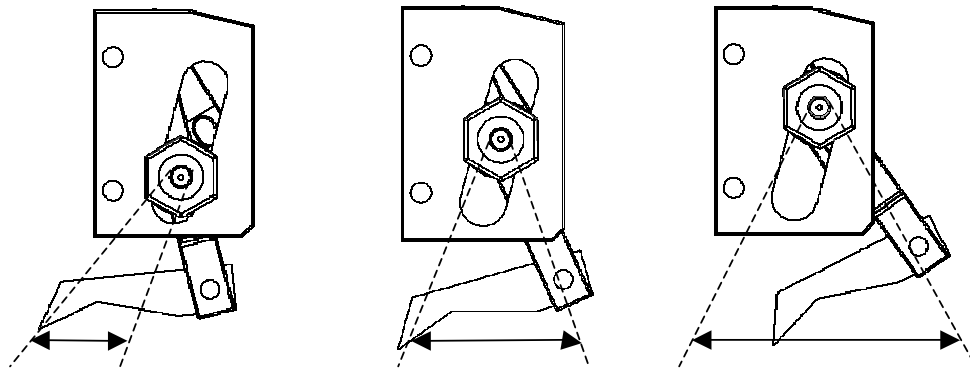

8-3 When adjusting the pitch always try to feed the terminal on the Insulation bucket as shown in the item 2 below, if this cannot be achieved then using the Conductor bucket is acceptable.



Recommended

9. PRESSURE PAD

9-1 The purpose of the Pressure pad is to insure that the Terminal stays in the correct position over the anvil when the Feed finger is moving backwards, the pressure on the terminal can be adjusted by either tightening or loosening the 2 x M5 adjustment screws as shown below.

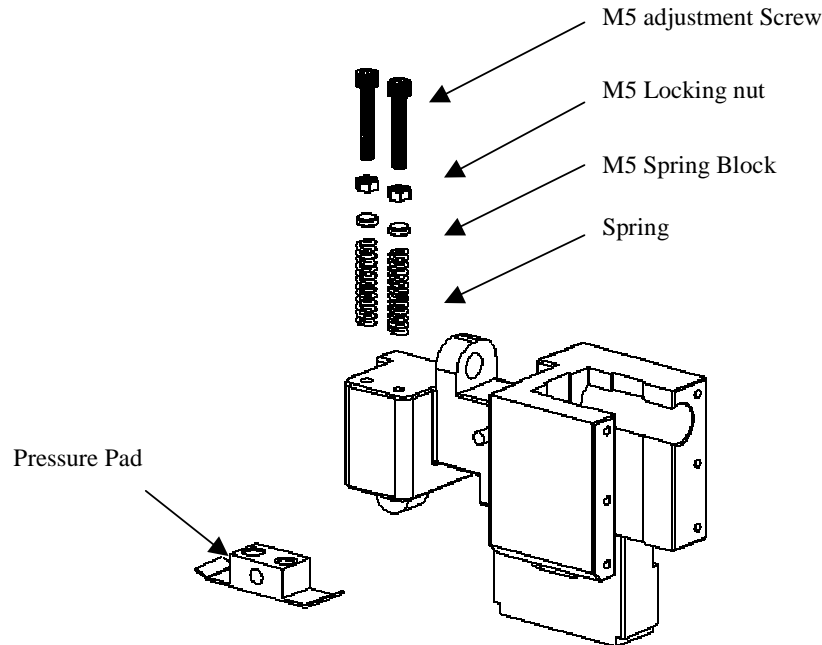

10. Terminal Feed Position

10-1 When you receive the applicator the feed will be factory set, however if you do need to make an adjustment, please ensure that the press is switched off and the applicator is removed from the Press.

Note: The function of this adjustment is to ensure that the terminal is in the correct position when crimped. See section 16.

10-2 To adjust the position of the Feed finger loosen the M5 screw in the lever block (124), then carefully loosen the Ring nut (125). Once these 2 parts have been loosened you can adjust the position of the Feed finger by rotating the Adjusting bolt (123), clockwise to take the terminal forward and anti-clockwise to bring the Terminal back. When you have assumed the correct position carefully tighten the Ring nut (125) then the M5 screw.

Now you can place the applicator back into the press and carefully rotate the Press by manual operation to see if the correct position has been achieved (See section 15). If the crimped terminal is not correct then repeat this process.

10-3 The terminal position will vary if the Pitch screw is adjusted (section 8). Please see the following page for the exploded view of this section.

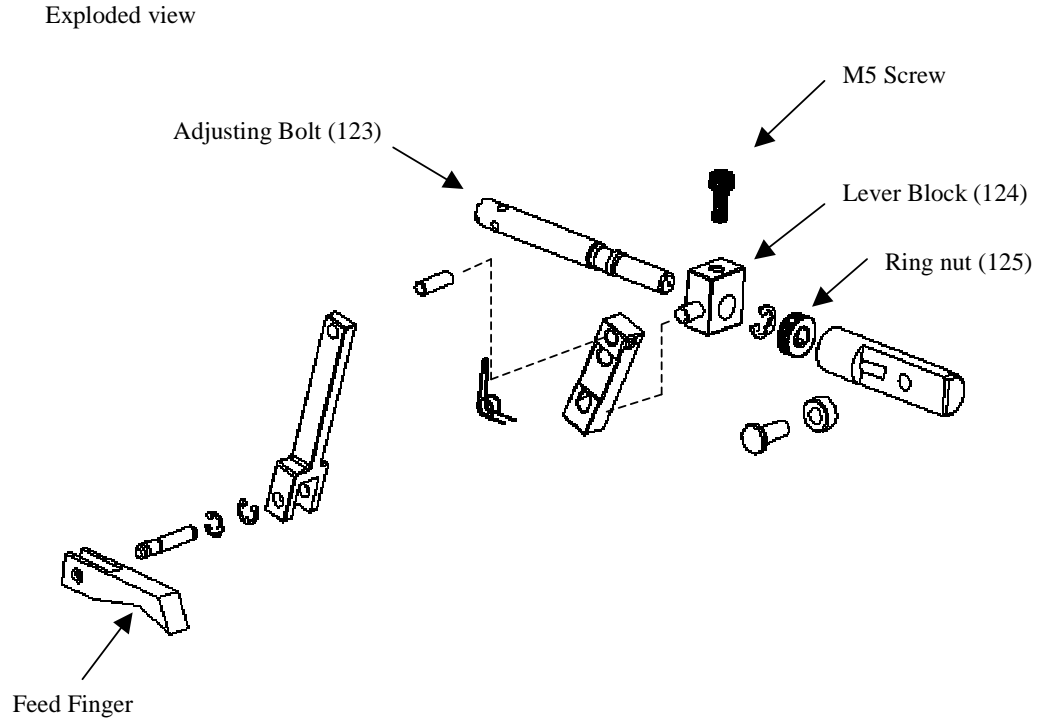

11. ADDITIONAL INFORMATION

11-1 Terminal Holder

Depending on which terminal you are processing, a Terminal holder is sometimes fitted to the Shear blade Anvil (A). The purpose of this part is to stop the terminal from lifting up with the Shear blade prior to being positioned over the Anvil.

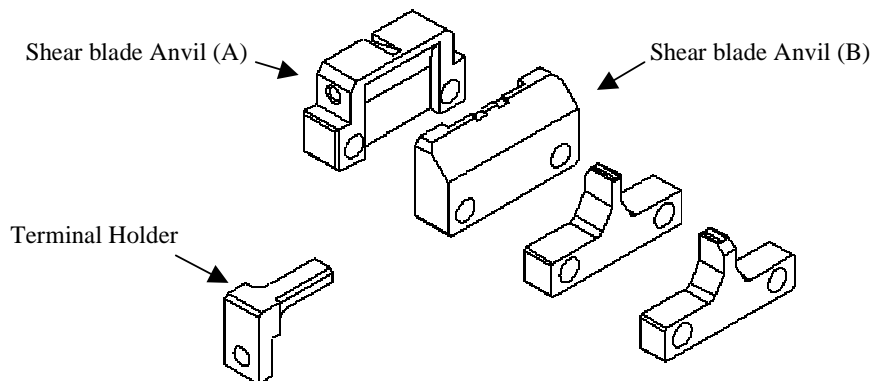

11-2 Cam Roller and Cam Roller shaft

The Cam roller's function is to move along the Cam which in turn will move the Feed finger into position, therefore, if there is any wear in this part or this part becomes damaged then it will result in the terminal being positioned incorrectly.

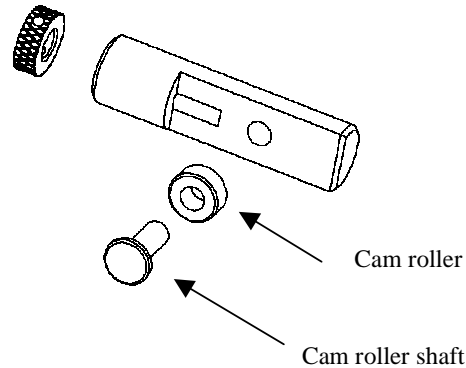

11-3 Springs

- Feed Finger Spring – The function of the Feed Finger Spring is to keep downward pressure on the feed finger to ensure consistent feeding of the Terminal.
- Return Spring – The function of the Return Spring is to ensure that the Feed finger pitches correctly every time, if this spring becomes stretched then inconsistent feeding may occur.
- Pressure Spring – The function of this spring is to keep constant pressure onto the terminal strip if this part is worn or damaged then the crimping will become inconsistent.

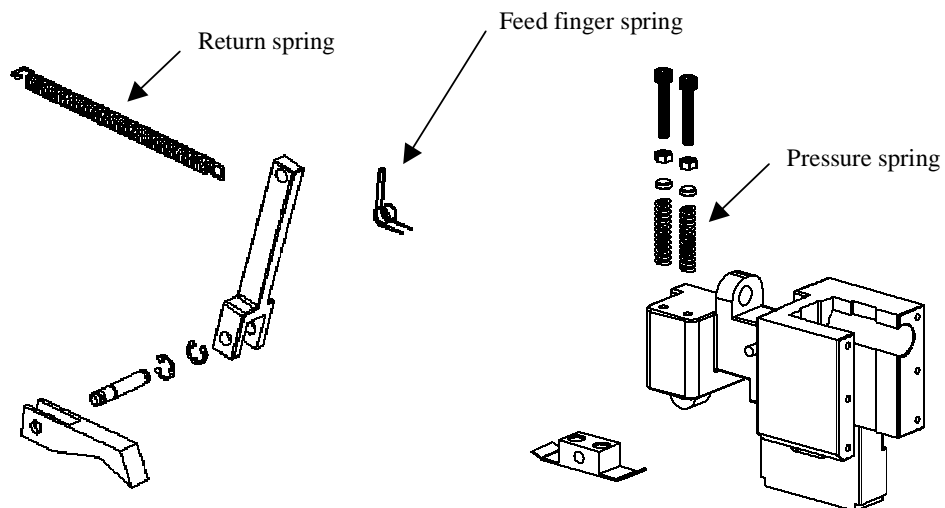

12. CRIMP HEIGHT

12-1 The 2 dials on the top of the Ram are used to adjust the conductor and Insulation crimp heights.

NOTE: The numbers and letters around these dials should **not** be used as a reference for a correct crimp, as this will vary depending on the shut height of the press the applicator is used in.

If for any reason you cannot achieve the correct crimp height, please contact our Technical services department.

12-2 Conductor crimp height

The top dial, which has the letters from A-H around it, is for adjusting the Conductor crimp height. To adjust the crimp height of the conductor, carefully rotate this dial, the lower the letter (A) the harder the crimp.

When making any adjustment it is recommended that you start with the higher letter (H) to avoid any damaged being caused by over crimping.

To ensure that you have the correct crimp height, there is a silver label fixed to the side of the applicator, this will have all the crimp heights, for the different gauge wires used with that terminal on it.

The steps between each dial setting are 0.05mm increments.

For information regarding how to measure the crimp heights please see section 16.

12-3 Insulation crimp height

The Lower dial, which has the numbers from 1-8 around it, is for adjusting the Insulation crimp height. To adjust the crimp height of the Insulation, carefully rotate this dial, the lower the number (1) the harder the crimp.

When making any adjustment it is recommended that you start with the higher number (8) to avoid any damaged being caused by over crimping.

The steps between each dial setting are 0.10mm increments.

For information regarding how to ensure that you are using the correct setting please see section 16.

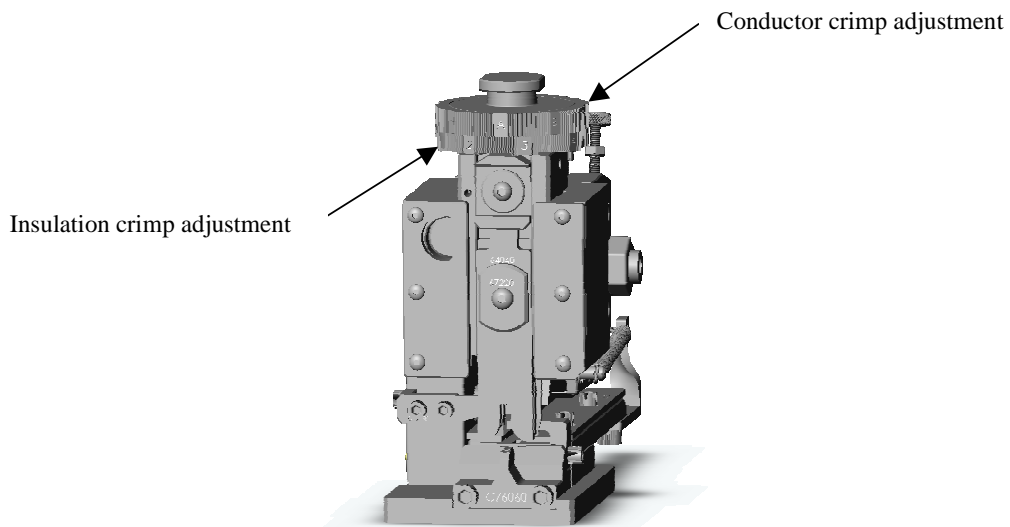

13. Parts list for the applicator CMK-R

No.	Part Name	Part No.	No.	Part Name	Part No.
101	Body	4007-2001	133	Spring anchor	4007-4011
102	Plate (L)	4007-4002	133A	Return spring	MA01-349
103	Plate (R)	4007-4003	134	Pressure pad	4007-4012
104	Die plate	4007-3004	135	Pressure pad block	4007-4013
105	Die block	4007-4005	136	Pressure pad pin	MA01-472
106	Feed plate	4007-4006	137	Release lever	4007-4014
107	Ram	4007-4007	138	Release lever pin	MA01-474
108	Conductor dial	4006-4008	139	Hook	4007-4015
109	Positioning pin	MA01-213	140	Hook pin	MA01-476
110	Positioning spring	MA01-214	141	Spring block	4007-4016
111	Insulation dial	4006-4009	142	Stripper bracket	4007-4017
112	Shank	4006-4010	143	Identification plate	4007-4018
113	Block ring	MA01-225			
114	Stroke adjustment plate	4007-4008	144	Conductor punch	
115	Stroke adjustment shaft	MA01-331	145	Insulation punch	
116	Stroke adjustment bearing	MA01-332	146	Conductor spacer	
117	Stroke adjustment bearing nut	MA01-333	147	Punch spacer	
118	Stroke adjustment screw	MA01-334	148	Insulation spacer	
119	Cam	4007-4009	149	Shear blade spacer	
120	Cam roller	MA01-308A	150	Shear blade	
121	Cam roller shaft	MA01-337A	151	Shear blade anvil (A)	
122	Feed shaft	MA01-338	152	Shear blade anvil (B)	
123	Adjustment bolt	MA01-339	153	Conductor anvil	
124	Lever block	MA01-340	154	Insulation anvil	
125	Ring nut	MA01-341	155	Stripper	
126	Feed lever (A)	MA01-342M	156	Terminal holder	
127	Feed lever support pin	MA01-343	157	Guide plate (R)	
128	Feed lever pin	MA01-344	158	Guide plate (L)	
129	Feed lever (B)	4007-4010M			
130	Feed finger	MA01-346			
131	Feed finger pin	MA01-347			
132	Feed finger Spring	MA01-348			

14. CMK-R Applicator exploded view

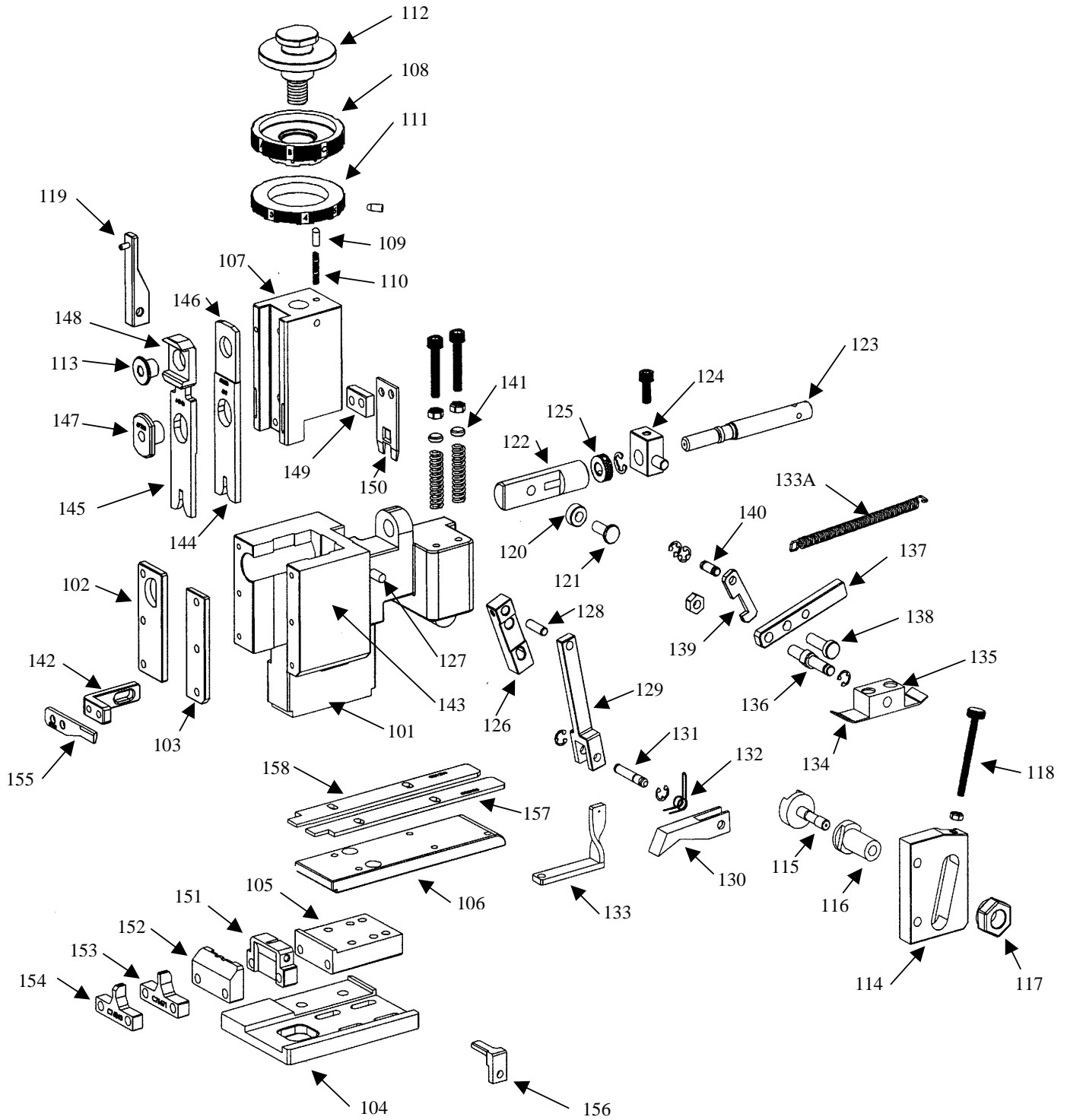

15. Preventive maintenance

Quality Statement

The quality of a finished crimp is dependent on the use of the manufacturers specified application tooling that has been cleaned and maintained in accordance with the following schedule.

Daily Care

1.1 Turn off the crimping press and isolate from the electricity supply. Remove the safety covers from the crimping press.

1.2 Clean all wire and terminal scrap from the tooling with the aid of a small paint brush.



Caution

The use of a pneumatic airline to clean the tooling should be avoided. Any debris on the tool will be blown away under great force and could either cause injury to persons nearby or be forced into moving parts of the tooling.

1.3 Visually check the crimping dies, shear section and stripper blade for evidence of wear or damage. If any parts are damaged, please contact JST to order replacement parts.

1.4 Check that there is a thin film of grease on the bearing surface of the ram, if necessary apply general-purpose grease to restore the lubrication. Do not over grease the ram, because the excess grease will either drip onto the tooling or will attract debris.

1.5 Check that the dial settings are aligned correctly over the crimping punches and that they are correctly set to the pre-determined reference position.

1.6 Check that the safety covers are in a good serviceable condition and replace on the tooling. Clean the polycarbonate safety cover with a general-purpose aerosol spray cleaner to restore good visibility.

Weekly care, or when removing the applicator from the press for storage.

In addition to the daily checks, the following maintenance should also be carried out on the tooling.

2.1 Remove the crimping punches from the ram (part numbers are affixed 63*** or 64***), please note the sequence of dis-assembly so that the parts can be replaced in the correct order. Refer to the Dies Construction Sheet supplied with the tooling for the assembly order.

2.2 Hold each crimping punch in a vice and with the aid of a piece of waste cloth apply a small amount of a good quality metal polish into the crimp form of the punch.

2.3 Using a sawing motion, polish the form until a brilliant mirror-like finish is restored.

2.4 Replace the crimping punches in the ram ensuring that the punches are free to move in a lateral axis when the retaining screw is fully tightened.

Continued overleaf

- 2.5 Remove the applicator from the crimping press (check the press operation manual for instructions if you are unsure of how to remove the applicator from the press.)
- 2.6 Check the security of the fastenings. If any part is loose, tighten with the appropriate hexagon key or spanner supplied with the crimping press.
- 2.7 Remove the ram from the main body of the applicator and clean off all the old grease from the ram, feed cam and the mating surface of the applicator.



Caution

If an aerosol degreaser is used to clean the tooling, ensure that all traces of the solvent are removed prior to reassembly.

- 2.8 Apply a thin smear of general-purpose grease to the bearing surfaces of the ram, feed cam and cam-roller assembly and replace in the body of the applicator.
- 2.9 Apply a few drops of light machine oil to each of the pivot points on the feed-arm mechanism.
- 2.10 Replace the applicator in the press.
- 2.11 Replace the safety covers.
- 2.12 If it is not intended to replace the applicator in the press, please ensure that the rubber collar supplied with the tooling is placed between the dials and the applicator body. This action will avoid any damage occurring to the crimping dies due to percussive shock when the crimping punches make contact with the crimping anvils.

Notes

Recommended materials for maintenance:

Recommended grease should be of the general purpose 'LM' type.

Recommended oil is general-purpose machine oil, i.e. '3-In-One™' oil

Recommended metal polish is of the paste type, i.e. 'Solvof Autosol™'

© J.S.T MFG. CO., LTD. 2002

The contents of this document are subject to revision from time to time. For the latest issue of this leaflet, please contact J.S.T.

16. Crimping specifications

CONTENTS

1.	Checks Before Crimping.....	20
2.	Stripping Wire Insulation.....	20
3.	Crimping.....	21
	3.1 Precautions regarding crimping.....	21
	3.2 Adjusting the crimp height (CH).....	22
	3.3 Adjusting the crimp height of the insulation barrel.....	23
	3.4 Tensile tests at the crimped section.....	25
4.	Correctly Crimped Conditions.....	25
	4.1 Crimped Appearance.....	25
	4.2 The crimped cross-section must be correctly finished as shown to the right.....	25
	4.3 All conductors must be crimped.....	26
	4.4 The lance must not be deformed.....	26
	4.5 The terminal tip and mating part must not be deformed.....	26
	4.6 The terminal must not be bent or deflected excessively.....	26
	4.7 The terminal barrel must be properly bell-mouthed.....	27
	4.8 The terminal must be cut at the correct position.....	27
	4.9 The wire must be crimped at the correct position.....	28
5.	Check-points for correct Crimping.....	29

Preface

Since the chain terminals and electric wires to be connected vary greatly in type and usage, it is difficult to provide instructions for all possible crimping combinations and conditions. This manual, therefore, provides one general guideline for your reference.

Please contact us if you have any questions regarding the use of special wires, the correct combinations of terminals and wires etc.

1. Checks Before Crimping

Check that all wires, terminals and dies to be used are correct.

(1) Use stranded wire or cord. (Check the wire size and the insulation colour).

(2) Refer to the applicable wires in the catalogue to determine which terminal type is necessary to match the wires to be used. (Check the model number and appearance).

(3) Determine which dies match the terminal. (Check that the dies are free from damage).

Note: Contact us first if you wish to use solid wires, solder-plated wires, wires not listed as applicable or other special wires.

2. Stripping Wire Insulation

The wire insulation strip length is determined by referring to the figure over. Set the correct length depending on the terminal used and strip the insulation with a wire stripper, taking care not to damage the wire conductors. Bundle the stripped wires in paper to protect the wire strands from bending or fraying when transported.

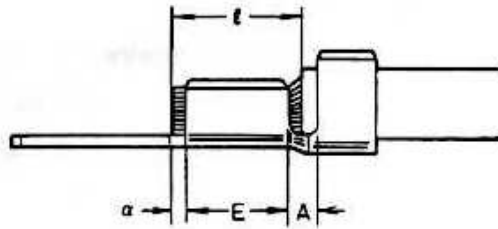

The wire insulation stripping length is determined by the following equation:

$$l = E + A/2 + a$$

The correct value of a is between 0.5 and 1.0 mm.

Precautions:

- (1) Take care to prevent damage to the wire strands, uneven strip lengths and insufficient cutting of the insulation.
- (2) Strip the shielding cable as shown below:

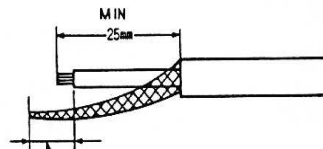

The end of the outer wire becomes uneven as the wire is twisted. Trim the wire approximately 2 to 3 mm to make it even

- (3) Do not excessively twist the conductors.

3. Crimping

3.1 Precautions regarding crimping

At first glance, crimping terminals appears to be very easy. However, crimping involves the use of a press employing 1000 kg (1 ton) of pressure. Sufficient care must be taken to prevent accidents. Please instruct beginners to work safely regardless of how much time such training requires. Always use safety guards so that an operator's fingers cannot enter the crimping die area.

Precautions:

- (1) Turn off the crimping machine whenever the Press is not in use.
- (2) Turn off the machine at the mains before adjusting the dies and feeder unit.
- (3) Do not touch the dies unless the machine is switched off.
- (4) Position the foot switch where it will not be operated by other people or falling objects.
- (5) Always concentrate on what you are doing.
- (6) Work in a stable posture.
- (7) Do not place any unnecessary objects on the die unit.
- (8) To make sure that the operating conditions are correct, manually cycle the press before going to automatic operation. After the handle is used, be sure to remove it from the crimping machine.
- (9) Always ensure that the safety guard is replaced after adjustment.

3.2 Adjusting the crimp height (CH)

After crimping, measure the crimp heights of the crimped terminal with a micrometer (Contact JST for information on suitable tools) at the centre of the wire barrel and at the centre of the insulation barrel.

Sectional view of the crimped terminal:

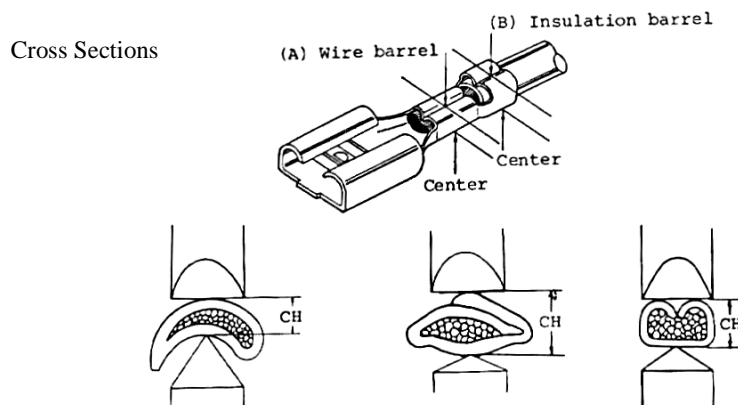

- * Set the crimp height of the wire barrel to the specified dimension.
- * Determine the crimp height of the insulation barrel in relation to the outer diameter of the wire insulation. (Refer to item 3.3)

Notes:

1. After adjusting the crimp height, use a trial sample to conduct a tensile test (refer to item 3.4) in order to examine the strength of the crimped section before going to automatic crimping operation. Occasionally examine the strength of the crimped section not only at the beginning but also during automatic operation to check for any abnormality in crimp height.
2. After the dies are replaced or the crimp height is changed and before trial crimping, rotate the manual handle to make sure that the dies do not interfere with each other. (Even when the crimp height is high, the dies may interfere with each other if the dies are incorrectly aligned. Be sure to place the dies at the correct positions).
3. When the adjustment is completed, check again that all screws are tight.

3.3 Adjusting the height of the insulation barrel

Crimping the insulation barrel is not as important as the wire crimp, but it performs an important strain-relief function.

However, excessive crimping may cause the conductor to break on the inside. Such breakage cannot be seen. Care must therefore be taken to prevent such damage.

Adjust the crimp height of the insulation section as shown in the example below.

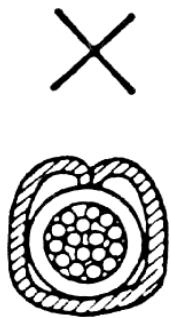

Insufficient Crimping

- The wire insulation is loose and can be moved.

Correct



- The barrel edges firmly grip the insulation.

Excessive crimping



- The barrel edges cut into the strands.

Checking for correct crimping:

Following the items described below to check that the insulation barrel is correctly crimped.

- (1) Check that the wire insulation does not slip when the wire is bent in the order (1, 2 and 3) shown the right.

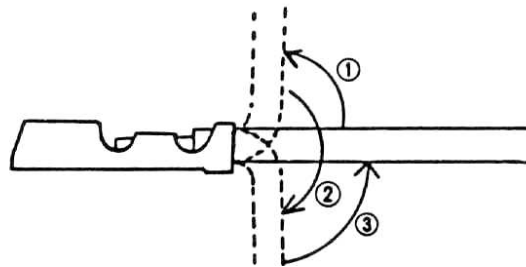

- (2) Cut off the insulation barrel at the (a) portion and cut off the wire at the (b) portion. Remove the wire insulation and check the wire conductors for damage.

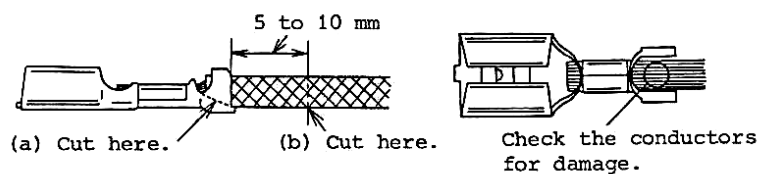

3.4 Tensile tests at the crimped section

Test a sample crimped in the normal crimping manner using a tensile tester or push-pull gauge.

A simple method of suspending a predetermined weight can also be used.

Slowly pull the sample so that it receives no abrupt shock.

Example: Tensile test with a push-pull gauge

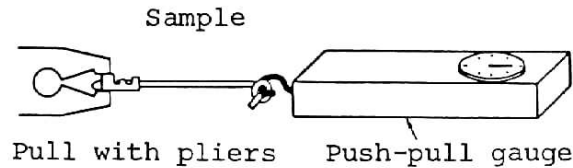

4. Correct Crimped Conditions

Crimp the terminal so that it is correctly finished as follows:

4.1 Crimped appearance:

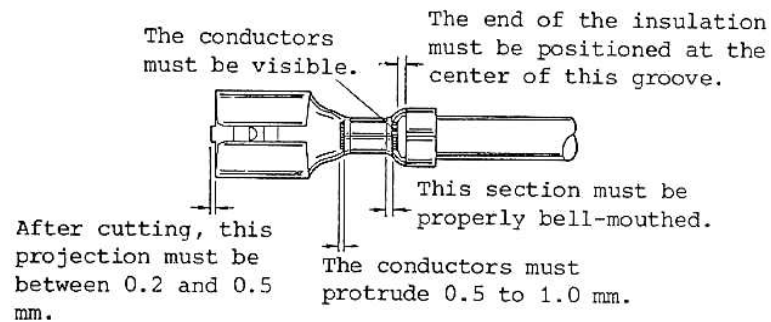

4.2 The crimped cross-section must be correctly finished as shown on the right:

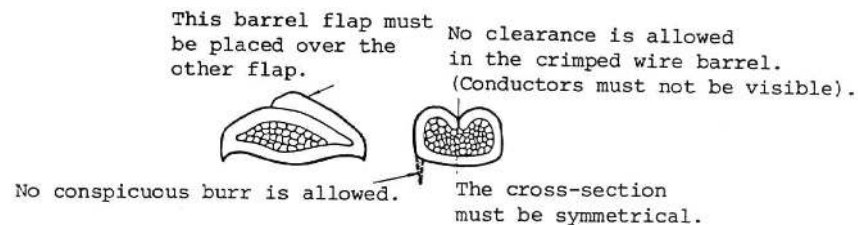

4.3 All conductors must be crimped. Uncrimped conductors are not acceptable.

Uncrimped conductors.

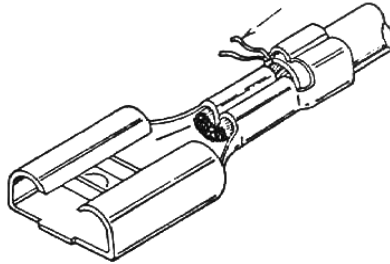

4.4 The lance must not be deformed.

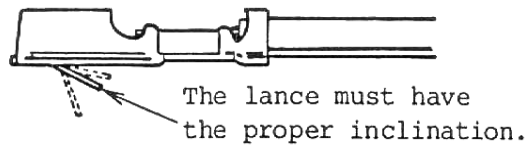

A lance that is flattened or open too much (indicated by the broken lines) is defective.

4.5 The terminal tip and mating part must not be deformed.

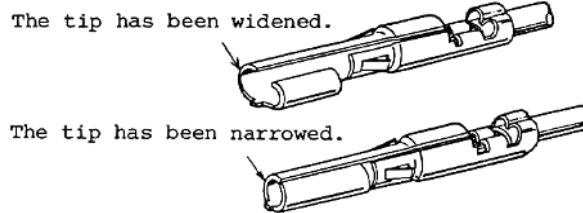

4.6 The terminal must not be bent or deflected excessively.

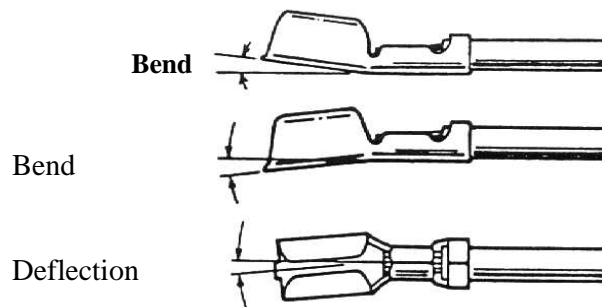

4.7 The terminal barrel must be correctly bell-mouthed.

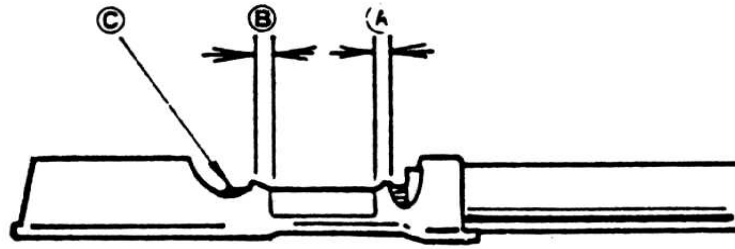

The (A) portion of the barrel must be bell-mouthed.
 The (B) portion of the barrel is not necessarily to be bell-mouthed.
 The (C) portion must be free of cracks.

4.8 The terminal must be cut at the correct position.

The projection is too long.

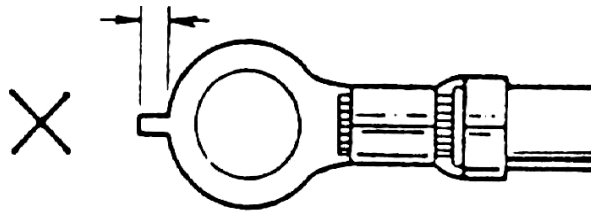

The insulation barrel of the subsequent terminal is deformed.

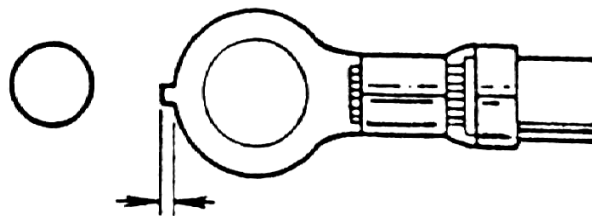

The projection should be 0.2 to 0.5 mm.

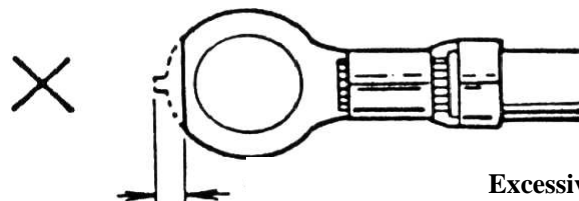

Excessive Cutting

The mating part is deformed.

4.9 The wire must be crimped at the correct position.

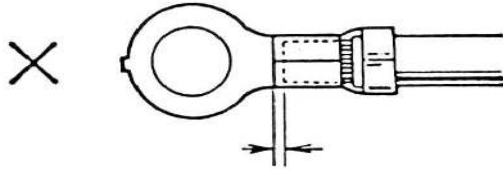

The conductors do not protrude enough. (The wire easily comes off due to incomplete crimping).

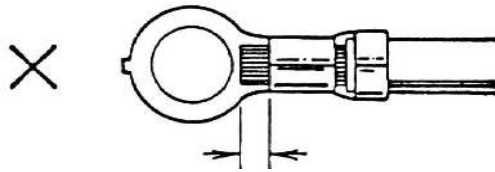

The conductors protrude excessively. (The conductors interfere with the tightening nut, preventing the terminal from being installed).

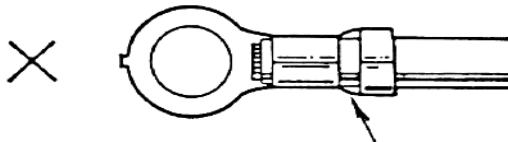

The wire insulation is crimped at the wire barrel. (Poor conduction or breakage due to excessive crimping will occur).

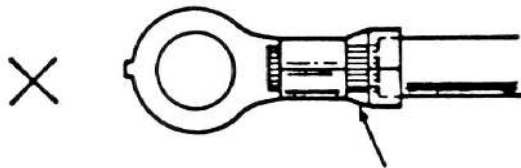

The wire insulation is not completely crimped at the insulation barrel. (The wire insulation easily comes out from the insulation barrel).

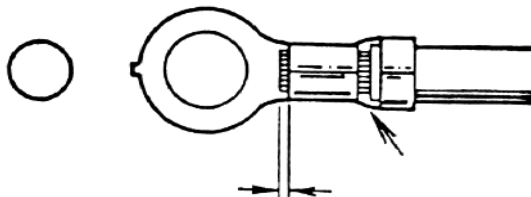

The conductors and wire insulation are visible.

The conductors must protrude 0.5 to 1.0 mm.

5. Check-points for correct Crimping

Be sure to check the following points before beginning work each day.

	Check Item
Wire barrel	Check that the crimp heights and tensile Strength is correct.
Insulation barrel	Check that the crimped shape and the crimp Heights are correct.
Appearance	<ul style="list-style-type: none"> - Check that the wire barrel is correctly bell-mouthed - Check that the wire is crimped at the correct position - Check that the crimped shape is correct - Check that all conductors are crimped - Check that the terminal lance is not deformed - Check that the mating part of the terminal is not deformed - Check that the terminal is not bent or deflected - Check that there is no conspicuous burr. - Check that the terminal is cut at the correct position

[Reference]

It is best to make up the Crimping CheckList as shown below for convenient Checking.

CRIMPING CHECK LIST

Example Form

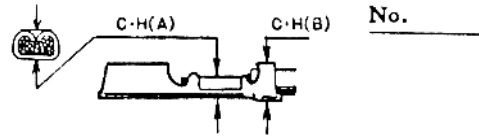

Date	Product Name	Terminal	Wire	CH(A)	CH(B)	Tensile Strength	Appearance	Worker