



Data Sheet

VMM-1627L-R

- Bone Conduction Mems Microphone: Patented surface mount vibration sensor that gathers signals transmitted through bone to achieve exceptional noise reduction. Available in 3.5 X 2.6 X 1.5 mm small package. Key applications include wearable products, such as smart wristbands, TWS headphones, Mobile phones, Medicine devices, for example heart rate detection systems.

Specifications

Parameters	Values	Units	
Sensitivity Range(1 kHz) 0 dB=1V/Pa Z Direction	-31 (Min) -29 (Typical) -26 (Max)	dB	
Operating Voltage Range	1.5 ~ 3.6	VDC	
DC output	0.6	V	
Max Current consumption	150	μA	
Signal to Noise (S/N) Ratio	73	dB (A)	
Acceleration	±4	g THD <1% @ 1KHz	
Output Impedance	300	Ω	
Air Conduction Noise Suppression (@ 1kHz)	>40	dB	
Noise Density	250 Hz 1 kHz 2 kHz	-94 -101 -101	dBV/ √Hz
Peak Frequency	5	kHz	
Environmental Compliances	RoHS/REACH	-	
Operating Temperature	-30 ~ +70	°C	
Storage Temperature	-30 ~ +85	°C	
MSL (moisture sensitivity Level)	Class 1		

Test Circuit

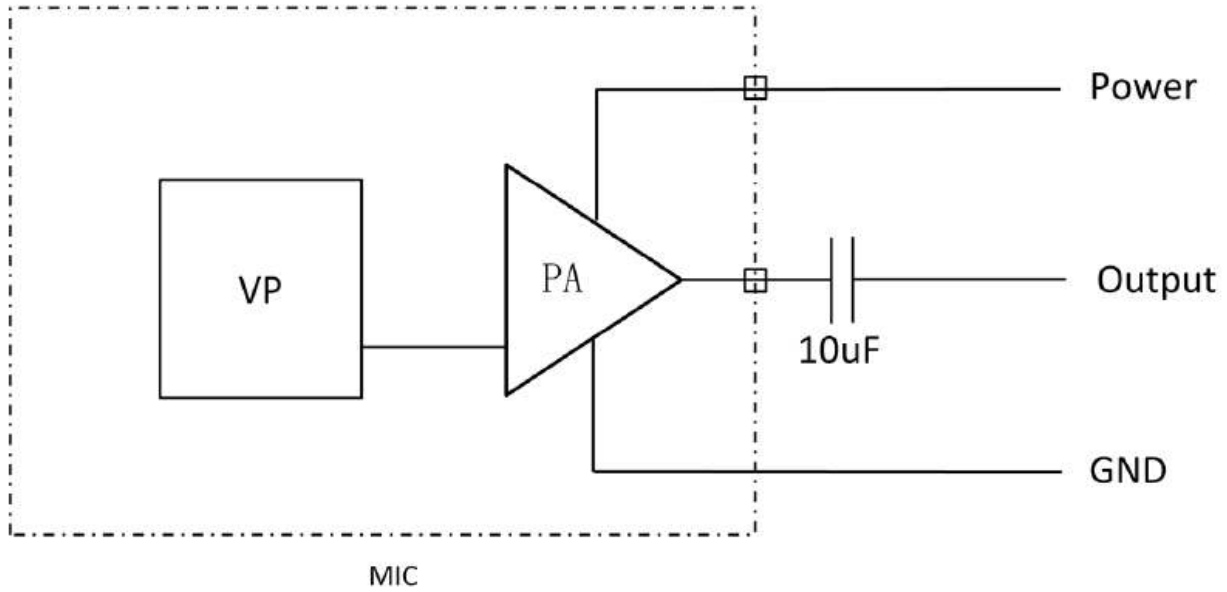

Measurement Method

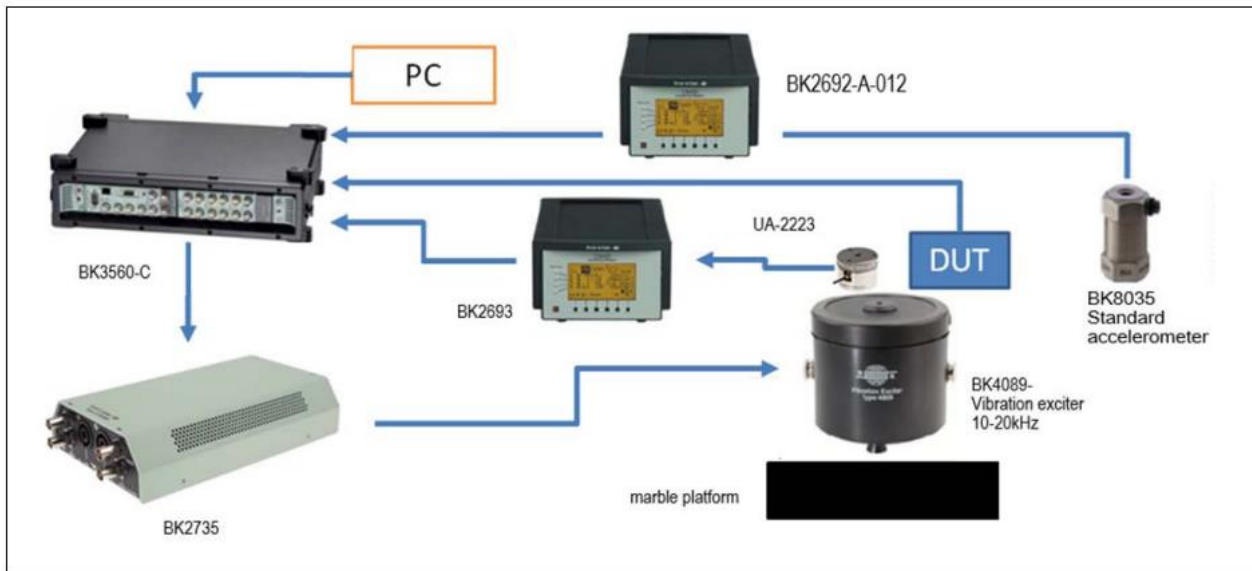

Typical Frequency Response

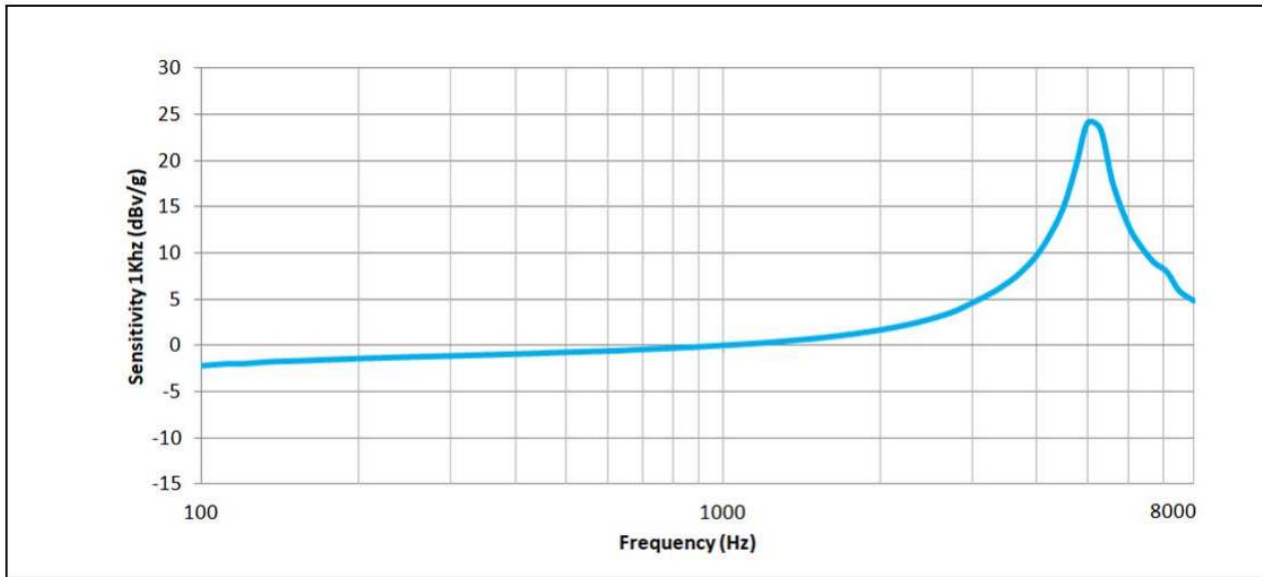

Recommended Soldering Procedure

Recommend reflow profile, solder reflow $\leq 260^{\circ}\text{C}$ (for 30s Max of peak temperature)

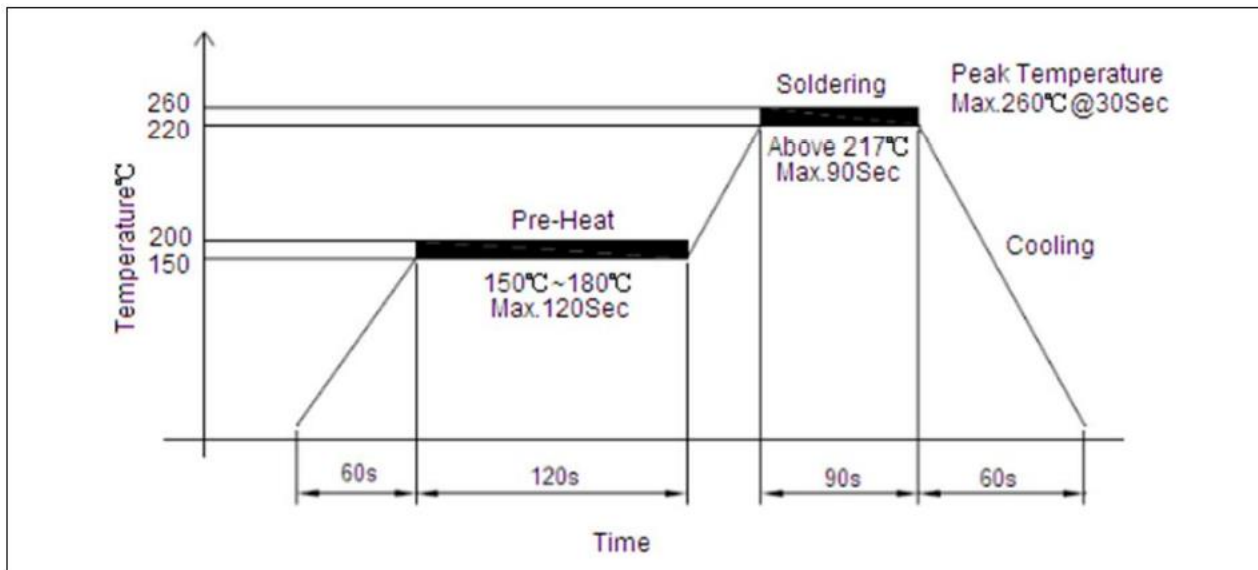

Important Notes In order to minimize device damage:

1. Times of reflow ≤ 3
2. Pressure relief hole can't be covered.
3. Pressure relief hole can't be blown by strong wind.
4. Do not wash or clean the boards after the reflow process.
5. In the process of reflux, there can be no atomizing solvent or liquid

Reliability Testing

Type of Test	Test Specifications
High Temperature Humidity Test	1000 hours at 85 °C with relative humidity at 85%
Thermal Shocking	-30 °C for 30 minutes to 125 °C for 30 minutes with 5 minutes temperature changing time
Vibration Test	30 minutes in each x, y, and z axis from 10 Hz to 55 Hz
Mechanical Shock Test	Subject samples to half sine shock pulses (3000 g \pm 15% for 0.3 ms) in each direction, total of 18 shocks
Operation Life	Subject samples to +125 °C for 168 hours with full maximum rated voltage
Drop Test	Drop from a height of 1.5 m on to marble floor 4 times on 6 surfaces.

After each test, the part shall be within ± 3 dB of specification after 2 hours of rest at standard room conditions

Dimensions

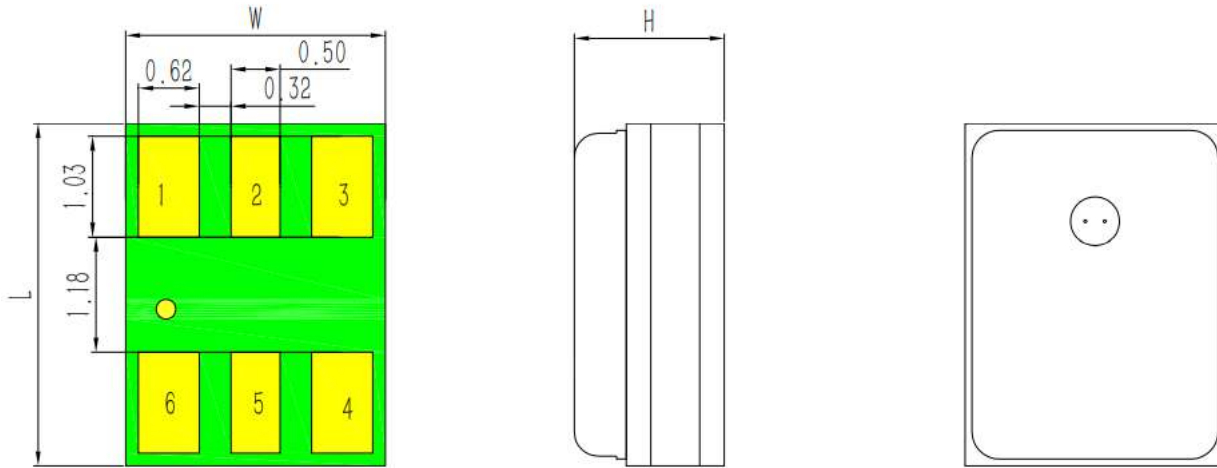

Item	Dimension	Tolerance(+/-)	Units
Length(L)	3.5	0.10	mm
Width(W)	2.65	0.10	mm
Height(H)	1.55	0.10	mm

PIN	Signal	Description
1	GND	Ground
2	GND	Ground
3	VDD	Power Suply
4	GND	Ground
5	GND	Ground
6	OUT	Output signal

Notes:

- All dimensions are in millimeter (mm).
- Tolerance ± 0.15 mm unless otherwise specified.

Suggested Land Pattern*

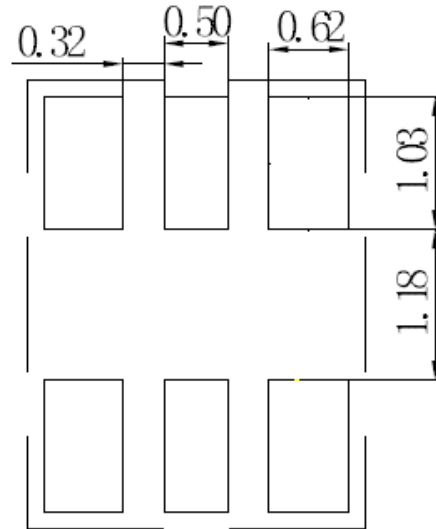
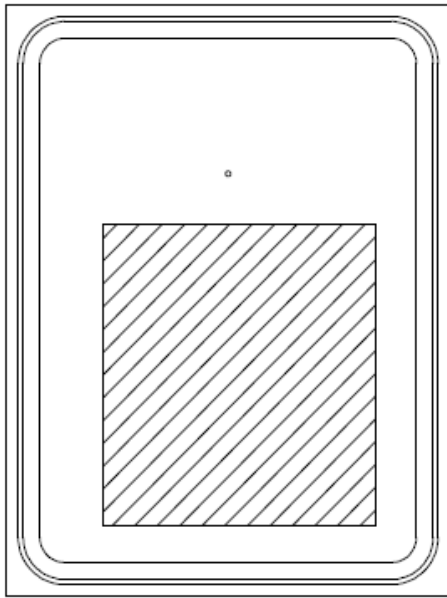

*This land pattern is advisory only and its use or adaptation is entirely voluntary. PUI Audio disclaims all liability of any kind associated with the use, application, or adaptation of this land pattern.

Packaging

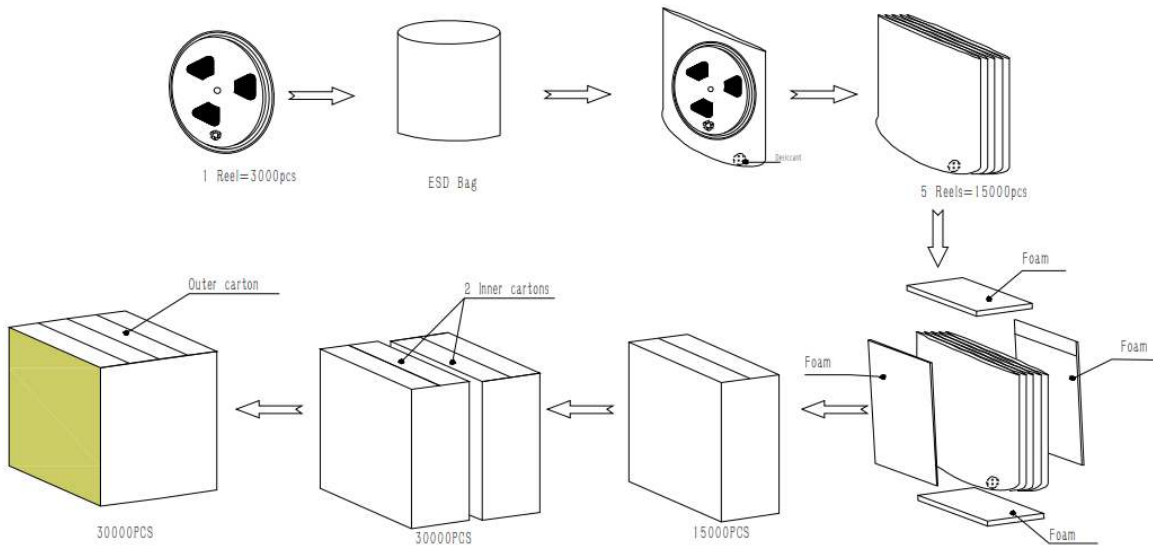
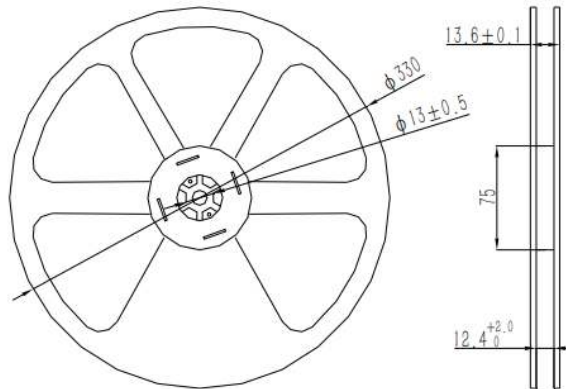
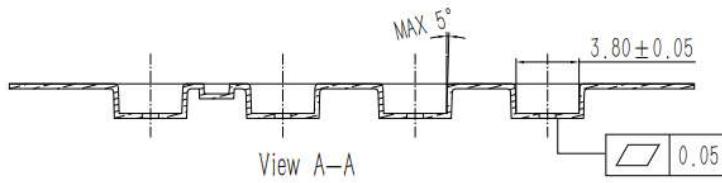
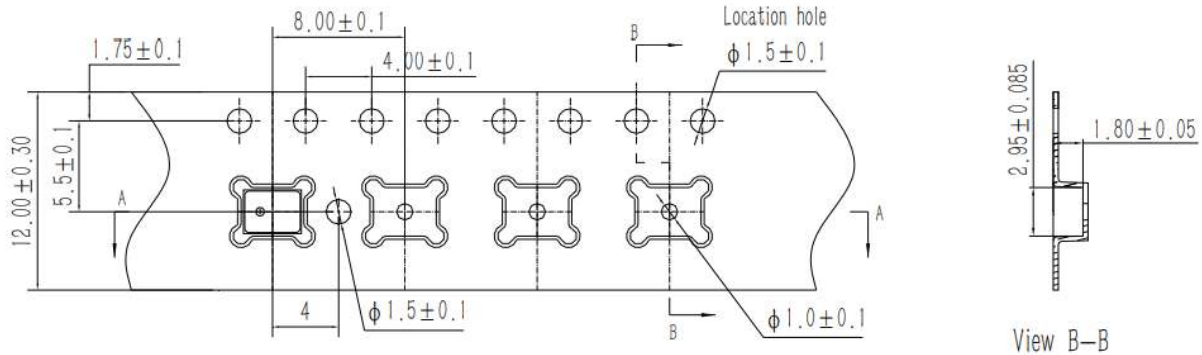

Specifications Revisions

Revision	Description	Date
A	Released from Engineering	10/24/2022

Note:

- 1. Unless otherwise specified:
 - A. All dimensions are in millimeters.
 - B. Default tolerances are $\pm 0.5\text{mm}$ and angles are $\pm 3^\circ$.
- 2. Specifications subject to change or withdrawal without notice.