

NTC ICL

Inrush current limiter radial lead NTC thermistor

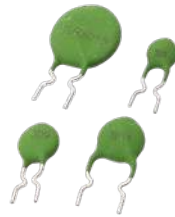

Product features

- Epoxy sealed radial lead NTC thermistor
- High rated power, low power consumption
- 5 to 30 millimeter disk type
- Resistance range 0.5 Ω to 120 Ω
- Non-linear change in resistance vs temperature

Applications

- Switched mode power supplies
- Power conversion
- Uninterruptible power supplies
- Inverter systems
- Vac and Vdc motors
- Lighting drivers
- Toroidal transformer circuits
- Supercapacitor or other capacitor pre-charging circuits
- High power industrial equipment (welders, cutting and other robotics)

Environmental compliance and general specifications



Table 1. Part numbering

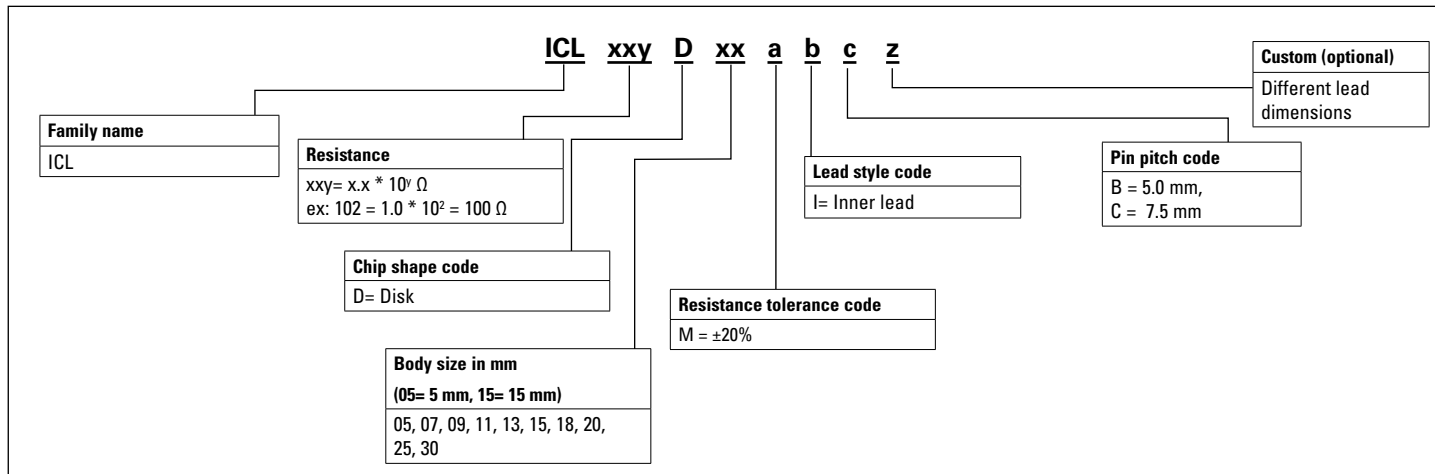

See electrical specification table for option details

Mechanical parameters- mm

I (Inner lead)

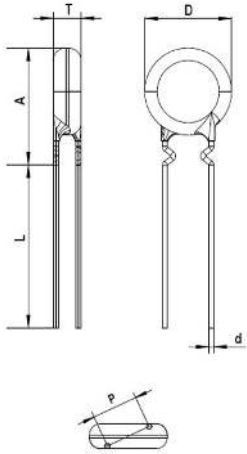

Disk size	D maximum	T maximum	P	d	A maximum	L
D05	7	5	5 ±0.5	0.6 ±0.02	12.5	3.5 ±0.5
D07	8.5	5	5 ±0.5	0.6 ±0.02	14.5	3.5 ±0.5
D09	9.5	5	5 ±0.5	0.8 ±0.02	15.5	3.5 ±0.5
D11	12	6	5 ±0.5	0.8 ±0.02	18	3.5 ±0.5
D13	13	6	7.5 ±0.8	0.8 ±0.02	19	3.5 ±0.5
D15	16	6	7.5 ±0.8	0.8 ±0.02	22	3.5 ±0.5
D18	19	7	7.5 ±0.8	1.0 ±0.02	25	3.5 ±0.5
D20	23	7	7.5 ±0.8	1.0 ±0.02	29	3.5 ±0.5
D25	28	8	7.5 ±0.8	1.0 ±0.02	34	3.5 ±0.5
D30	34	8	7.5 ±0.8	1.0 ±0.02	40	3.5 ±0.5

D05 (5 mm) to D11 (11 mm) Leads: tin plated copper clad steel covered CCS leads

D13 (13 mm) to D30 (30 mm) Leads: tin plated copper

Part marking

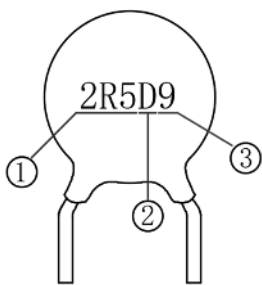

Number	Item	Code	Specification
		2R5	2.5 Ω
1	Zero Power Resistance at 25 °C	10	10 Ω
		100	100 Ω
2	Chip shape	D	Disk type
3	Size	9	9 mm

Packaging information

Part number	BULK (pcs/bag)
ICLxxxD05xxx	1000
ICLxxxD07xxx	1000
ICLxxxD09xxx	500
ICLxxxD11xxx	500
ICLxxxD13xxx	500
ICLxxxD15xxx	250
ICLxxxD18xxx	100
ICLxxxD20xxx	100
ICLxxxD25xxx	50
ICLxxxD30xxx	50

Electrical specifications

Part number	Zero power resistance @ +25°C R ₂₅ (Ω)	Resistance tolerance (Part number code)	Lead style (Part number code)	Pin pitch (Part number code)	I _{max} (A)	Beta value (25/50) (K)	CT, maximum permissible capacitance at 240 Vac (μF)	Dissipation factor (mW/°C)	Thermal time constant T (second)	Operation temperature TL-TU(°C)
ICL300D05abc	3	±20% (M)	Inner lead (I)	5.0 mm (B) 7.5 mm (C)	2	2500	70	7 ±3	20 ±6	-40 to +150
ICL400D05abc	4	±20% (M)	Inner lead (I)	5.0 mm (B) 7.5 mm (C)	2	2500	70	7 ±3	20 ±6	-40 to +150
ICL500D05abc	5	±20% (M)	Inner lead (I)	5.0 mm (B) 7.5 mm (C)	2	2550	70	7 ±3	20 ±6	-40 to +150
ICL800D05abc	8	±20% (M)	Inner lead (I)	5.0 mm (B) 7.5 mm (C)	1	2600	70	7 ±3	20 ±6	-40 to +150
ICL101D05abc	10	±20% (M)	Inner lead (I)	5.0 mm (B) 7.5 mm (C)	1	2650	70	7 ±3	20 ±6	-40 to +150
ICL121D05abc	12	±20% (M)	Inner lead (I)	5.0 mm (B) 7.5 mm (C)	1	2650	70	7 ±3	20 ±6	-40 to +150
ICL161D05abc	16	±20% (M)	Inner lead (I)	5.0 mm (B) 7.5 mm (C)	1	2700	70	7 ±3	20 ±6	-40 to +150
ICL201D05abc	20	±20% (M)	Inner lead (I)	5.0 mm (B) 7.5 mm (C)	1	2700	70	7 ±3	20 ±6	-40 to +150
ICL300D07abc	3	±20% (M)	Inner lead (I)	5.0 mm (B) 7.5 mm (C)	3	2550	120	8 ±3	30 ±9	-40 to +170
ICL400D07abc	4	±20% (M)	Inner lead (I)	5.0 mm (B) 7.5 mm (C)	3	2600	120	8 ±3	30 ±9	-40 to +170
ICL500D07abc	5	±20% (M)	Inner lead (I)	5.0 mm (B) 7.5 mm (C)	3	2600	120	8 ±3	30 ±9	-40 to +170
ICL600D07abc	6	±20% (M)	Inner lead (I)	5.0 mm (B) 7.5 mm (C)	3	2650	120	8 ±3	30 ±9	-40 to +170
ICL700D07abc	7	±20% (M)	Inner lead (I)	5.0 mm (B) 7.5 mm (C)	3	2650	120	8 ±3	30 ±9	-40 to +170
ICL800D07abc	8	±20% (M)	Inner lead (I)	5.0 mm (B) 7.5 mm (C)	2	2700	120	8 ±3	30 ±9	-40 to +170
ICL101D07abc	10	±20% (M)	Inner lead (I)	5.0 mm (B) 7.5 mm (C)	2	2700	120	8 ±3	30 ±9	-40 to +170
ICL151D07abc	15	±20% (M)	Inner lead (I)	5.0 mm (B) 7.5 mm (C)	2	2750	120	8 ±3	30 ±9	-40 to +170
ICL201D07abc	20	±20% (M)	Inner lead (I)	5.0 mm (B) 7.5 mm (C)	1.5	2800	120	8 ±3	30 ±9	-40 to +170
ICL301D07abc	30	±20% (M)	Inner lead (I)	5.0 mm (B) 7.5 mm (C)	1	2850	120	8 ±3	30 ±9	-40 to +170

a= Enter resistance tolerance code from table above (M = ±20%)

b= Enter lead style code from table above (I= Inner lead)

c= Enter pin pitch code from table above (B = 5.0 mm, C = 7.5 mm)

Electrical specifications, cont.

Part number	Zero power resistance @ +25°C R ₂₅ (Ω)	Resistance tolerance (Part number code)	Lead style (Part number code)	Pin pitch (Part number code)	I _{max} (A)	Beta value (25/50) (K)	CT, maximum permissible capacitance at 240 Vac (μF)	Dissipation factor (mW/°C)	Thermal time constant T (second)	Operation temperature TL~TU(°C)
ICL250D09abc	2.5	±20% (M)	Inner lead (I)	5.0 mm (B) 7.5 mm (C)	4	2550	180	9 ±3	40 ±12	-40 to +170
ICL300D09abc	3	±20% (M)	Inner lead (I)	5.0 mm (B) 7.5 mm (C)	4	2600	180	9 ±3	40 ±12	-40 to +170
ICL500D09abc	5	±20% (M)	Inner lead (I)	5.0 mm (B) 7.5 mm (C)	3.5	2650	180	9 ±3	40 ±12	-40 to +170
ICL600D09abc	6	±20% (M)	Inner lead (I)	5.0 mm (B) 7.5 mm (C)	3.5	2700	180	9 ±3	40 ±12	-40 to +170
ICL700D09abc	7	±20% (M)	Inner lead (I)	5.0 mm (B) 7.5 mm (C)	3	2700	180	9 ±3	40 ±12	-40 to +170
ICL800D09abc	8	±20% (M)	Inner lead (I)	5.0 mm (B) 7.5 mm (C)	2.5	2700	180	9 ±3	40 ±12	-40 to +170
ICL101D09abc	10	±20% (M)	Inner lead (I)	5.0 mm (B) 7.5 mm (C)	2.5	2750	180	9 ±3	40 ±12	-40 to +170
ICL151D09abc	15	±20% (M)	Inner lead (I)	5.0 mm (B) 7.5 mm (C)	2.5	2800	180	9 ±3	40 ±12	-40 to +170
ICL201D09abc	20	±20% (M)	Inner lead (I)	5.0 mm (B) 7.5 mm (C)	2	2850	180	9 ±3	40 ±12	-40 to +170
ICL301D09abc	30	±20% (M)	Inner lead (I)	5.0 mm (B) 7.5 mm (C)	1.5	2950	180	9 ±3	40 ±12	-40 to +170
ICL601D09abc	60	±20% (M)	Inner lead (I)	5.0 mm (B) 7.5 mm (C)	1	3150	180	9 ±3	40 ±12	-40 to +170
ICL070D11abc	0.7	±20% (M)	Inner lead (I)	5.0 mm (B) 7.5 mm (C)	6	2500	300	11 ±4	60 ±18	-40 to +170
ICL100D11abc	1	±20% (M)	Inner lead (I)	5.0 mm (B) 7.5 mm (C)	6	2500	300	11 ±4	60 ±18	-40 to +170
ICL130D11abc	1.3	±20% (M)	Inner lead (I)	5.0 mm (B) 7.5 mm (C)	6	2550	300	11 ±4	60 ±18	-40 to +170
ICL150D11abc	1.5	±20% (M)	Inner lead (I)	5.0 mm (B) 7.5 mm (C)	6	2550	300	11 ±4	60 ±18	-40 to +170
ICL250D11abc	2.5	±20% (M)	Inner lead (I)	5.0 mm (B) 7.5 mm (C)	5.5	2600	300	11 ±4	60 ±18	-40 to +170
ICL300D11abc	3	±20% (M)	Inner lead (I)	5.0 mm (B) 7.5 mm (C)	5.5	2650	300	11 ±4	60 ±18	-40 to +170
ICL400D11abc	4	±20% (M)	Inner lead (I)	5.0 mm (B) 7.5 mm (C)	4.5	2700	300	11 ±4	60 ±18	-40 to +170
ICL500D11abc	5	±20% (M)	Inner lead (I)	5.0 mm (B) 7.5 mm (C)	4.5	2700	300	11 ±4	60 ±18	-40 to +170
ICL680D11abc	6.8	±20% (M)	Inner lead (I)	5.0 mm (B) 7.5 mm (C)	3.5	2750	300	11 ±4	60 ±18	-40 to +170

a= Enter resistance tolerance code from table above (M = ±20%)

b= Enter lead style code from table above (I= Inner lead)

c= Enter pin pitch code from table above (B = 5.0 mm, C = 7.5 mm)

Electrical specifications, cont.

Part number	Zero power resistance @ +25°C R ₂₅ (Ω)	Resistance tolerance (Part number code)	Lead style (Part number code)	Pin pitch (Part number code)	I _{max} (A)	Beta value (25/50) (K)	CT, maximum permissible capacitance at 240 Vac (μF)	Dissipation factor (mW/°C)	Thermal time constant T (second)	Operation temperature TL-TU(°C)
ICL800D11abc	8	±20% (M)	Inner lead (I)	5.0 mm (B) 7.5 mm (C)	3.5	2800	300	11 ±4	60 ±18	-40 to +170
ICL101D11abc	10	±20% (M)	Inner lead (I)	5.0 mm (B) 7.5 mm (C)	3	2800	300	11 ±4	60 ±18	-40 to +170
ICL121D11abc	12	±20% (M)	Inner lead (I)	5.0 mm (B) 7.5 mm (C)	3	2850	300	11 ±4	60 ±18	-40 to +170
ICL131D11abc	13	±20% (M)	Inner lead (I)	5.0 mm (B) 7.5 mm (C)	3	2850	300	11 ±4	60 ±18	-40 to +170
ICL151D11abc	15	±20% (M)	Inner lead (I)	5.0 mm (B) 7.5 mm (C)	2.5	2850	300	11 ±4	60 ±18	-40 to +170
ICL161D11abc	16	±20% (M)	Inner lead (I)	5.0 mm (B) 7.5 mm (C)	2.5	2900	300	11 ±4	60 ±18	-40 to +170
ICL201D11abc	20	±20% (M)	Inner lead (I)	5.0 mm (B) 7.5 mm (C)	2.5	2950	300	11 ±4	60 ±18	-40 to +170
ICL221D11abc	22	±20% (M)	Inner lead (I)	5.0 mm (B) 7.5 mm (C)	2.5	2950	300	11 ±4	60 ±18	-40 to +170
ICL251D11abc	25	±20% (M)	Inner lead (I)	5.0 mm (B) 7.5 mm (C)	2	3000	300	11 ±4	60 ±18	-40 to +170
ICL301D11abc	30	±20% (M)	Inner lead (I)	5.0 mm (B) 7.5 mm (C)	2	3100	300	11 ±4	60 ±18	-40 to +170
ICL471D11abc	47	±20% (M)	Inner lead (I)	5.0 mm (B) 7.5 mm (C)	2	3150	300	11 ±4	60 ±18	-40 to +170
ICL501D11abc	50	±20% (M)	Inner lead (I)	5.0 mm (B) 7.5 mm (C)	2	3200	300	11 ±4	60 ±18	-40 to +170
ICL801D11abc	80	±20% (M)	Inner lead (I)	5.0 mm (B) 7.5 mm (C)	1.5	3300	300	11 ±4	60 ±18	-40 to +170
ICL102D11abc	100	±20% (M)	Inner lead (I)	5.0 mm (B) 7.5 mm (C)	1	3300	300	11 ±4	60 ±18	-40 to +170
ICL122D11abc	120	±20% (M)	Inner lead (I)	5.0 mm (B) 7.5 mm (C)	1	3400	300	11 ±4	60 ±18	-40 to +170
ICL070D13abc	0.7	±20% (M)	Inner lead (I)	5.0 mm (B) 7.5 mm (C)	7	2500	350	12 ±4	70 ±21	-40 to +200
ICL100D13abc	1	±20% (M)	Inner lead (I)	5.0 mm (B) 7.5 mm (C)	7	2550	350	12 ±4	70 ±21	-40 to +200
ICL130D13abc	1.3	±20% (M)	Inner lead (I)	5.0 mm (B) 7.5 mm (C)	7	2550	350	12 ±4	70 ±21	-40 to +200
ICL150D13abc	1.5	±20% (M)	Inner lead (I)	5.0 mm (B) 7.5 mm (C)	7	2550	350	12 ±4	70 ±21	-40 to +200
ICL250D13abc	2.5	±20% (M)	Inner lead (I)	5.0 mm (B) 7.5 mm (C)	6	2650	350	12 ±4	70 ±21	-40 to +200

a= Enter resistance tolerance code from table above (M = ±20%)

b= Enter lead style code from table above (I= Inner lead)

c= Enter pin pitch code from table above (B = 5.0 mm, C = 7.5 mm)

Electrical specifications, cont.

Part number	Zero power resistance @ +25°C R ₂₅ (Ω)	Resistance tolerance (Part number code)	Lead style (Part number code)	Pin pitch (Part number code)	I _{max} (A)	Beta value (25/50) (K)	CT, maximum permissible capacitance at 240 Vac (μF)	Dissipation factor (mW/°C)	Thermal time constant T (second)	Operation temperature TL-TU(°C)
ICL400D13abc	4	±20% (M)	Inner lead (I)	5.0 mm (B) 7.5 mm (C)	5	2700	350	12 ±4	70 ±21	-40 to +200
ICL470D13abc	4.7	±20% (M)	Inner lead (I)	5.0 mm (B) 7.5 mm (C)	4.5	2700	350	12 ±4	70 ±21	-40 to +200
ICL500D13abc	5	±20% (M)	Inner lead (I)	5.0 mm (B) 7.5 mm (C)	5	2750	350	12 ±4	70 ±21	-40 to +200
ICL700D13abc	7	±20% (M)	Inner lead (I)	5.0 mm (B) 7.5 mm (C)	4	2800	350	12 ±4	70 ±21	-40 to +200
ICL800D13abc	8	±20% (M)	Inner lead (I)	5.0 mm (B) 7.5 mm (C)	4	2800	350	12 ±4	70 ±21	-40 to +200
ICL101D13abc	10	±20% (M)	Inner lead (I)	5.0 mm (B) 7.5 mm (C)	4	2850	350	12 ±4	70 ±21	-40 to +200
ICL121D13abc	12	±20% (M)	Inner lead (I)	5.0 mm (B) 7.5 mm (C)	4	2850	350	12 ±4	70 ±21	-40 to +200
ICL151D13abc	15	±20% (M)	Inner lead (I)	5.0 mm (B) 7.5 mm (C)	3	2900	350	12 ±4	70 ±21	-40 to +200
ICL161D13abc	16	±20% (M)	Inner lead (I)	5.0 mm (B) 7.5 mm (C)	3	2900	350	12 ±4	70 ±21	-40 to +200
ICL181D13abc	18	±20% (M)	Inner lead (I)	5.0 mm (B) 7.5 mm (C)	3	2950	350	12 ±4	70 ±21	-40 to +200
ICL201D13abc	20	±20% (M)	Inner lead (I)	5.0 mm (B) 7.5 mm (C)	3	3000	350	12 ±4	70 ±21	-40 to +200
ICL301D13abc	30	±20% (M)	Inner lead (I)	5.0 mm (B) 7.5 mm (C)	2.5	3100	350	12 ±4	70 ±21	-40 to +200
ICL501D13abc	50	±20% (M)	Inner lead (I)	5.0 mm (B) 7.5 mm (C)	2	3200	350	12 ±4	70 ±21	-40 to +200
ICL801D13abc	80	±20% (M)	Inner lead (I)	5.0 mm (B) 7.5 mm (C)	1.5	3300	350	12 ±4	70 ±21	-40 to +200
ICL102D13abc	100	±20% (M)	Inner lead (I)	5.0 mm (B) 7.5 mm (C)	1.5	3400	350	12 ±4	70 ±21	-40 to +200
ICL122D13abc	120	±20% (M)	Inner lead (I)	5.0 mm (B) 7.5 mm (C)	1.5	3400	350	12 ±4	70 ±21	-40 to +200
ICL070D15abc	0.7	±20% (M)	Inner lead (I)	5.0 mm (B) 7.5 mm (C)	8	2550	500	17 ±5	80 ±24	-40 to +200
ICL100D15abc	1	±20% (M)	Inner lead (I)	5.0 mm (B) 7.5 mm (C)	9	2600	500	17 ±5	80 ±24	-40 to +200
ICL130D15abc	1.3	±20% (M)	Inner lead (I)	5.0 mm (B) 7.5 mm (C)	9	2650	500	17 ±5	80 ±24	-40 to +200
ICL150D15abc	1.5	±20% (M)	Inner lead (I)	5.0 mm (B) 7.5 mm (C)	9	2650	500	17 ±5	80 ±24	-40 to +200

a= Enter resistance tolerance code from table above (M = ±20%)

b= Enter lead style code from table above (I= Inner lead)

c= Enter pin pitch code from table above (B = 5.0 mm, C = 7.5 mm)

Electrical specifications, cont.

Part number	Zero power resistance @ +25°C R ₂₅ (Ω)	Resistance tolerance (Part number code)	Lead style (Part number code)	Pin pitch (Part number code)	I _{max} (A)	Beta value (25/50) (K)	CT, maximum permissible capacitance at 240 Vac (μF)	Dissipation factor (mW/°C)	Thermal time constant T (second)	Operation temperature TL-TU(°C)
ICL200D15abc	2	±20% (M)	Inner lead (I)	5.0 mm (B) 7.5 mm (C)	8	2700	500	17 ±5	80 ±24	-40 to +200
ICL250D15abc	2.5	±20% (M)	Inner lead (I)	5.0 mm (B) 7.5 mm (C)	7.5	2700	500	17 ±5	80 ±24	-40 to +200
ICL300D15abc	3	±20% (M)	Inner lead (I)	5.0 mm (B) 7.5 mm (C)	7	2750	500	17 ±5	80 ±24	-40 to +200
ICL400D15abc	4	±20% (M)	Inner lead (I)	5.0 mm (B) 7.5 mm (C)	6.5	2800	500	17 ±5	80 ±24	-40 to +200
ICL500D15abc	5	±20% (M)	Inner lead (I)	5.0 mm (B) 7.5 mm (C)	6	2800	500	17 ±5	80 ±24	-40 to +200
ICL600D15abc	6	±20% (M)	Inner lead (I)	5.0 mm (B) 7.5 mm (C)	5.5	2850	500	17 ±5	80 ±24	-40 to +200
ICL700D15abc	7	±20% (M)	Inner lead (I)	5.0 mm (B) 7.5 mm (C)	5	2850	500	17 ±5	80 ±24	-40 to +200
ICL800D15abc	8	±20% (M)	Inner lead (I)	5.0 mm (B) 7.5 mm (C)	5	2900	500	17 ±5	80 ±24	-40 to +200
ICL101D15abc	10	±20% (M)	Inner lead (I)	5.0 mm (B) 7.5 mm (C)	5	2950	500	17 ±5	80 ±24	-40 to +200
ICL121D15abc	12	±20% (M)	Inner lead (I)	5.0 mm (B) 7.5 mm (C)	5	3000	500	17 ±5	80 ±24	-40 to +200
ICL151D15abc	15	±20% (M)	Inner lead (I)	5.0 mm (B) 7.5 mm (C)	4	3100	500	17 ±5	80 ±24	-40 to +200
ICL161D15abc	16	±20% (M)	Inner lead (I)	5.0 mm (B) 7.5 mm (C)	4	3100	500	17 ±5	80 ±24	-40 to +200
ICL201D15abc	20	±20% (M)	Inner lead (I)	5.0 mm (B) 7.5 mm (C)	4	3150	500	17 ±5	80 ±24	-40 to +200
ICL251D15abc	25	±20% (M)	Inner lead (I)	5.0 mm (B) 7.5 mm (C)	3.5	3200	500	17 ±5	80 ±24	-40 to +200
ICL301D15abc	30	±20% (M)	Inner lead (I)	5.0 mm (B) 7.5 mm (C)	3	3200	500	17 ±5	80 ±24	-40 to +200
ICL331D15abc	33	±20% (M)	Inner lead (I)	5.0 mm (B) 7.5 mm (C)	3	3200	500	17 ±5	80 ±24	-40 to +200
ICL471D15abc	47	±20% (M)	Inner lead (I)	5.0 mm (B) 7.5 mm (C)	3	3300	500	17 ±5	80 ±24	-40 to +200
ICL501D15abc	50	±20% (M)	Inner lead (I)	5.0 mm (B) 7.5 mm (C)	2.5	3400	500	17 ±5	80 ±24	-40 to +200
ICL601D15abc	60	±20% (M)	Inner lead (I)	5.0 mm (B) 7.5 mm (C)	2.5	3400	500	17 ±5	80 ±24	-40 to +200
ICL801D15abc	80	±20% (M)	Inner lead (I)	5.0 mm (B) 7.5 mm (C)	2.5	3450	500	17 ±5	80 ±24	-40 to +200

a= Enter resistance tolerance code from table above (M = ±20%)

b= Enter lead style code from table above (I= Inner lead)

c= Enter pin pitch code from table above (B = 5.0 mm, C = 7.5 mm)

Electrical specifications, cont.

Part number	Zero power resistance @ +25°C R ₂₅ (Ω)	Resistance tolerance (Part number code)	Lead style (Part number code)	Pin pitch (Part number code)	I _{max} (A)	Beta value (25/50) (K)	CT, maximum permissible capacitance at 240 Vac (μF)	Dissipation factor (mW/°C)	Thermal time constant T (second)	Operation temperature TL-TU(°C)
ICL102D15abc	100	±20% (M)	Inner lead (I)	5.0 mm (B) 7.5 mm (C)	2	3450	500	17 ±5	80 ±24	-40 to +200
ICL122D15abc	120	±20% (M)	Inner lead (I)	5.0 mm (B) 7.5 mm (C)	1.5	3500	500	17 ±5	80 ±24	-40 to +200
ICL070D18abc	0.7	±20% (M)	Inner lead (I)	5.0 mm (B) 7.5 mm (C)	15	2600	800	25 ±8	90 ±27	-40 to +200
ICL100D18abc	1	±20% (M)	Inner lead (I)	5.0 mm (B) 7.5 mm (C)	14	2650	800	25 ±8	90 ±27	-40 to +200
ICL150D18abc	1.5	±20% (M)	Inner lead (I)	5.0 mm (B) 7.5 mm (C)	12	2700	800	25 ±8	90 ±27	-40 to +200
ICL200D18abc	2	±20% (M)	Inner lead (I)	5.0 mm (B) 7.5 mm (C)	11	2750	800	25 ±8	90 ±27	-40 to +200
ICL250D18abc	2.5	±20% (M)	Inner lead (I)	5.0 mm (B) 7.5 mm (C)	10	2800	800	25 ±8	90 ±27	-40 to +200
ICL300D18abc	3	±20% (M)	Inner lead (I)	5.0 mm (B) 7.5 mm (C)	9	2800	800	25 ±8	90 ±27	-40 to +200
ICL400D18abc	4	±20% (M)	Inner lead (I)	5.0 mm (B) 7.5 mm (C)	8.5	2850	800	25 ±8	90 ±27	-40 to +200
ICL470D18abc	4.7	±20% (M)	Inner lead (I)	5.0 mm (B) 7.5 mm (C)	8	2850	800	25 ±8	90 ±27	-40 to +200
ICL500D18abc	5	±20% (M)	Inner lead (I)	5.0 mm (B) 7.5 mm (C)	7.5	2850	800	25 ±8	90 ±27	-40 to +200
ICL600D18abc	6	±20% (M)	Inner lead (I)	5.0 mm (B) 7.5 mm (C)	7	2900	800	25 ±8	90 ±27	-40 to +200
ICL680D18abc	7	±20% (M)	Inner lead (I)	5.0 mm (B) 7.5 mm (C)	7	2950	800	25 ±8	90 ±27	-40 to +200
ICL700D18abc	7	±20% (M)	Inner lead (I)	5.0 mm (B) 7.5 mm (C)	6.5	2950	800	25 ±8	90 ±27	-40 to +200
ICL800D18abc	8	±20% (M)	Inner lead (I)	5.0 mm (B) 7.5 mm (C)	6.5	3000	800	25 ±8	90 ±27	-40 to +200
ICL101D18abc	10	±20% (M)	Inner lead (I)	5.0 mm (B) 7.5 mm (C)	6	3100	800	25 ±8	90 ±27	-40 to +200
ICL121D18abc	12	±20% (M)	Inner lead (I)	5.0 mm (B) 7.5 mm (C)	5.5	3100	800	25 ±8	90 ±27	-40 to +200
ICL131D18abc	13	±20% (M)	Inner lead (I)	5.0 mm (B) 7.5 mm (C)	5.5	3150	800	25 ±8	90 ±27	-40 to +200
ICL151D18abc	15	±20% (M)	Inner lead (I)	5.0 mm (B) 7.5 mm (C)	5	3150	800	25 ±8	90 ±27	-40 to +200
ICL161D18abc	16	±20% (M)	Inner lead (I)	5.0 mm (B) 7.5 mm (C)	5	3200	800	25 ±8	90 ±27	-40 to +200

a= Enter resistance tolerance code from table above (M = ±20%)

b= Enter lead style code from table above (I= Inner lead)

c= Enter pin pitch code from table above (B = 5.0 mm, C = 7.5 mm)

Electrical specifications, cont.

Part number	Zero power resistance @ +25°C R ₂₅ (Ω)	Resistance tolerance (Part number code)	Lead style (Part number code)	Pin pitch (Part number code)	I _{max} (A)	Beta value (25/50) (K)	CT, maximum permissible capacitance at 240 Vac (μF)	Dissipation factor (mW/°C)	Thermal time constant T (second)	Operation temperature TL-TU(°C)
ICL181D18abc	18	±20% (M)	Inner lead (I)	5.0 mm (B) 7.5 mm (C)	5	3200	800	25 ±8	90 ±27	-40 to +200
ICL201D18abc	20	±20% (M)	Inner lead (I)	5.0 mm (B) 7.5 mm (C)	4.5	3200	800	30 ±9	100 ±30	-40 to +200
ICL301D18abc	30	±20% (M)	Inner lead (I)	5.0 mm (B) 7.5 mm (C)	4	3300	800	30 ±9	100 ±30	-40 to +200
ICL070D20abc	0.7	±20% (M)	Inner lead (I)	5.0 mm (B) 7.5 mm (C)	18	2650	1200	30 ±9	100 ±30	-40 to +200
ICL100D20abc	1	±20% (M)	Inner lead (I)	5.0 mm (B) 7.5 mm (C)	16	2700	1200	30 ±9	100 ±30	-40 to +200
ICL150D20abc	1.5	±20% (M)	Inner lead (I)	5.0 mm (B) 7.5 mm (C)	14	2750	1200	30 ±9	100 ±30	-40 to +200
ICL200D20abc	2	±20% (M)	Inner lead (I)	5.0 mm (B) 7.5 mm (C)	12.5	2800	1200	30 ±9	100 ±30	-40 to +200
ICL250D20abc	2.5	±20% (M)	Inner lead (I)	5.0 mm (B) 7.5 mm (C)	11.5	2850	1200	30 ±9	100 ±30	-40 to +200
ICL300D20abc	3	±20% (M)	Inner lead (I)	5.0 mm (B) 7.5 mm (C)	10.5	2850	1200	30 ±9	100 ±30	-40 to +200
ICL400D20abc	4	±20% (M)	Inner lead (I)	5.0 mm (B) 7.5 mm (C)	9.5	2900	1200	30 ±9	100 ±30	-40 to +200
ICL470D20abc	4.7	±20% (M)	Inner lead (I)	5.0 mm (B) 7.5 mm (C)	9	2950	1200	30 ±9	100 ±30	-40 to +200
ICL500D20abc	5	±20% (M)	Inner lead (I)	5.0 mm (B) 7.5 mm (C)	9	3000	1200	30 ±9	100 ±30	-40 to +200
ICL600D20abc	6	±20% (M)	Inner lead (I)	5.0 mm (B) 7.5 mm (C)	8.5	3050	1200	30 ±9	100 ±30	-40 to +200
ICL680D20abc	7	±20% (M)	Inner lead (I)	5.0 mm (B) 7.5 mm (C)	8	3100	1200	30 ±9	100 ±30	-40 to +200
ICL700D20abc	7	±20% (M)	Inner lead (I)	5.0 mm (B) 7.5 mm (C)	8	3100	1200	30 ±9	100 ±30	-40 to +200
ICL800D20abc	8	±20% (M)	Inner lead (I)	5.0 mm (B) 7.5 mm (C)	7.5	3100	1200	30 ±9	100 ±30	-40 to +200
ICL101D20abc	10	±20% (M)	Inner lead (I)	5.0 mm (B) 7.5 mm (C)	7	3150	1200	30 ±9	100 ±30	-40 to +200
ICL121D20abc	12	±20% (M)	Inner lead (I)	5.0 mm (B) 7.5 mm (C)	6.5	3200	1200	30 ±9	100 ±30	-40 to +200
ICL131D20abc	13	±20% (M)	Inner lead (I)	5.0 mm (B) 7.5 mm (C)	6.5	3200	1200	30 ±9	100 ±30	-40 to +200
ICL151D20abc	15	±20% (M)	Inner lead (I)	5.0 mm (B) 7.5 mm (C)	6	3200	1200	30 ±9	100 ±30	-40 to +200

a= Enter resistance tolerance code from table above (M = ±20%)

b= Enter lead style code from table above (I= Inner lead)

c= Enter pin pitch code from table above (B = 5.0 mm, C = 7.5 mm)

Electrical specifications, cont.

Part number	Zero power resistance @ +25°C R ₂₅ (Ω)	Resistance tolerance (Part number code)	Lead style (Part number code)	Pin pitch (Part number code)	I _{max} (A)	Beta value (25/50) (K)	CT, maximum permissible capacitance at 240 Vac (μF)	Dissipation factor (mW/°C)	Thermal time constant T (second)	Operation temperature TL-TU(°C)
ICL161D20abc	16	±20% (M)	Inner lead (I)	5.0 mm (B) 7.5 mm (C)	5.5	3200	1200	30 ±9	100 ±30	-40 to +200
ICL181D20abc	18	±20% (M)	Inner lead (I)	5.0 mm (B) 7.5 mm (C)	5.5	3300	1200	30 ±9	100 ±30	-40 to +200
ICL201D20abc	20	±20% (M)	Inner lead (I)	5.0 mm (B) 7.5 mm (C)	5.5	3300	1200	30 ±9	100 ±30	-40 to +200
ICL301D20abc	30	±20% (M)	Inner lead (I)	5.0 mm (B) 7.5 mm (C)	4	3400	1200	30 ±9	100 ±30	-40 to +200
ICL050D25abc	0.5	±20% (M)	Inner lead (I)	5.0 mm (B) 7.5 mm (C)	20	2650	2500	40 ±12	125 ±38	-40 to +200
ICL070D25abc	0.7	±20% (M)	Inner lead (I)	5.0 mm (B) 7.5 mm (C)	20	2700	2500	40 ±12	125 ±38	-40 to +200
ICL100D25abc	1	±20% (M)	Inner lead (I)	5.0 mm (B) 7.5 mm (C)	20	2750	2500	40 ±12	125 ±38	-40 to +200
ICL150D25abc	1.5	±20% (M)	Inner lead (I)	5.0 mm (B) 7.5 mm (C)	17	2800	2500	40 ±12	125 ±38	-40 to +200
ICL200D25abc	2	±20% (M)	Inner lead (I)	5.0 mm (B) 7.5 mm (C)	15	2850	2500	40 ±12	125 ±38	-40 to +200
ICL250D25abc	2.5	±20% (M)	Inner lead (I)	5.0 mm (B) 7.5 mm (C)	14	2900	2500	40 ±12	125 ±38	-40 to +200
ICL300D25abc	3	±20% (M)	Inner lead (I)	5.0 mm (B) 7.5 mm (C)	13	2950	2500	40 ±12	125 ±38	-40 to +200
ICL400D25abc	4	±20% (M)	Inner lead (I)	5.0 mm (B) 7.5 mm (C)	12	3050	2500	40 ±12	125 ±38	-40 to +200
ICL470D25abc	4.7	±20% (M)	Inner lead (I)	5.0 mm (B) 7.5 mm (C)	11.5	3100	2500	40 ±12	125 ±38	-40 to +200
ICL500D25abc	5	±20% (M)	Inner lead (I)	5.0 mm (B) 7.5 mm (C)	11	3100	2500	40 ±12	125 ±38	-40 to +200
ICL680D25abc	6.8	±20% (M)	Inner lead (I)	5.0 mm (B) 7.5 mm (C)	10	3150	2500	40 ±12	125 ±38	-40 to +200
ICL700D25abc	7	±20% (M)	Inner lead (I)	5.0 mm (B) 7.5 mm (C)	10	3150	2500	40 ±12	125 ±38	-40 to +200
ICL800D25abc	8	±20% (M)	Inner lead (I)	5.0 mm (B) 7.5 mm (C)	9.5	3200	2500	40 ±12	125 ±38	-40 to +200
ICL101D25abc	10	±20% (M)	Inner lead (I)	5.0 mm (B) 7.5 mm (C)	8.5	3200	2500	40 ±12	125 ±38	-40 to +200
ICL121D25abc	12	±20% (M)	Inner lead (I)	5.0 mm (B) 7.5 mm (C)	8	3300	2500	40 ±12	125 ±38	-40 to +200
ICL151D25abc	15	±20% (M)	Inner lead (I)	5.0 mm (B) 7.5 mm (C)	7.5	3300	2500	40 ±12	125 ±38	-40 to +200

a= Enter resistance tolerance code from table above (M = ±20%)
b= Enter lead style code from table above (I= Inner lead)
c= Enter pin pitch code from table above (B = 5.0 mm, C = 7.5 mm)

Electrical specifications, cont.

Part number	Zero power resistance @ +25°C R ₂₅ (Ω)	Resistance tolerance (Part number code)	Lead style (Part number code)	Pin pitch (Part number code)	I _{max} (A)	Beta value (25/50) (K)	CT, maximum permissible capacitance at 240 Vac (μF)	Dissipation factor (mW/°C)	Thermal time constant T (second)	Operation temperature TL~TU(°C)
ICL181D25abc	18	±20% (M)	Inner lead (I)	5.0 mm (B) 7.5 mm (C)	6.5	3400	2500	40 ±12	125 ±38	-40 to +200
ICL201D25abc	20	±20% (M)	Inner lead (I)	5.0 mm (B) 7.5 mm (C)	6	3400	2500	40 ±12	125 ±38	-40 to +200
ICL301D25abc	30	±20% (M)	Inner lead (I)	5.0 mm (B) 7.5 mm (C)	4.5	3450	2500	40 ±12	125 ±38	-40 to +200
ICL050D30abc	0.5	±20% (M)	Inner lead (I)	5.0 mm (B) 7.5 mm (C)	30	2700	3500	50 ±12	170 ±51	-40 to +200
ICL070D30abc	0.7	±20% (M)	Inner lead (I)	5.0 mm (B) 7.5 mm (C)	30	2750	3500	50 ±12	170 ±51	-40 to +200
ICL100D30abc	1	±20% (M)	Inner lead (I)	5.0 mm (B) 7.5 mm (C)	30	2800	3500	50 ±12	170 ±51	-40 to +200
ICL150D30abc	1.5	±20% (M)	Inner lead (I)	5.0 mm (B) 7.5 mm (C)	25	2850	3500	50 ±12	170 ±51	-40 to +200
ICL200D30abc	2	±20% (M)	Inner lead (I)	5.0 mm (B) 7.5 mm (C)	23	2950	3500	50 ±12	170 ±51	-40 to +200
ICL250D30abc	2.5	±20% (M)	Inner lead (I)	5.0 mm (B) 7.5 mm (C)	18	3000	3500	50 ±12	170 ±51	-40 to +200
ICL300D30abc	3	±20% (M)	Inner lead (I)	5.0 mm (B) 7.5 mm (C)	17	3100	3500	50 ±12	170 ±51	-40 to +200
ICL400D30abc	4	±20% (M)	Inner lead (I)	5.0 mm (B) 7.5 mm (C)	16	3150	3500	50 ±12	170 ±51	-40 to +200
ICL470D30abc	4.7	±20% (M)	Inner lead (I)	5.0 mm (B) 7.5 mm (C)	15	3150	3500	50 ±12	170 ±51	-40 to +200
ICL500D30abc	5	±20% (M)	Inner lead (I)	5.0 mm (B) 7.5 mm (C)	14	3200	3500	50 ±12	170 ±51	-40 to +200
ICL680D30abc	6.8	±20% (M)	Inner lead (I)	5.0 mm (B) 7.5 mm (C)	12	3200	3500	50 ±12	170 ±51	-40 to +200
ICL700D30abc	7	±20% (M)	Inner lead (I)	5.0 mm (B) 7.5 mm (C)	12	3200	3500	50 ±12	170 ±51	-40 to +200
ICL800D30abc	8	±20% (M)	Inner lead (I)	5.0 mm (B) 7.5 mm (C)	11	3300	3500	50 ±12	170 ±51	-40 to +200
ICL101D30abc	10	±20% (M)	Inner lead (I)	5.0 mm (B) 7.5 mm (C)	10	3300	3500	50 ±12	170 ±51	-40 to +200
ICL121D30abc	12	±20% (M)	Inner lead (I)	5.0 mm (B) 7.5 mm (C)	9	3400	3500	50 ±12	170 ±51	-40 to +200

a= Enter resistance tolerance code from table above (M = ±20%)

b= Enter lead style code from table above (I= Inner lead)

c= Enter pin pitch code from table above (B = 5.0 mm, C = 7.5 mm)

Electrical specifications, cont.

Part number	Zero power resistance @ +25°C R_{25} (Ω)	Resistance tolerance (Part number code)	Lead style (Part number code)	Pin pitch (Part number code)	I_{max} (A)	Beta value (25/50) (K)	CT, maximum permissible capacitance at 240 Vac (μ F)	Dissipation factor (mW/°C)	Thermal time constant T (second)	Operation temperature T_L ~ T_U (°C)
ICL151D30abc	15	±20% (M)	Inner lead (I)	5.0 mm (B) 7.5 mm (C)	8	3450	3500	50 ±12	170 ±51	-40 to +200
ICL181D30abc	18	±20% (M)	Inner lead (I)	5.0 mm (B) 7.5 mm (C)	8	3450	3500	50 ±12	170 ±51	-40 to +200
ICL201D30abc	20	±20% (M)	Inner lead (I)	5.0 mm (B) 7.5 mm (C)	7	3450	3500	50 ±12	170 ±51	-40 to +200
ICL301D30abc	30	±20% (M)	Inner lead (I)	5.0 mm (B) 7.5 mm (C)	5.5	3600	3500	50 ±12	170 ±51	-40 to +200

- a= Enter resistance tolerance code from table above (M = ±20%)
- b= Enter lead style code from table above (I= Inner lead)
- c= Enter pin pitch code from table above (B = 5.0 mm, C = 7.5 mm)

Derating curve

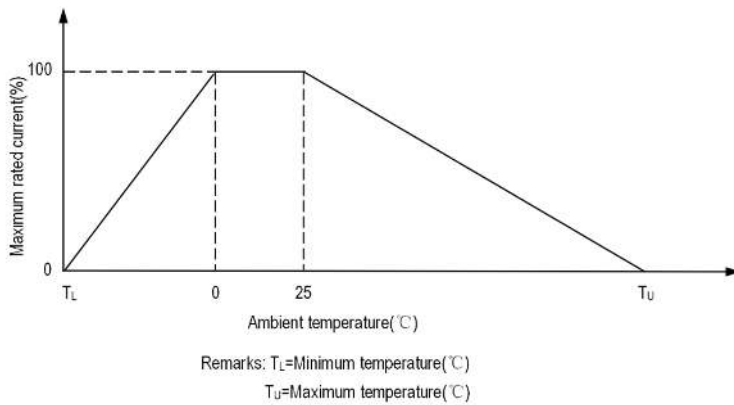

Temperature characteristics

R-T curve

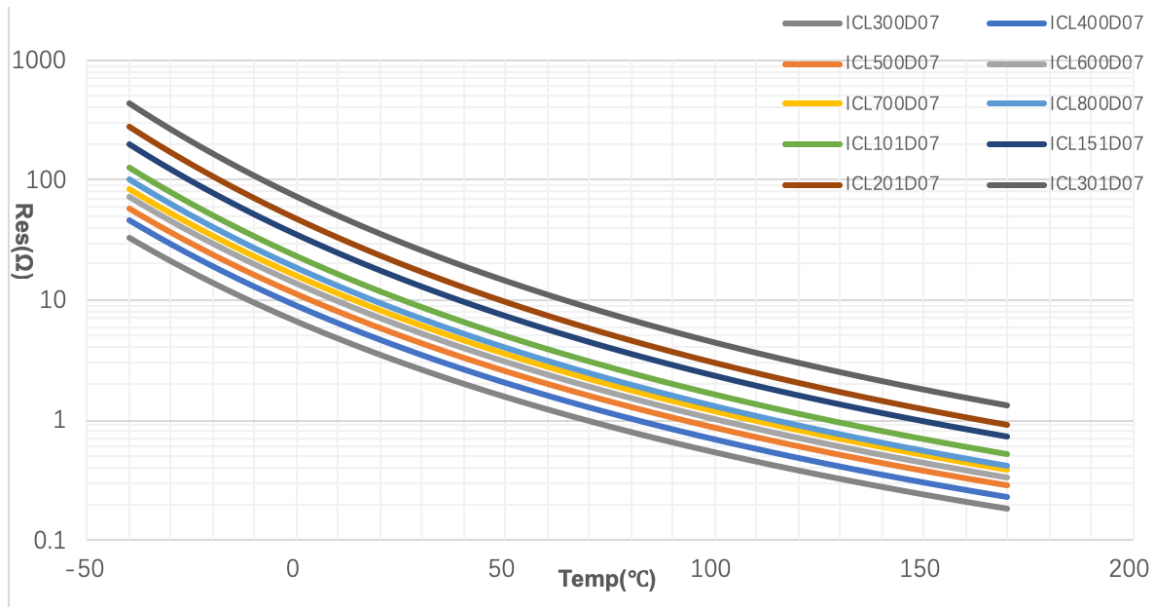
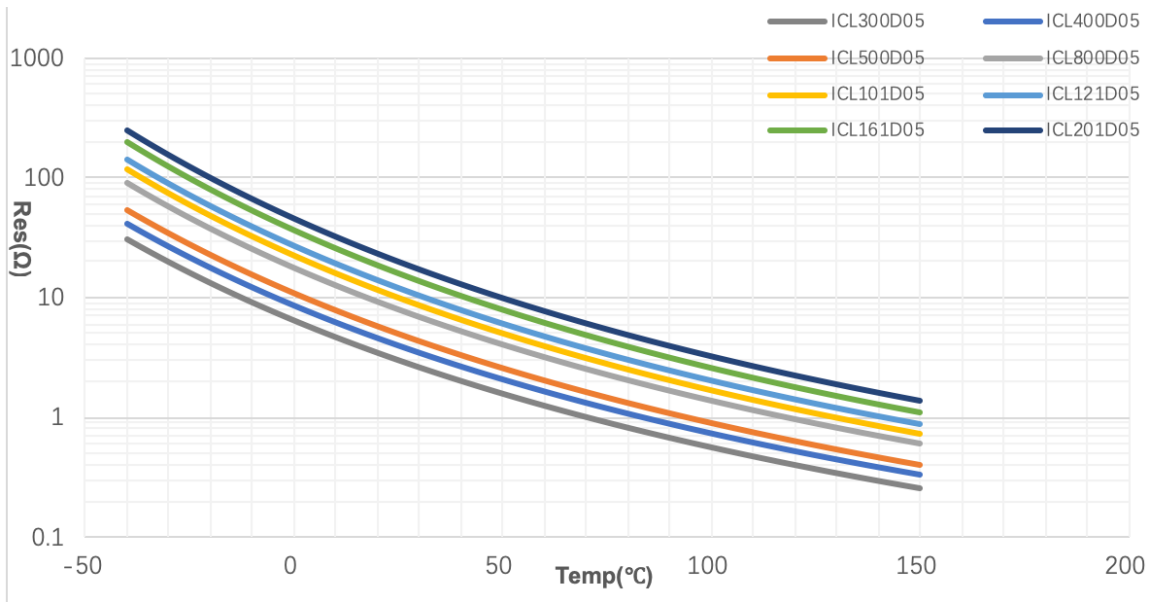

Temperature characteristics

R-T curve

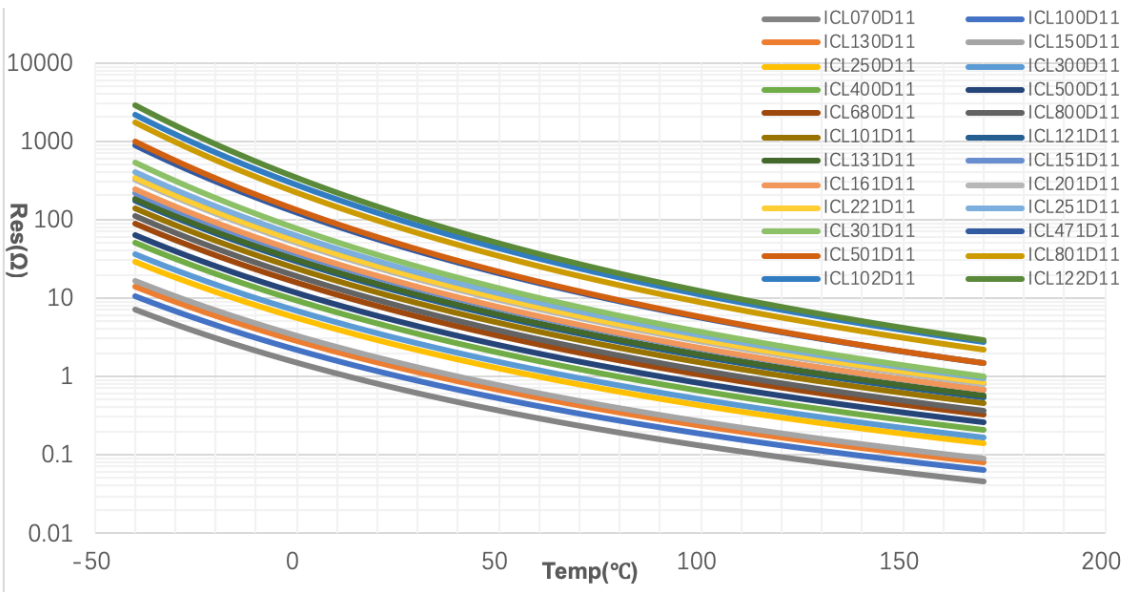
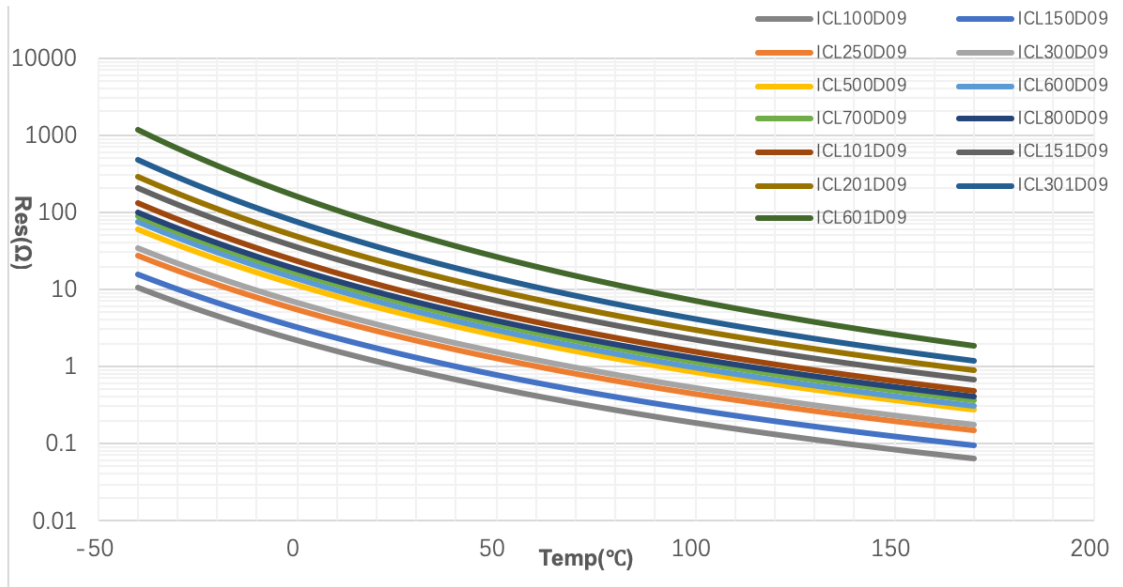

Temperature characteristics, cont.

R-T curve

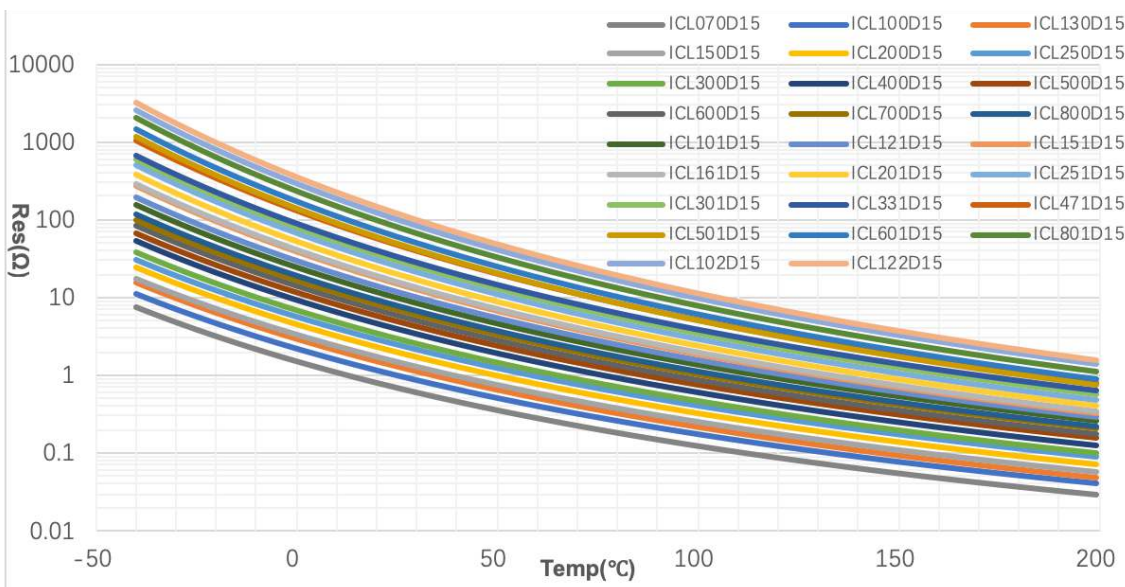
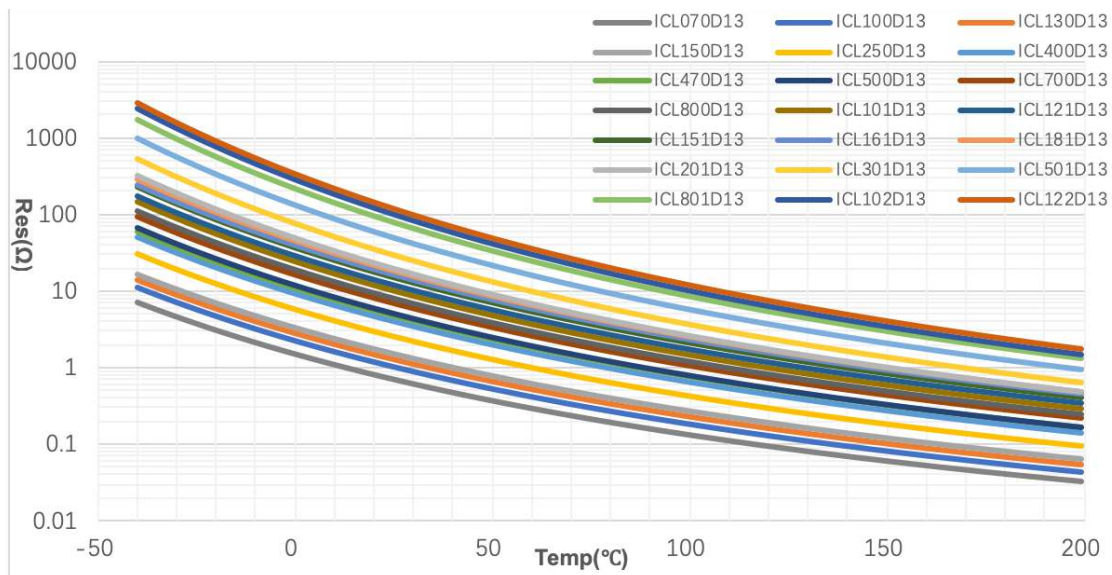

Temperature characteristics

R-T curve

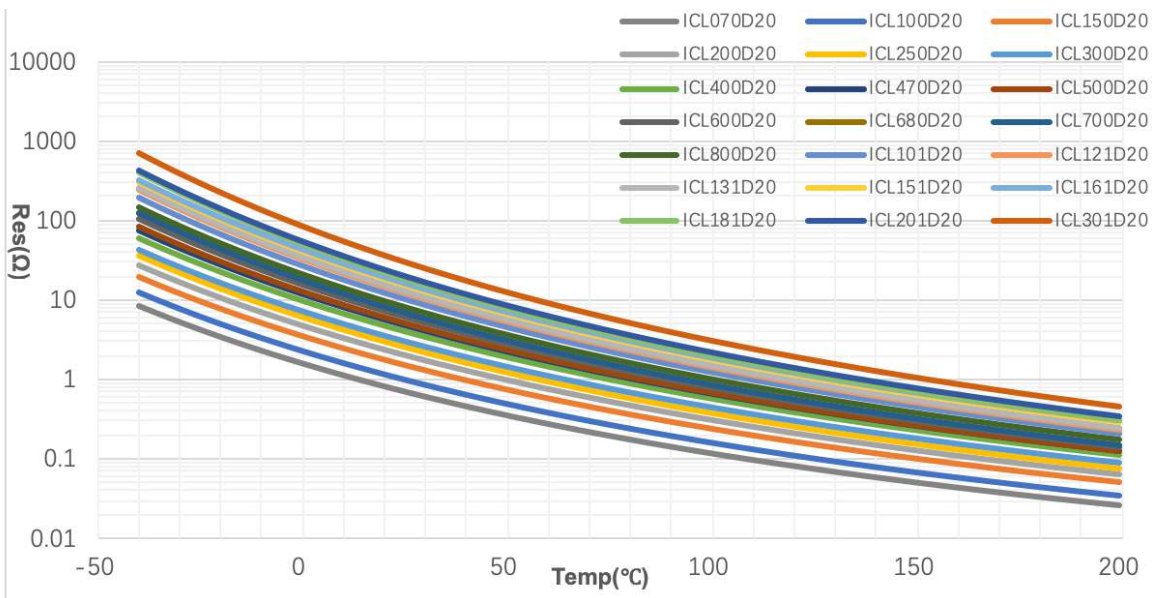
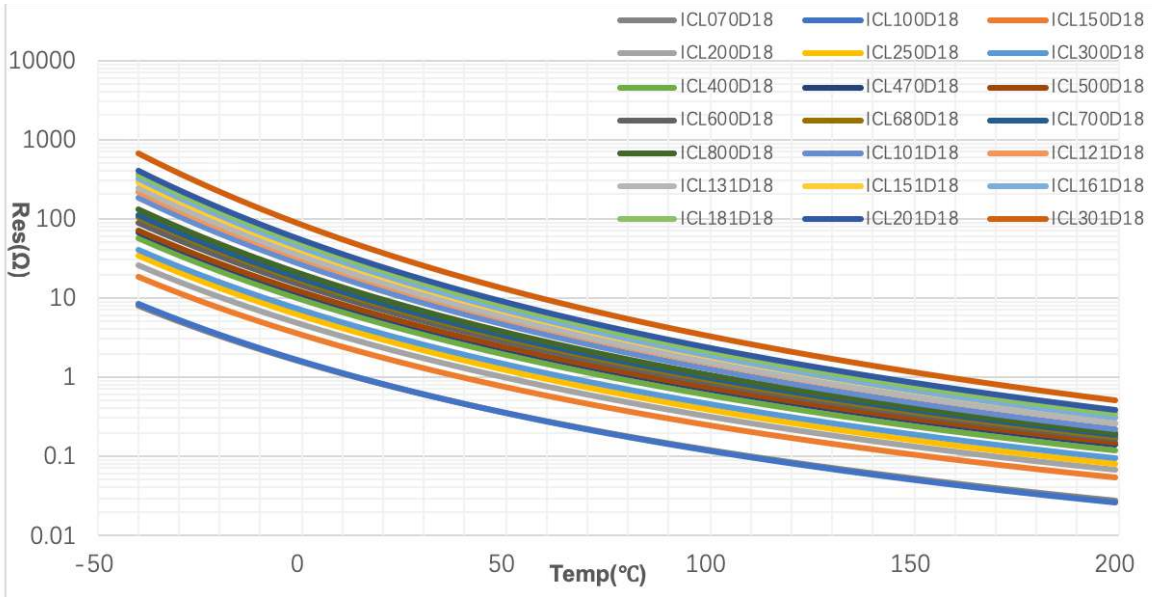

Temperature characteristics

R-T curve

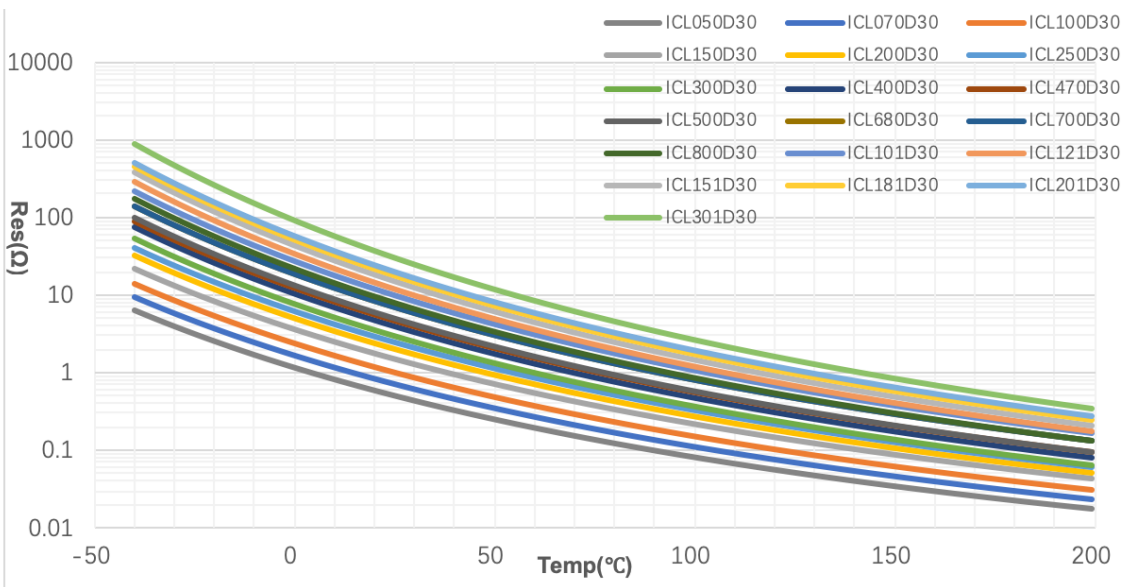
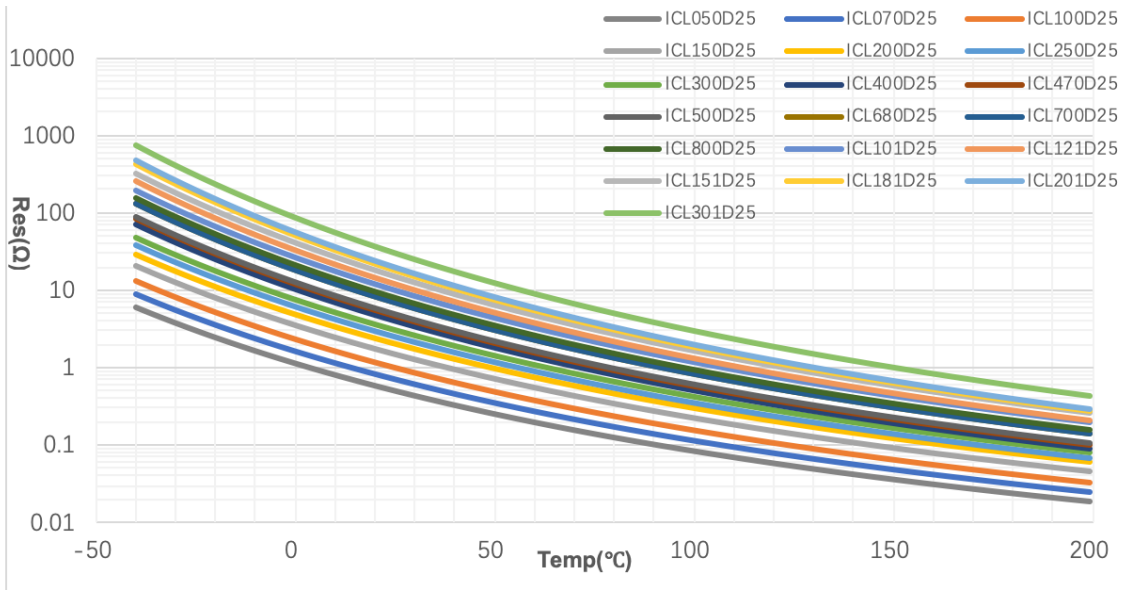

Wave solder profile

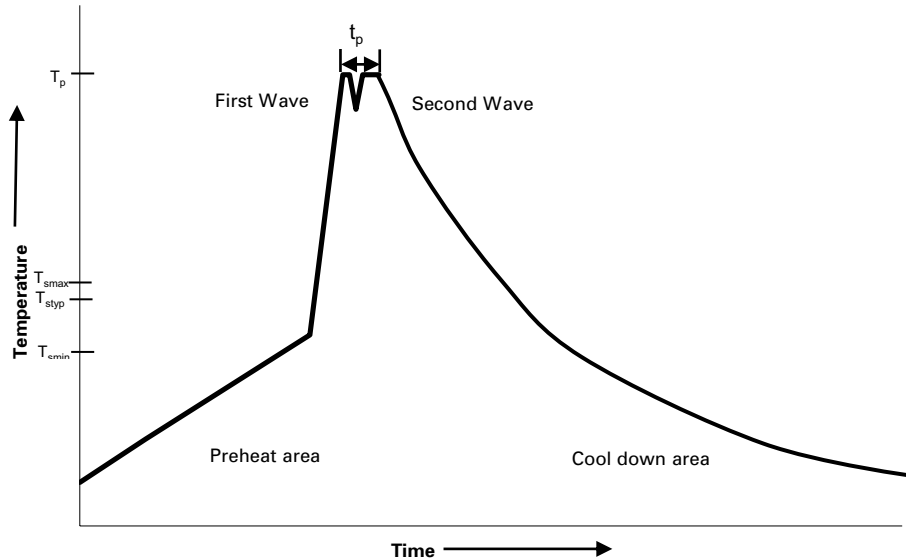

Reference EN 61760-1:2006

Profile feature	Standard SnPb solder	Lead (Pb) free solder
Preheat		
• Temperature min. (T_{smin})	100 °C	100 °C
• Temperature typ. (T_{styp})	120 °C	120 °C
• Temperature max. (T_{smax})	130 °C	130 °C
• Time (T_{smin} to T_{smax}) (t_s)	70 seconds	70 seconds
Δ preheat to max Temperature	150 °C max.	150 °C max.
Peak temperature (T_p)*	235 °C – 260 °C	250 °C – 260 °C
Time at peak temperature (t_p)	10 seconds max 5 seconds max each wave	10 seconds max 5 seconds max each wave
Ramp-down rate	~ 2 K/s min ~3.5 K/s typ ~5 K/s max	~ 2 K/s min ~3.5 K/s typ ~5 K/s max
Time 25 °C to 25 °C	4 minutes	4 minutes

Manual solder

+360 °C (3 seconds maximum by soldering iron distance between soldering position and coating 2 mm minimum), generally manual/hand soldering is not recommended.

Life Support Policy: Eaton does not authorize the use of any of its products for use in life support devices or systems without the express written approval of an officer of the Company. Life support systems are devices which support or sustain life, and whose failure to perform, when properly used in accordance with instructions for use provided in the labeling, can be reasonably expected to result in significant injury to the user.

Eaton reserves the right, without notice, to change design or construction of any products and to discontinue or limit distribution of any products. Eaton also reserves the right to change or update, without notice, any technical information contained in this bulletin.

Eaton
Electronics Division
1000 Eaton Boulevard
Cleveland, OH 44122
United States
Eaton.com/electronics

© 2022 Eaton
All Rights Reserved
Printed in USA
Publication No. ELX1228 BU-ELX22088
July 2022

Eaton is a registered trademark.
All other trademarks are property of their respective owners.

Follow us on social media to get the latest product and support information.

