TPS2490 and TPS2491

+48 V Hot Swap Power Manager Evaluation Kit

User's Guide

Contents

1	Introduction	1-1
1.1	Features	1-2
1.2	Applications	1-2
1.3	Description	1-2
2	The +48 V Hot Swap EVM Kit	2-1
2.1	The +48 V Hot Swap EVM Main Board	2-2
2.1.1	Module Description	2-2
2.1.2	EVM Schematic Diagram and Bill of Materials	2-4
2.2	The +48 V EVM Backplane Board	2-6
2.2.1	Description	2-6
2.2.2	Backplane Board Schematic Diagram and Bill of Materials (BOM)	2-7
2.3	+48 V Hot-Swap EVM Operating Specifications	2-8
3	Getting Started	3-1
3.1	Equipment Requirements	3-2
3.2	Verifying the EVM Operation	3-2
3.2.1	Equipment Setup	3-2
3.2.2	Functional Test	3-3
4	Using the EVM Kit to Evaluate the TPS2490/91 HSPM IC	4-1
4.1	Test Points	4-2
4.2	Input and Output Capacitors	4-2
4.3	TIMER Capacitor	4-3
4.4	PROG Capacitor	4-3
4.5	GATE Capacitor	4-3
4.6	Evaluation Without the Backplane Board	4-3

Figures

2-1	Evaluation Module Main Board Top Assembly	2-3
2-2	+48 V Hot-Swap Power Manager Evaluation Module Main Board Schematic	2-4
2-3	EVM Backplane Board Top Assembly	2-6
2-4	EVM Backplane Board Schematic	2-7
3-1	+48 V Hot-Swap EVM Setup	3-2
3-2	Output Ramp-Up Sequence Waveforms Without Resistive Load, Enabled by SW1	3-4

Tables

2-1	+48 V Hot-Swap Evaluation Module Main Board Bill of Materials (HPA016-001, -002) .	2-5
2-2	+48 V Hot-Swap Evaluation Module Backplane Board Bill of Materials (HPA018-001) . .	2-8
2-3	EVM Absolute Maximum Ratings	2-8
2-4	+48 V EVM Recommended Operating Conditions	2-8
3-1	TPS2490EVM or TPS2491EVM DMM Readings—Output OFF	3-3
3-2	TPS2490EVM or TPS2491EVM DMM Readings—Output ON	3-3
4-1	+48 V Hot Swap EVM Backplane Board Test Points	4-2
4-2	+48 V Hot Swap EVM Main Board Test Points	4-2

Introduction

The +48 V hot swap power manager evaluation module (EVM) is a two-board platform that enables designers to rapidly learn about and evaluate the performance of the TPS2490 or TPS2491. Texas Instruments (TI) TPS2490 and TPS2491 +48 V hot swap power manager integrated circuits (ICs) ensure the hot-swap safety and add protection during fault conditions for boards or modules in +48 V hot swap environments. The ICs feature programmable current and power limiting, electronic circuit breaker, adjustable undervoltage-lock enable input, and power-good reporting output. The +48 V hot swap EVM is a PCB-based tool used to demonstrate the performance and operation of the TPS2490 and TPS2491 ICs in simulated live insertion and removal actions.

Topic	Page
1.1 Features	1-2
1.2 Application	1-2
1.3 Description	1-2

1.1 Features

The following list highlights some of the features of the TPS2490 and TPS2491 IC.

- Allows Safe Board Insertion and Removal From a Live Backplane
- High-Side Drive for Low- $R_{DS(on)}$ External N-channel MOSFET
- Programmable Current Limiting and Power Limiting for Complete SOA Protection
- Programmable Fault Timer to Eliminate Nuisance Shutdowns
- Programmable Undervoltage Lockout
- High-voltage Operating Range: 9 V to 80 V
- 100-V Maximum Input Voltage
- Power Good Open-Drain Output
- Input Undervoltage Lockout
- Latched Operation Mode (TPS2490)
- Automatic Retry Mode (TPS2491)
- Available in 10-pin MSOP
- -40°C to 85°C Ambient Temperature Range
- 2-kV Human-Body-Model, 500-V CDM Electrostatic Discharge Protection

1.2 Applications

- Boards or Modules in +48 V Hot Swap Environments

1.3 Description

The TPS2490 and TPS2491 +48 V hot swap power manager (HSPM) provides highly integrated supply control of 9-V to 80-V positive supplies with a minimum number of external components. These hot-swap controllers operate an external N-channel MOSFET device to safely switch power to downstream loads. A power MOSFET can be destroyed if operated outside its safe operating area (SOA) curve, which typically includes limitations on current, voltage and power. In order to assure that the SOA is not exceeded, the hot-swap controller contains independently adjustable current- and power-limit circuitry. If a fault persists beyond a user-defined period of time, the HSPM turns off the power MOSFET. Depending upon which design option is chosen, the part either remains latched off (TPS2490) until the enable is cycled, or it automatically restarts (TPS2491) after a time delay.

These devices can be used on plug-in cards and on back-planes to limit inrush current, control load turn-on, enable down-stream dc-to-dc converters, isolate faulted loads, and eliminate nuisance shutdowns.

The +48 V Hot Swap EVM Kit

The main evaluation board (TI part number HPA016) contains the power interface section of a plug-in card as it may be implemented in a typical, compliant hot swap system. The EVM backplane board (TI part number HPA018) provides a mechanism for simulating hot swap events by abruptly applying power, ground, and control signals on the backplane board to their corresponding inputs on the main EVM board inserted into the backplane board P1B connector.

Topic	Page
2.1 The +48-V Hot Swap EVM Main Board	2-2
2.2 The +48-V EVM Backplane Board	2-6
2.3 +48-V Hot-Swap EVM Operating Specifications	2-8

2.1 The +48 V Hot Swap EVM Main Board

2.1.1 Module Description

The +48 V EVM main board contains the power isolation and control electronics comprising a hot swap interface that may be incorporated in a +48 V hot swap plug-in board. The EVM main board contains a TPS2490 or TPS2491 48-V HSPM IC, a power MOSFET switch, and some configuration capacitors. In addition, the main board contains some additional switches, jacks, headers, and components that can be used to facilitate device testing and for quick modifications of the plug-in characteristics.

The layout of the EVM main board top assembly is shown in Figure 2–1.

Figure 2–1. Evaluation Module Main Board Top Assembly

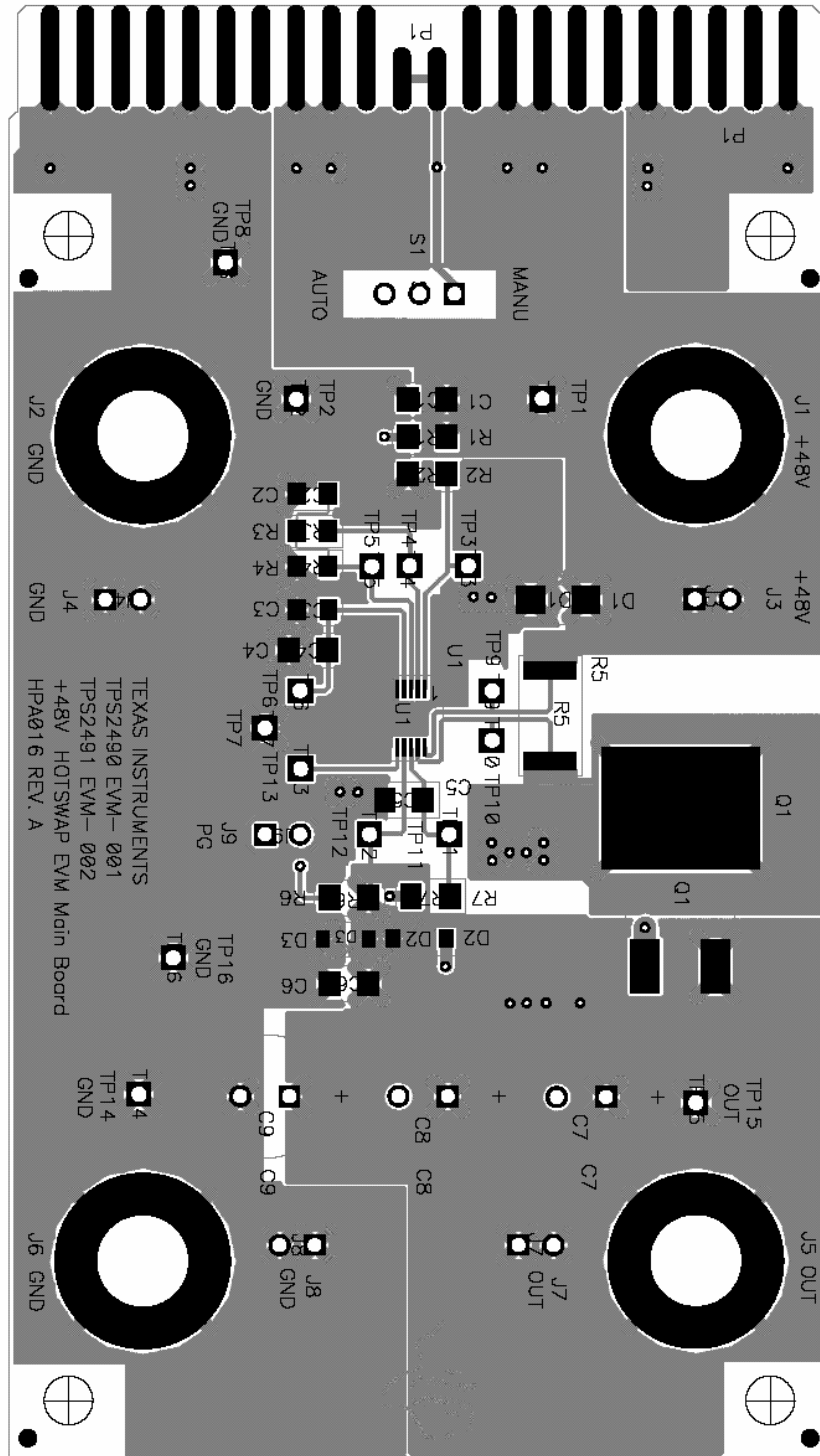

Test points are provided throughout the EVM main board for monitoring. The test points are listed in Table 4–2.

2.1.2 EVM Schematic Diagram and Bill of Materials

The EVM main board schematic diagram is shown in Figure 2–2.

Figure 2–2. +48 V Hot-Swap Power Manager Evaluation Module Main Board Schematic

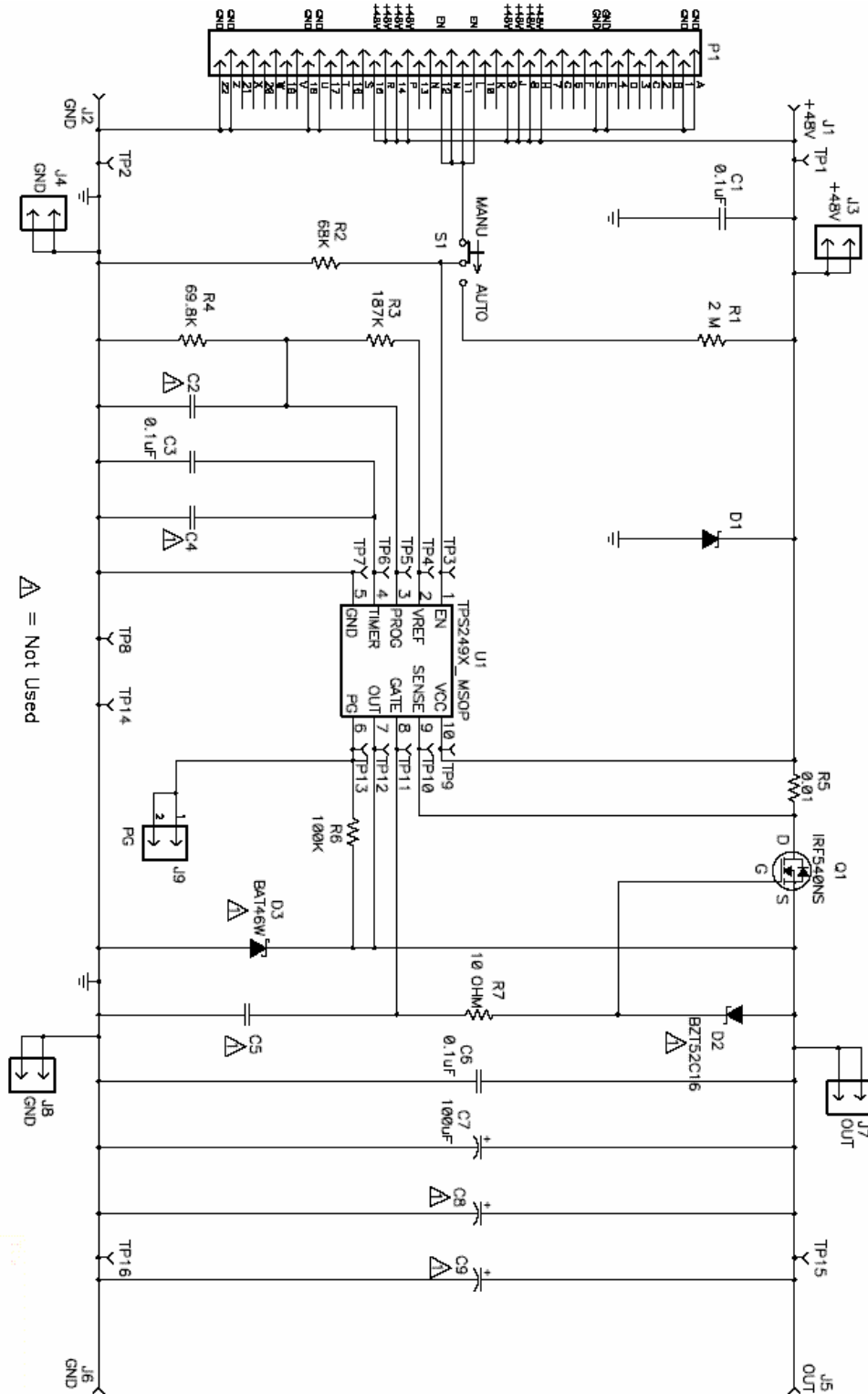

The +48 V Hot Swap EVM Main Board Bill of Materials (BOM) is shown in Table 2-1.

Table 2-1. +48 V Hot-Swap Evaluation Module Main Board Bill of Materials (HPA016-001, -002)

Count		RefDes	Description	Size	Part Number	MFR
-002	-001					
2	2	C1, C6	Capacitor, ceramic, 0.1 μ F, 100 V, X7R, 10%	1206	ECJ-3YBZA104K	Panasonic
0	0	C2	Capacitor	805		
1	1	C3	Capacitor, Ceramic, 0.1 μ F, 16 V, 10%	805	ECJ-ZVF1C104Z	Panasonic
0	0	C4, C5	Capacitor	1206		
1	1	C7,	Capacitor, Panasonic, 100 μ F, 100 V, 20%	TH	ECA-ZAM101	Panasonic
0	0	C8,C9	Capacitor center 140 mil	TH		
1	1	D1	Diode, Zener, 80 V, 400 W	SMA	SMAT70A	Diodes
0	0	D2	Diode	SM		
0	0	D3	Diode	SM		
4	4	J1, J2, J5, J6	Connector, banana jack, uninsulated		3267	Pomona
5	5	J3, J4, J7, J8, J9	Header, 2-pin, 100 mil spacing		PTC36SAAN	Sullins
1	1	Q1	Transistor, NFET, 100 V, 33 A, 44 m Ω	D2PAK	IRF540NS	IR
1	1	R1	Resistor, chip, 2 M Ω , 1/8 W, 1%	1206	Std	Std
1	1	R2	Resistor, chip, 68 k Ω , 1/4 W, 1%	1206	Std	Std
1	1	R3	Resistor, chip, 187 k Ω , 1/10 W, 1%	805	Std	Std
1	1	R4	Resistor, chip, 69.8 k Ω , 1/10 W, 1%	805	Std	Std
1	1	R5	Resistor, metal strip, 0.01 Ω , 2 W, 1%	2512	LCR-LRF2512-01-R010-F	IRC
1	1	R6	Resistor, chip, 100 k Ω , 1/8 W, 5%	1206	Std	Std
1	1	R7	Resistor, chip, 10 Ω , 1/8 W, 5%	1206	Std	Std
1	1	S1	Switch, 1P2T, slide, PC-mount, 200 mA		EG1218	E_Switch
11	11	TP1, TP3, TP4, TP5, TP6, TP9, TP10, TP11, TP12, TP13, TP15	Test point, red, 1 mm		240-345	Farnell
5	5	TP2, TP7, TP8, TP14, TP16	Test point, black, 1 mm		240-333	Farnell
0	1	U1	IC TPS2490DGS	DGS10	TPS2490DGS	TI
1	0	U1	IC TPS2491DGS	DGS10	TPS2491DGS	TI
1	1	---	PCB, 3.816 in \times 2.336 in \times 0.062 in		HPA016	Any
4	4	NA	Spacer, nylon, Hex, #6-32, 0.625		14HTSP020	
4	4	NA	Screw, nylon, and HD, #6-32, 0.025		010632R025	
1	1		HPA018 ASSEMBLY REQUIRED			

2.2 The +48 V EVM Backplane Board

2.2.1 Description

The EVM backplane board is used to present the backplane of a +48 V hot-swap system. The backplane contains banana jacks and headers for the connection of a +48 V power supply. The board has a 44-pin PCB edge connector (P1B). Inserting and removing the EVM main board into and out of the backplane board P1B connector simulates hot-swap events.

The pictorial of the EVM backplane board top assembly is shown in Figure 2–3.

Figure 2–3. EVM Backplane Board Top Assembly

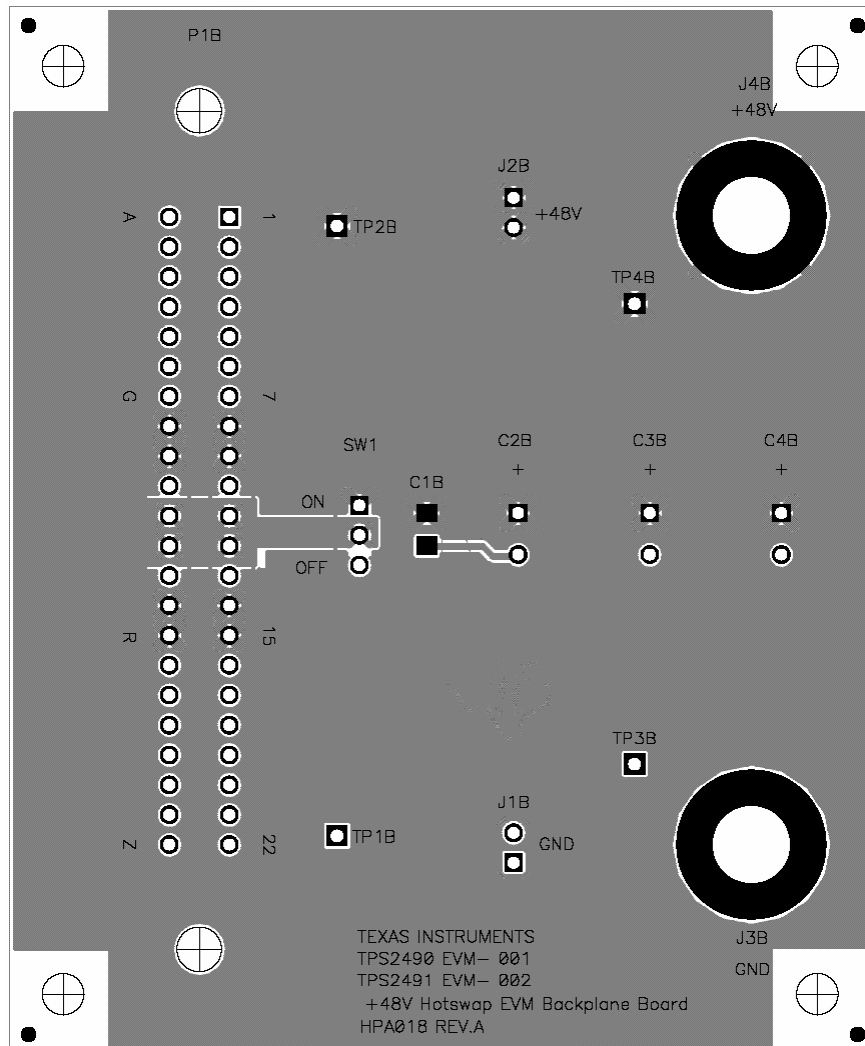

Test points are also provided throughout the EVM backplane board for monitoring as listed in Table 4–1.

2.2.2 Backplane Board Schematic Diagram and Bill of Materials (BOM)

The EVM backplane board schematic diagram is shown in Figure 2–4.

Figure 2–4. EVM Backplane Board Schematic

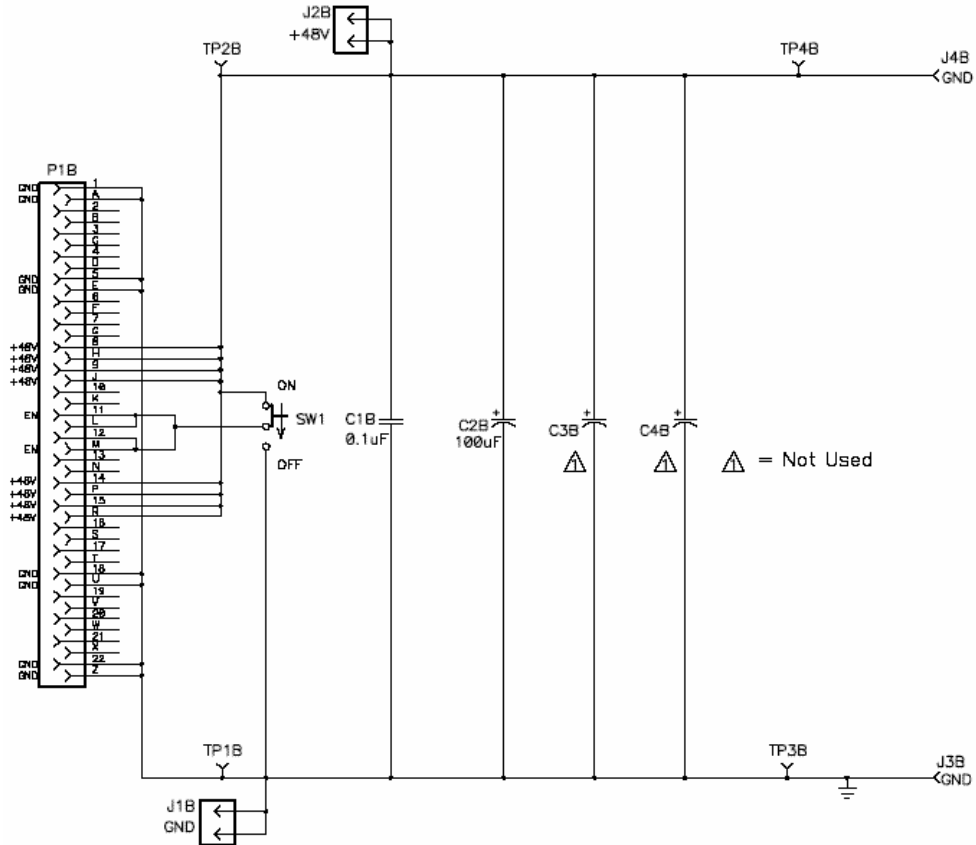

The EVM backplane board bill of materials (BOM) is shown in Table 2–2.

Table 2–2. +48 V Hot-Swap Evaluation Module Backplane Board Bill of Materials (HPA018–001)

Count	RefDes	Description	Size	Part Number	MFR
1	C1B	Capacitor, ceramic, 0.1 μ F, 100 V, X7R, 10%	1206	ECJ–3YB2A104K	Panasonic
1	C2B,	Capacitor, Panasonic, 100 μ F, 100 V, 20%	TH	ECA–ZAM101	Panasonic
0	C3B, C4B	Capacitor center 140 mils	TH		
2	J1B, J2B	Header, 2-pin, 100 mil spacing	TH	PTC36SAAN	Sullins
2	J3B, J4B	Connector, banana jack, uninsulated		3267	Pomona
1	P1B	Connector, 44-pin edge with mtg tabs (for 0.062 PCB)”	TH	50–22SN–11	Cinch
1	SW1	Switch, 1P2T, slide, PC-mount, 200 mA	TH	EG1218	E_Switch
2	TP1B,TP3B	Test point, black, 1 mm	TH	240–333	Farnell
2	TP2B,TP4B	Test point, red, 1 mm	TH	240–345	Farnell
1	NA	PCB, 2.9 In \times 3.5 In \times 0.062 In		HPA018	Any
4	NA	Spacer, nylon, Hex, #6–32, 0.625		14HTSP020	Eagle
4	NA	Screw, nylon, and, Hd, #6–32, 0.25		010632R025	Eagle

2.3 +48 V Hot-Swap EVM Operating Specifications

The EVM main board and backplane board were designed for some degree of user reconfiguration, as described later in Chapter 4, when using the EVM to evaluate the TPS2490 and TPS2491 HSPM ICs. This includes modifications for different load current requirements. However, under no circumstances should the EVM kit be operated beyond the input supply and load currents specified in Table 2–3.

Table 2–3. EVM Absolute Maximum Ratings

Parameter	Min	Max	Units
Supply voltage range, J4B (+48VIN)	–0.3	100	V
Load current, J5 (OUT)	0	Limited	A
Ambient operating temperature range	–40	85	$^{\circ}$ C

- Notes:**
- 1) All voltages are with respect PCB GND node, J1B, J3B, J4 or J6.
 - 2) Currents are positive into and negative out of the specified terminal.
 - 3) The EVM contains clamping circuitry to clamp the voltage of the TPS2490 and TPS2491 V_{CC} input below 80 V. The EVM can survive transient voltage excursions at J5 and J6 beyond the dc limits specified in Table 2–3.

Component selection for the EVM was done to configure the circuit for a typical +48 V application. As such, the target operating conditions, to the factory-installed component values, are as shown in Table 2–4.

Table 2–4. +48 V EVM Recommended Operating Conditions

Parameter	Min	Nom	Max	Units		
Nominal supply voltage, +48VIN	Enabling by SW1, S1 in MANU		10	48	70	V
	Enabling by S1, SW1 in OFF		42	48	70	V
Load current, OUT	0		4		A	

- Notes:**
- 1) All voltages are with respect PCB GND node, J1B, J3B, J4 or J6.
 - 2) Currents are positive into and negative out of the specified terminal.

Getting Started

This chapter describes the test environment for using the EVM. Other required test equipment includes a lab power supply, oscilloscope, and multiple digital voltmeters.

Topic	Page
3.1 Equipment Requirements	3-2
3.2 Verifying the EVM Operation	3-2

3.1 Equipment Requirements

The following test equipment is required to use the EVM kit.

- Power supply, 60 VDC at 6 amp minimum
- Oscilloscope, 4 channel preferred (3 voltage probes and 1 current probe)
- Digital voltmeter (DVM)

The availability of additional DVMs simplifies EVM use.

3.2 Verifying the EVM Operation

The following procedure steps may be used to verify functional operation of the EVM after receipt.

3.2.1 Equipment Setup

- 1) Do not connect the power supply to the EVM boards (HPA016 and HPA018).
- 2) If installed, remove the EVM main board (HPA016) from the P1B connector of the EVM backplane board (HPA018).
- 3) On the EVM main board (HPA016), set switch S1 to MANU.
- 4) On the EVM backplane board (HPA018), set switch SW1 to OFF.
- 5) Turn on the power supply. Set the output voltage of the supply to 48 ± 0.2 VDC. On the supply, verify the output current limit control is set to allow sourcing of at least 6 A.
- 6) Turn off the power supply. Connect the power supply to the EVM backplane board (HPA018) as shown in Figure 3–1.

Figure 3–1. +48 V Hot-Swap EVM Setup

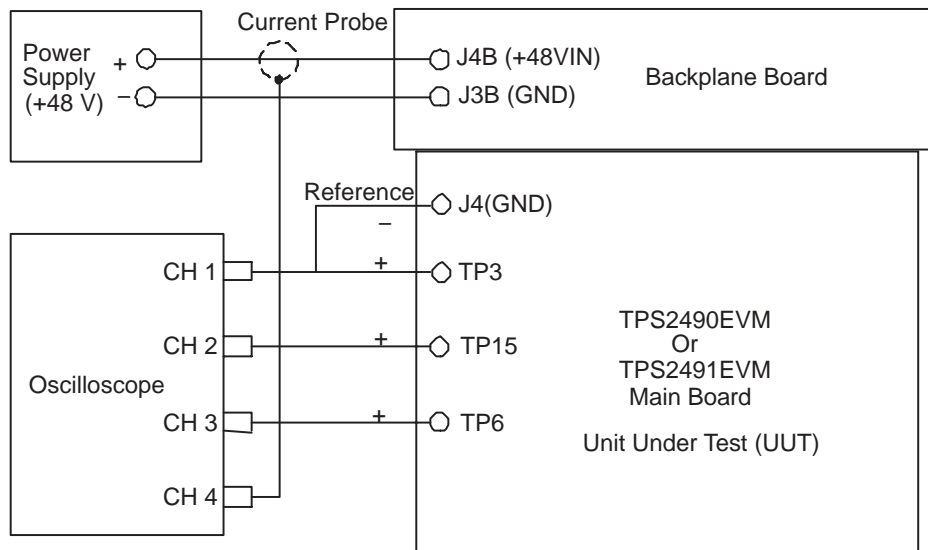

3.2.2 Functional Test

- 1) Plug the EVM main board (HPA016) into the EVM backplane board (HPA018) P1B connector. Due to the symmetric design of the connector, the board can be inserted in either direction.
- 2) Connect the oscilloscope probes as shown in Figure 3–1.
- 3) Set the oscilloscope channel amplifiers to the following scale settings:
 - a) CH1: 50 V/div at first line
 - b) CH2: 20 V/div at fourth line
 - c) CH3: 2 V/div at fifth line
 - d) CH4: 2 A/div at position just above the bottom line (eighth line)
- 4) Set the oscilloscope timebase to 1 ms/div.
- 5) Set the scope to trigger on the rising edge of Channel 1 at about a 20-V level and 10% horizontal trigger position.
- 6) Set the mode to NORMAL.
- 7) Turn on the power supply. Verify that the voltages shown in Table 3–1 are obtained on each DMM display.

Table 3–1. TPS2490EVM or TPS2491EVM DMM Readings—Output OFF

DMM #	Test Points	Voltage Reading
DMM1	On HPA018: TP2B +, TP1B – (INPUT Voltage)	48± 0.5 VDC
DMM2	On HPA016: TP12 +, TP16 – (OUT Voltage)	0 ± 1.0 VDC
DMM3	On HPA016: TP5 +, TP8 – (PROG Voltage)	0 ± 0.1 VDC
DMM4	On HPA016: TP13 +, TP14 – (PG Voltage)	0 ± 0.1 VDC
DMM5	On HPA016: TP4 +, TP2 – (VREF Voltage)	4.0 ± 0.1 VDC
DMM6	On HPA016: TP11 +, TP7 – (GATE Voltage)	0 ± 0.1 VDC

- 8) On the EVM backplane board (HPA018), place the SW1 switch in the ON position. Moving the DMM lead connections as required, verify that the voltages shown in Table 3–2 are obtained on each DMM display.

Table 3–2. TPS2490EVM or TPS2491EVM DMM Readings—Output ON

DMM #	Test Points	Voltage Reading
DMM1	On HPA018: TP2B +, TP1B – (INPUT Voltage)	48± 0.5 VDC
DMM2	On HPA016: TP12 +, TP16 – (OUT Voltage)	48 ± 1.0 VDC
DMM3	On HPA016: TP5 +, TP8 – (PROG Voltage)	1.05 ± 0.1 VDC
DMM4	On HPA016: TP13 +, TP14 – (PG Voltage)	48 ± 0.1 VDC
DMM5	On HPA016: TP4 +, TP2 – (VREF Voltage)	4.0 ± 0.1 VDC
DMM6	On HPA016: TP11 +, TP7 – (GATE Voltage)	62 ± 2.0 VDC

- 9) On the oscilloscope, verify a sweep was obtained which is similar to the one shown in Figure 3–2. Verify that the total turnon time, t_{ST} , as defined in Figure 3–2, is 2.5 ± 1.0 ms.

- 10) Return SW1 to OFF position. Unplug the EVM main board (HPA016) from the P1B socket of the EVM backplane board.
- 11) Turn off the power supply and disconnect the cables from the EVM boards if no further tests are planned.

Figure 3–2. Output Ramp-Up Sequence Waveforms Without Resistive Load, Enabled by SW1

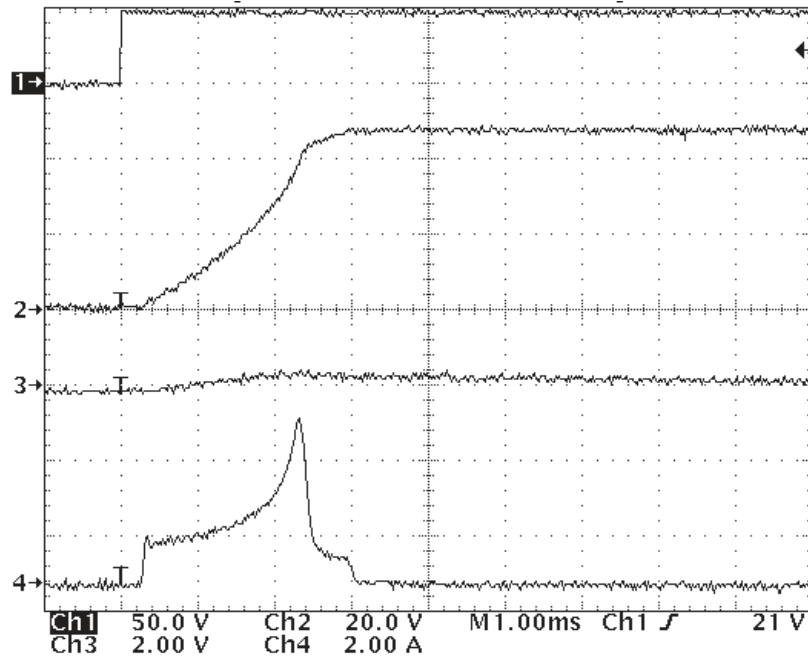

Using the EVM Kit to Evaluate the TPS2490/91 HSPM IC

Procedures similar to the steps of Section 3.2.2 for functional test of the EVM can also be used to evaluate the TPS2490 or TPS2491 controller. Additional details about the EVM features are provided in this section.

Topic	Page
4.1 Test Points	4-2
4.2 Input and Output Capacitors	4-2
4.3 TIMER Capacitors	4-3
4.4 PROG Capacitors	4-3
4.5 GATE Capacitors	4-3
4.6 Evaluation Without the Backplane Board	4-3

4.1 Test Points

The EVM contains numerous test points located throughout the circuit for waveform monitoring. Lists of the EVM main board and backplane board test points and their associated signals are given in Table 4–1 and Table 4–2 respectively.

Table 4–1. +48 V Hot Swap EVM Backplane Board Test Points

Test Point No.	Signal Name	Description
TP1B	GND	Ground
TP2B	48V	48 V supply input
TP3B	GND	Ground
TP4B	48V	48 V supply input

Table 4–2. +48 V Hot Swap EVM Main Board Test Points

Test Point No.	Signal Name	Description
TP1	48V	Voltage input
TP2	GND	Ground
TP3	EN	Device EN pin
TP4	VREF	Device VREF pin
TP5	PROG	Device PROG pin
TP6	TIMER	Device TIMER pin
TP7	GND	Device GND pin
TP8	GND	Ground
TP9	VCC	Device VCC pin
TP10	SENSE	Device SENSE pin
TP11	GATE	Device GATE pin
TP12	OUT	Device OUT pin
TP13	PG	Device PG pin
TP14	GND	Ground
TP15	OUT	Voltage output
TP16	GND	Ground

4.2 Input and Output Capacitors

Two spare bulk capacitor footprints are provided on both the backplane board (C3B and C4B) and the main board (C8 and C9) to increase the input capacitance on the supply end and/or the output capacitance on the load. When adding any of the large aluminum electrolytic capacitors, select capacitors with an appropriate voltage rating, and to observe the polarity marking on the PCB silkscreen. The recommended voltage rating for these capacitors is 100 V.

4.3 TIMER Capacitor

On the EVM main board, a 0.1- μ F ceramic capacitor (C3) is placed on the TIMER pin of the device. Besides, a spare capacitor footprint (C4) is provided to add additional capacitance on TIMER when needed. For example, if capacitors are placed on C8 and/or C9, the 0.1- μ F TIMER capacitor may not be large enough, and it would need to add additional capacitance on TIMER through C4.

4.4 PROG Capacitor

A spare ceramic-capacitor footprint (C2) is provided on the EVM main board for adding capacitance on the PROG pin of the device. When a small capacitor is placed on C2, the initial turnon inrush current slew rate is reduced, but the overall turnon time is longer.

4.5 GATE Capacitor

A spare ceramic capacitor footprint (C5) is provided to add capacitance on the GATE pin of the device. Although the device is designed for power-limiting hotswap control, the TPS2490 or TPS2491 can be used as a dV/dt hot-swap controller by removing resistor R4 and adding a gate capacitor on C5. Increasing the value of C5 increases the output voltage ramp-up time. The recommended capacitance range of C5 is 5 nF to 1 μ F. When using power-limiting control as the EVM is designed for, no capacitor should be placed on C5. The recommended voltage rating for the GATE capacitor is 100 V.

4.6 Evaluation Without the Backplane Board

The EVM main board alone can be used to evaluate all the functions of the TPS2490 or TPS2491 device except the performance in a live hot-swap event. Switch S1 on main board serves almost the same functionality of the switch SW1 on the backplane board. The difference is that the SW1 switches the EN signal of the device between the input voltage V_{IN} and the ground, but the switch S1 only switches the EN signal between 0.033 V_{IN} and ground. When using the EVM main board only, configure as listed below:

- Connect input power supply between jacks J1 and J2.
- Add a 100-V, 100 μ F (or larger) input capacitor between J1 and J2.
- Use switch S1 to turn on (placed in AUTO position) or turn off (placed in MANU position) the device.
- Input supply voltage must be at least 42 V as defined in Table 2–4.



IMPORTANT NOTICE

Texas Instruments Incorporated and its subsidiaries (TI) reserve the right to make corrections, modifications, enhancements, improvements, and other changes to its products and services at any time and to discontinue any product or service without notice. Customers should obtain the latest relevant information before placing orders and should verify that such information is current and complete. All products are sold subject to TI's terms and conditions of sale supplied at the time of order acknowledgment.

TI warrants performance of its hardware products to the specifications applicable at the time of sale in accordance with TI's standard warranty. Testing and other quality control techniques are used to the extent TI deems necessary to support this warranty. Except where mandated by government requirements, testing of all parameters of each product is not necessarily performed.

TI assumes no liability for applications assistance or customer product design. Customers are responsible for their products and applications using TI components. To minimize the risks associated with customer products and applications, customers should provide adequate design and operating safeguards.

TI does not warrant or represent that any license, either express or implied, is granted under any TI patent right, copyright, mask work right, or other TI intellectual property right relating to any combination, machine, or process in which TI products or services are used. Information published by TI regarding third-party products or services does not constitute a license from TI to use such products or services or a warranty or endorsement thereof. Use of such information may require a license from a third party under the patents or other intellectual property of the third party, or a license from TI under the patents or other intellectual property of TI.

Reproduction of information in TI data books or data sheets is permissible only if reproduction is without alteration and is accompanied by all associated warranties, conditions, limitations, and notices. Reproduction of this information with alteration is an unfair and deceptive business practice. TI is not responsible or liable for such altered documentation.

Resale of TI products or services with statements different from or beyond the parameters stated by TI for that product or service voids all express and any implied warranties for the associated TI product or service and is an unfair and deceptive business practice. TI is not responsible or liable for any such statements.

Following are URLs where you can obtain information on other Texas Instruments products & application solutions:

Products		Applications	
Amplifiers	amplifier.ti.com	Audio	www.ti.com/audio
Data Converters	dataconverter.ti.com	Automotive	www.ti.com/automotive
DSP	dsp.ti.com	Broadband	www.ti.com/broadband
Interface	interface.ti.com	Digital Control	www.ti.com/digitalcontrol
Logic	logic.ti.com	Military	www.ti.com/military
Power Mgmt	power.ti.com	Optical Networking	www.ti.com/opticalnetwork
Microcontrollers	microcontroller.ti.com	Security	www.ti.com/security
		Telephony	www.ti.com/telephony

Video & Imaging

www.ti.com/video

Wireless

www.ti.com/wireless

Mailing Address: Texas Instruments
Post Office Box 655303 Dallas, Texas 75265

Copyright © 2003, Texas Instruments Incorporated

EVM IMPORTANT NOTICE

Texas Instruments (TI) provides the enclosed product(s) under the following conditions:

This evaluation kit being sold by TI is intended for use for **ENGINEERING DEVELOPMENT OR EVALUATION PURPOSES ONLY** and is not considered by TI to be fit for commercial use. As such, the goods being provided may not be complete in terms of required design-, marketing-, and/or manufacturing-related protective considerations, including product safety measures typically found in the end product incorporating the goods. As a prototype, this product does not fall within the scope of the European Union directive on electromagnetic compatibility and therefore may not meet the technical requirements of the directive.

Should this evaluation kit not meet the specifications indicated in the EVM User's Guide, the kit may be returned within 30 days from the date of delivery for a full refund. **THE FOREGOING WARRANTY IS THE EXCLUSIVE WARRANTY MADE BY SELLER TO BUYER AND IS IN LIEU OF ALL OTHER WARRANTIES, EXPRESSED, IMPLIED, OR STATUTORY, INCLUDING ANY WARRANTY OF MERCHANTABILITY OR FITNESS FOR ANY PARTICULAR PURPOSE.**

The user assumes all responsibility and liability for proper and safe handling of the goods. Further, the user indemnifies TI from all claims arising from the handling or use of the goods. Please be aware that the products received may not be regulatory compliant or agency certified (FCC, UL, CE, etc.). Due to the open construction of the product, it is the user's responsibility to take any and all appropriate precautions with regard to electrostatic discharge.

EXCEPT TO THE EXTENT OF THE INDEMNITY SET FORTH ABOVE, NEITHER PARTY SHALL BE LIABLE TO THE OTHER FOR ANY INDIRECT, SPECIAL, INCIDENTAL, OR CONSEQUENTIAL DAMAGES.

TI currently deals with a variety of customers for products, and therefore our arrangement with the user **is not exclusive**.

TI assumes **no liability for applications assistance, customer product design, software performance, or infringement of patents or services described herein.**

Please read the EVM User's Guide and, specifically, the EVM Warnings and Restrictions notice in the EVM User's Guide prior to handling the product. This notice contains important safety information about temperatures and voltages. For further safety concerns, please contact the TI application engineer.

Persons handling the product must have electronics training and observe good laboratory practice standards.

No license is granted under any patent right or other intellectual property right of TI covering or relating to any machine, process, or combination in which such TI products or services might be or are used.

Mailing Address:

Texas Instruments
Post Office Box 655303
Dallas, Texas 75265

Copyright © 2003, Texas Instruments Incorporated



EVM WARNINGS AND RESTRICTIONS

It is important to operate this EVM within the input voltage range of 9–80 V and the output voltage range of 9 V and 80 V.

Exceeding the specified input range may cause unexpected operation and/or irreversible damage to the EVM. If there are questions concerning the input range, please contact a TI field representative prior to connecting the input power.

Applying loads outside of the specified output range may result in unintended operation and/or possible permanent damage to the EVM. Please consult the EVM User's Guide prior to connecting any load to the EVM output. If there is uncertainty as to the load specification, please contact a TI field representative.

During normal operation, some circuit components may have case temperatures greater than 85°C. The EVM is designed to operate properly with certain components above 85°C as long as the input and output ranges are maintained. These components include but are not limited to linear regulators, switching transistors, pass transistors, and current sense resistors. These types of devices can be identified using the EVM schematic located in the EVM User's Guide. When placing measurement probes near these devices during operation, please be aware that these devices may be very warm to the touch.

Mailing Address:

Texas Instruments
Post Office Box 655303
Dallas, Texas 75265

Copyright © 2003, Texas Instruments Incorporated

IMPORTANT NOTICE

Texas Instruments Incorporated and its subsidiaries (TI) reserve the right to make corrections, modifications, enhancements, improvements, and other changes to its products and services at any time and to discontinue any product or service without notice. Customers should obtain the latest relevant information before placing orders and should verify that such information is current and complete. All products are sold subject to TI's terms and conditions of sale supplied at the time of order acknowledgment.

TI warrants performance of its hardware products to the specifications applicable at the time of sale in accordance with TI's standard warranty. Testing and other quality control techniques are used to the extent TI deems necessary to support this warranty. Except where mandated by government requirements, testing of all parameters of each product is not necessarily performed.

TI assumes no liability for applications assistance or customer product design. Customers are responsible for their products and applications using TI components. To minimize the risks associated with customer products and applications, customers should provide adequate design and operating safeguards.

TI does not warrant or represent that any license, either express or implied, is granted under any TI patent right, copyright, mask work right, or other TI intellectual property right relating to any combination, machine, or process in which TI products or services are used. Information published by TI regarding third-party products or services does not constitute a license from TI to use such products or services or a warranty or endorsement thereof. Use of such information may require a license from a third party under the patents or other intellectual property of the third party, or a license from TI under the patents or other intellectual property of TI.

Reproduction of TI information in TI data books or data sheets is permissible only if reproduction is without alteration and is accompanied by all associated warranties, conditions, limitations, and notices. Reproduction of this information with alteration is an unfair and deceptive business practice. TI is not responsible or liable for such altered documentation. Information of third parties may be subject to additional restrictions.

Resale of TI products or services with statements different from or beyond the parameters stated by TI for that product or service voids all express and any implied warranties for the associated TI product or service and is an unfair and deceptive business practice. TI is not responsible or liable for any such statements.

TI products are not authorized for use in safety-critical applications (such as life support) where a failure of the TI product would reasonably be expected to cause severe personal injury or death, unless officers of the parties have executed an agreement specifically governing such use. Buyers represent that they have all necessary expertise in the safety and regulatory ramifications of their applications, and acknowledge and agree that they are solely responsible for all legal, regulatory and safety-related requirements concerning their products and any use of TI products in such safety-critical applications, notwithstanding any applications-related information or support that may be provided by TI. Further, Buyers must fully indemnify TI and its representatives against any damages arising out of the use of TI products in such safety-critical applications.

TI products are neither designed nor intended for use in military/aerospace applications or environments unless the TI products are specifically designated by TI as military-grade or "enhanced plastic." Only products designated by TI as military-grade meet military specifications. Buyers acknowledge and agree that any such use of TI products which TI has not designated as military-grade is solely at the Buyer's risk, and that they are solely responsible for compliance with all legal and regulatory requirements in connection with such use.

TI products are neither designed nor intended for use in automotive applications or environments unless the specific TI products are designated by TI as compliant with ISO/TS 16949 requirements. Buyers acknowledge and agree that, if they use any non-designated products in automotive applications, TI will not be responsible for any failure to meet such requirements.

Following are URLs where you can obtain information on other Texas Instruments products and application solutions:

Products		Applications	
Amplifiers	amplifier.ti.com	Audio	www.ti.com/audio
Data Converters	dataconverter.ti.com	Automotive	www.ti.com/automotive
DSP	dsp.ti.com	Broadband	www.ti.com/broadband
Interface	interface.ti.com	Digital Control	www.ti.com/digitalcontrol
Logic	logic.ti.com	Military	www.ti.com/military
Power Mgmt	power.ti.com	Optical Networking	www.ti.com/opticalnetwork
Microcontrollers	microcontroller.ti.com	Security	www.ti.com/security
RFID	www.ti-rfid.com	Telephony	www.ti.com/telephony
Low Power Wireless	www.ti.com/lpw	Video & Imaging	www.ti.com/video
		Wireless	www.ti.com/wireless

Mailing Address: Texas Instruments, Post Office Box 655303, Dallas, Texas 75265
Copyright © 2007, Texas Instruments Incorporated